

# PRODUCT SPECIFICATION

---

- Tentative Specification
- Preliminary Specification
- Approval Specification

**MODELNAME:G080WUM-N81**

**Version:LA01**

<b>Customer: Common</b>	
<b>APPROVED BY</b>	<b>SIGNATURE</b>
<b>Name / Title</b> _____	_____
Note	
_____	
Please return 1 copy for your confirmation with your signature and comments.	

Approved By	Checked By	Prepared By



# CONTENT

No.	ITEM	PAGE
1.	<b>GENERAL INFORMATION</b> (主要特征描述)	4
2.	<b>DIAGRAM FOR LCM</b> (LCM 示意图纸)	5
3.	<b>INTERFACE DESCRIPTION</b> (接口定义描述)	6
4.	<b>ABSOLUTE MAXIMUM RATINGS</b> (极限参数)	7
5.	<b>ELECTRICAL CHARACTERISTICS</b> (模块电气特性)	7
6	<b>BACKLIGHT SPECIFICATION</b> (背光电气特性)	8
7.	<b>TIMING CHARACTERIST</b> (时序特征)	9~12
8.	<b>ELECTRO-OPTICAL CHARACTERISTICS</b> (光电参数)	13~15
9.	<b>RELIABILITY TEST CONDITIONS</b> (可靠性实验条件)	16
10.	<b>INSPECTION STANDARDS</b> (检查标准)	17~19
11.	<b>PACKAGE DRAWING</b> (包装示意图)	19
12.	<b>PRECAUTIONS FOR USING LCD MODULES</b> (使用注意事项)	20~25

## 1. GENERAL INFORMATION (主要特征描述)

### 1.1 features

- 1) Structure: TFT PANNEL+IC+FPC+BL
- 2) IPS Type LCD 1920 (RGB) dot-segment and 1200 dot-common outputs
- 3) 16.7M Color can be selected by software
- 4) White LED back light
- 5) LVDS interface
- 6) Operation Temperature : -30~85°C
- 7) Storage Temperature : -30~85°C
- 8) CTP cover lens : /
- 9) CTP structure : /
- 10) LED life time: /

### 1.2 General specification

Item of	Contents	Unit
Panel Size	8.0	inch
LCD Type	a-si/TRANSMISSIVE	/
Display mode	Normally Black	/
Pixel arrangement	1920(R. G. B)*1200	Dots
Pixel pitch (W*H)	29.9(H)×3×89.7(V)	um
Active Area	172.224(H) ×107.640(V)	Mm
LCM Module area (W*H*T)	119.8*181.7*5.5	Mm
Recommended Viewing Direction	ALL	0' clock
LCM IC	FL5893DA*2	/
CTP IC	/	/
Interface	LVDS-2	/
Luminance for LCM	1000(min)	cd/m2
NTSC	75	%
Weight	TBD	g

## 2. DIAGRAM FOR TP/M(结构示意图)

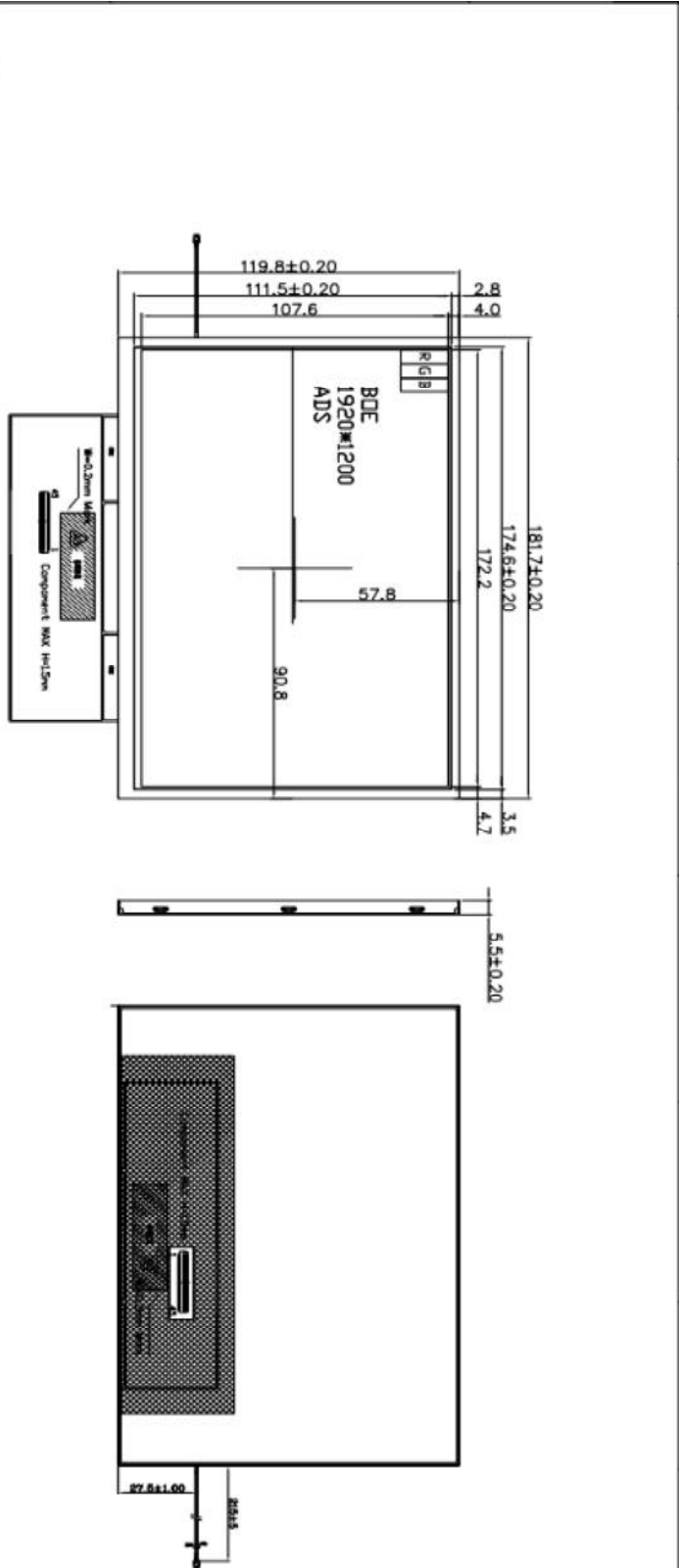

Notes:

1. Unit:mm.
2. draft angle: 1°
3. Do not scale drawing.
4. Modification Mark.
5. General tolerance: ±0.3mm
6. The measured value of luminance and color coordinate bases HCX's BM-7
7. Electrical—Optical Characteristics:

Item (项目)	符号 Symbol	最小值 Min	典型值 Center	最大值 Max	单位 Units	NOTE
Backlight Voltage 背光电压	Vf	15.8	18	19.2	V	
Backlight Current 背光电流	I <sub>r</sub>	---	360	---	mA	T=25°C 所有测试 误差为5%
Colour色坐标	X	0.26	---	0.36	---	
	Y	0.27	---	0.37	---	
Luminance 亮度		900	1000	---	cd/m <sup>2</sup>	恒定电流 测试
Uniformity 均匀性	Δ	75	80	---	%	
Customer: 客户						
REV	DESCRIPTION (修改内容)					
DATE						
REVISER						

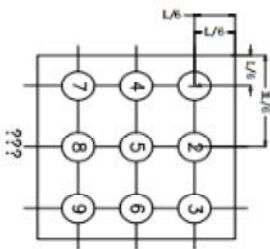
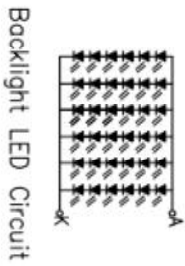

### 3. INTERFACE DESCRIPTION(接口定义描述)

LCM PIN	SYMBLE	Description
1	VLED-	Power for LED backlighr (Cathode)
2	VLED-	Power for LED backlighr (Cathode)
3	VLED+	Power for LED backlighr (Anode)
4	VLED+	Power for LED backlighr (Anode)
5	NC	No connection
6	GND	ground
7	ELV3P	LVDS differential data input Positive
8	ELV3N	LVDS differential data input Negative
9	GND	ground
10	ELV2P	LVDS differential data input Positive
11	ELV2N	LVDS differential data input Negative
12	GND	ground
13	ELVCLKP	LVDS differential data input Positive
14	ELVCLKN	LVDS differential data input Negative
15	GND	ground
16	ELV1P	LVDS differential data input Positive
17	ELV1N	LVDS differential data input Negative
18	GND	ground
19	ELVOP	LVDS differential data input Positive
20	ELVON	LVDS differential data input Negative
21	GND	ground
22	OLV3P	LVDS differential data input Positive
23	OLV3N	LVDS differential data input Negative
24	GND	ground
25	OLV2P	LVDS differential data input Positive
26	OLV2N	LVDS differential data input Negative
27	GND	ground
28	OLVCLKP	LVDS differential data input Positive
29	OLVCLKN	LVDS differential data input Negative
30	GND	ground
31	OLV1P	LVDS differential data input Positive
32	OLV1N	LVDS differential data input Negative
33	GND	ground
34	OLVOP	LVDS differential data input Positive
35	OLVON	LVDS differential data input Negative
36	GND	ground
37	I2C _SDA	data input/output for I2C(please let these pins open.)
38	I2C _SCL	Clock signal for I2C(please let these pins open.)

39	VDD_OTP	Power supply for OTP circuit(please let these pins open.)
40	EEPEN	Only test Pin( please let these pins open.)
41	VDDIN	Power supply
42	VDDIN	Power supply
43	VDDIN	Power supply
44	VDDIN	Power supply
45	VDDIN	Power supply

#### 4. ABSOLUTE MAXIMUM RATINGS(极限参数)

Item	Symbol	Min	TYP	Max	Unit	NOTE
Operating temperature	Top	-30	-	85	°C	At 25±5°C
Storage temperature	Tst	-30	-	85	°C	
Humidity	RH	-	90%(Max60°C)	-	RH	
Power Voltage	VDD	0.3	-	3.6	V	
	IOVCC		-	3.6		

Notel: If users use the product out off the environmental operation range (temperature and humidity,it will have visual quality concerns.

注 1: 如果用户使用的产品超出了环境操作范围 (温度和湿度), 则将存在视觉质量问题。

**5.ELECTRICAL CHARACTERISTICS(模块电气特性)**

Parameter of DC characteristics	Symbol	Min	TYP	Max	Unit	NOTE
Supply Voltage	TP-VDD	2.7	2.8	3.6	V	
	IOVCC/IIC	1.7	1.8	1.9	V	
	AVDD	-	-	-	V	
	AVEE	-	-	-	V	
	VGL	-	-	-	V	
VCOM	VCOM	-	-	-	V	
Input Current	I <sub>dd</sub>	-	370	400	MA	

**6.BACKLIGHT SPECIFICATION(背光电气特性)**

Item of backlight characteristics	Symbol	Min	TYP	Max	Unit	NOTE
Forward Voltage	V <sub>f</sub>	16.8	18	19.2	V	
	I <sub>f</sub>	-	360	-	MA	
BL Luminance	LV	900	1000	1200	cd/m <sup>2</sup>	
Backlight uniformity	-	-	80%	-	No less than 80% 均匀性	
Number of LED	-	(6串6并) 36			Pcs	

## 7.TIMING CHARACTERIST(时序特征)

### 7.1 Timings for DSI video mode

#### 7.1.2 Vertical Timing

Parallel RGB

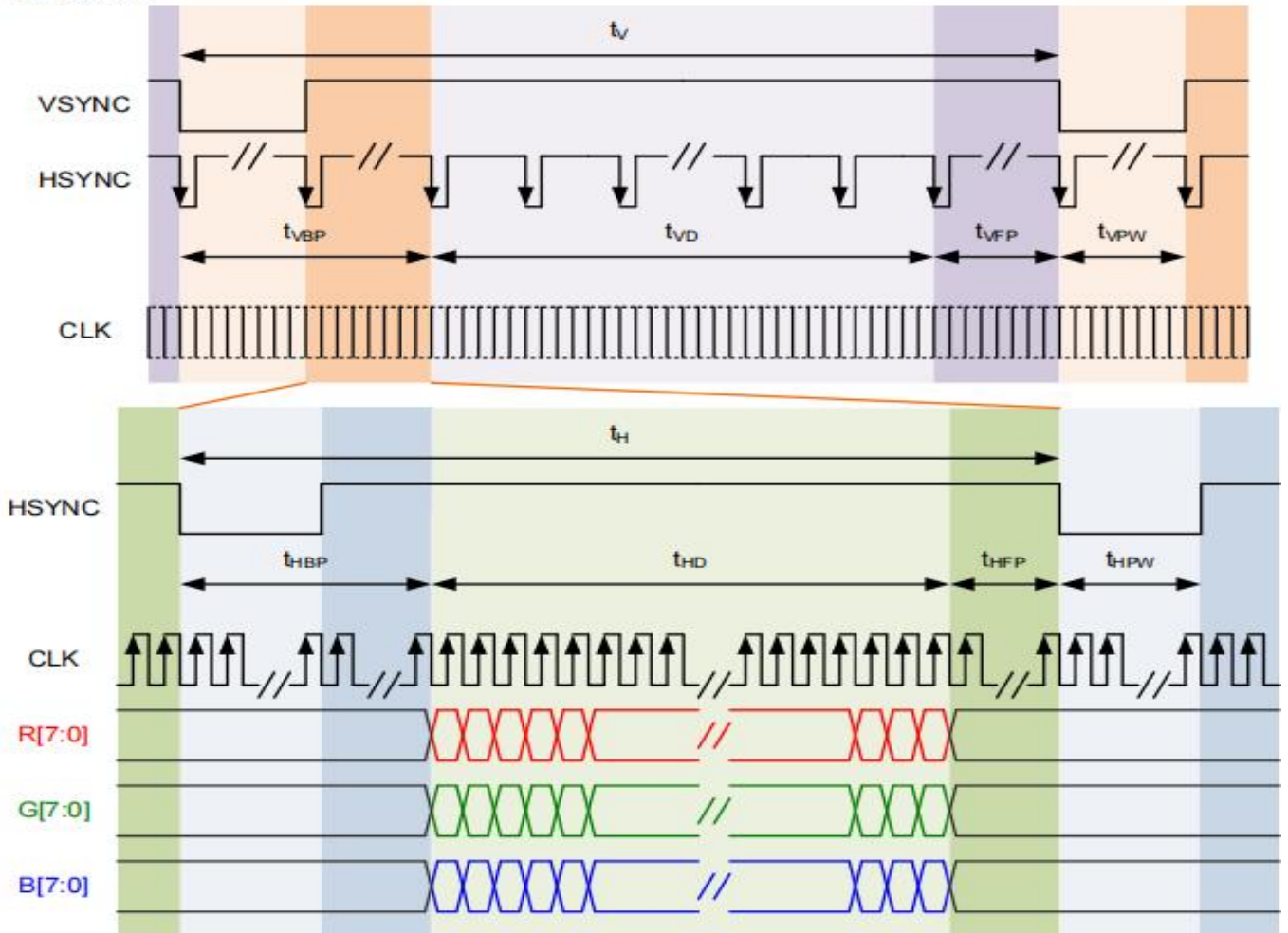

1920 x 1200 (Only 2-Port)

Parameter	Symbol	Value			Unit	Note
		Min.	Typ.	Max.		
CLK frequency	tCLK	66	74.4	80	Mhz	
Horizontal blanking time	tHBT	40	40	99	tCLK	tHBP + tHFP
Horizontal back porch	tHBP	20	20	253	tCLK	Include tHPW
Horizontal display area	tHD		960		tCLK	
Horizontal front porch	tHFP	20	20	255	tCLK	
Horizontal period	tH	1000	1000	1059	tCLK	
Horizontal pulse width	tHPW	2	2	2	tCLK	
Vertical blanking time	tVBT	20	40	100	tH	tVBP + tVFP
Vertical back porch	tVBP	10	20	253	tH	Include tVPW
Vertical display area	tVD		1200		tH	
Vertical front porch	tVFP	10	20	255	tH	
Vertical period	tV	1200	1240	1300	tH	
Vertical pulse width	tVPW	2	2	2	tH	
Frame rate	FR	60	60	60	Hz	

### 7. 1. 3 POWER MODE TIMINGS

#### 5 Power Mode

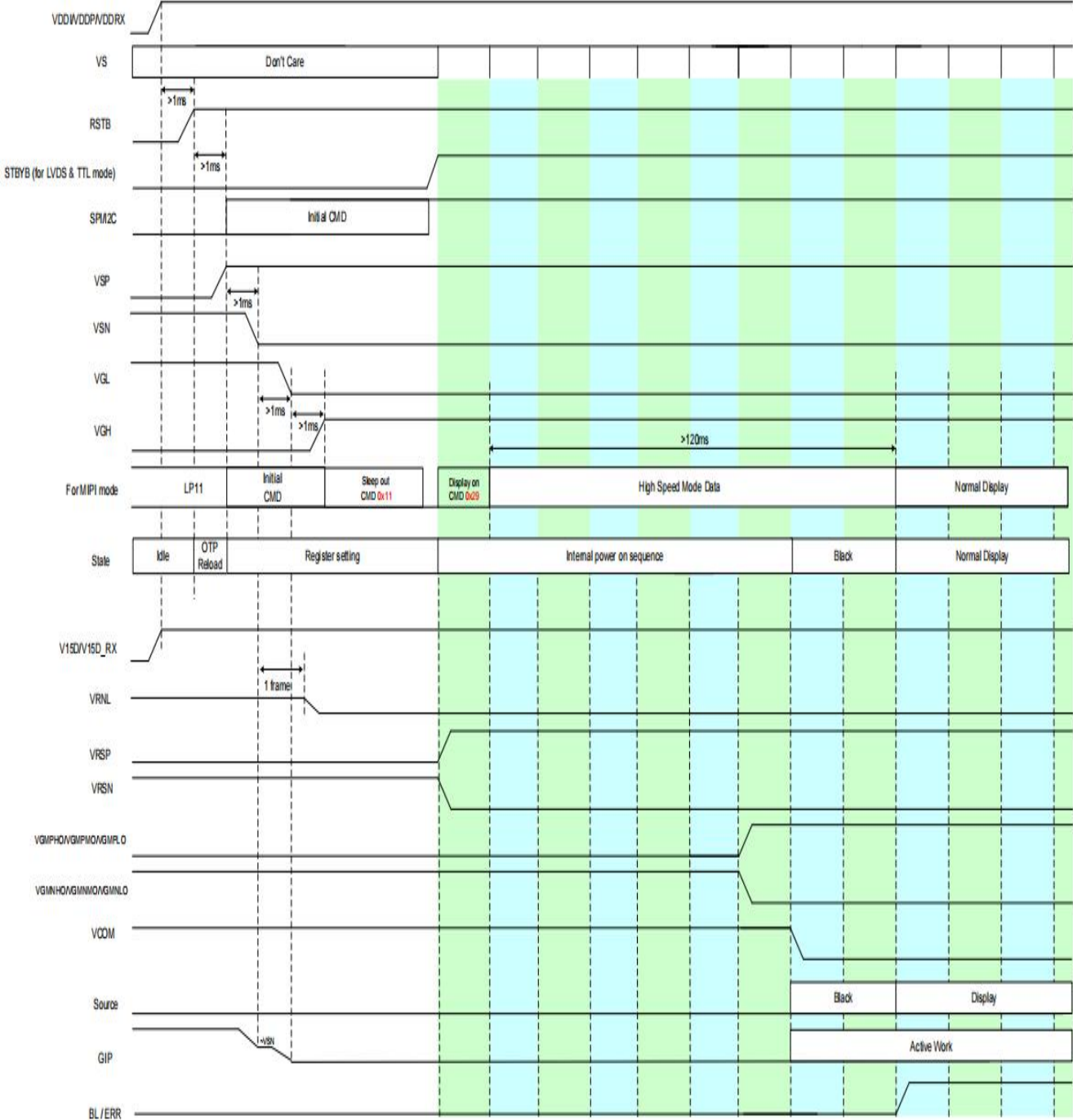

## 8. ELECTRO-OPTICAL CHARACTERISTICS (光电参数)

Parameter		Symbol	Condition	Min.	Typ.	Max.	Unit	Remark
Viewing Angle Range	Horizontal	$\Theta_3$	CR > 10	80	85	-	Deg.	Note 6.1
		$\Theta_9$		80	85	-	Deg.	
	Vertical	$\Theta_{12}$		80	85	-	Deg.	
		$\Theta_6$		80	85	-	Deg.	
Contrast Ratio		CR	$\Theta = 0^\circ$	1000	1200	-		HC+APF
Cell Transmittance		Tr		3.8	4.5	-	%	Note 6.2/6.3
Chroma@CIE1931		Rx	$\Theta = 0^\circ$	0.654	0.674	0.694		@C Light Note 6.4
		Ry		0.302	0.322	0.342		
		Gx		0.249	0.269	0.289		
		Gy		0.582	0.602	0.622		
		Bx		0.113	0.133	0.153		
		By		0.095	0.115	0.135		
		Wx		0.276	0.296	0.316		
		Wy		0.318	0.338	0.358		
Color Gamut			$\Theta = 0^\circ$	70	75	-	%	
Response Time		Tr+Tf	Ta= 25°C $\Theta = 0^\circ$	-	30	35	ms	Note 6.5

Note1 Definition of Contrast Ratio (CR):

$$\text{Contrast ratio (CR)} = \frac{\text{Luminance measured when LCD on the "White" state}}{\text{Luminance measured when LCD on the "Black" state}}$$

Note2: Definition of Luminance Uniformity: Active area is divided into 9 measuring areas (Shown in below), every measuring point is placed at the center of each measuring area.

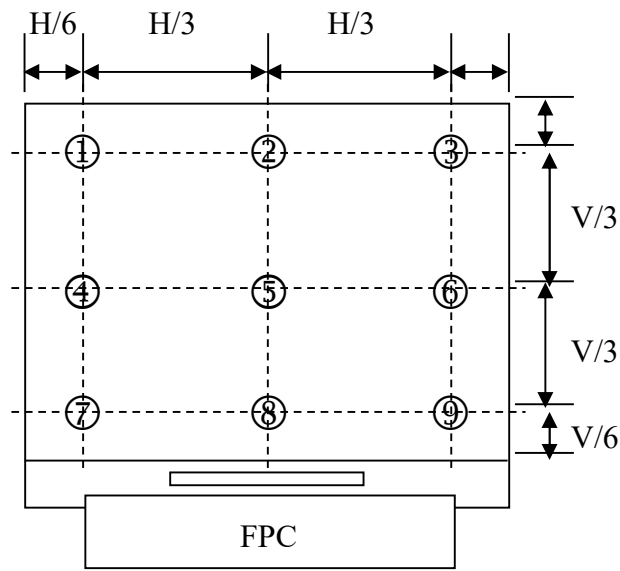

The spot locations for luminance measurement

$$\text{Luminance Uniformity} = \frac{H/6 \cdot B_{\min}}{V/6 \cdot B_{\max}} \times 100\%$$

$B_{\max}$ : The measured maximum luminance of all measurement position.

$B_{\min}$ : The measured minimum luminance of all measurement position.

Note 3: Definition of Response time: Sum of  $T_r$  and  $T_f$

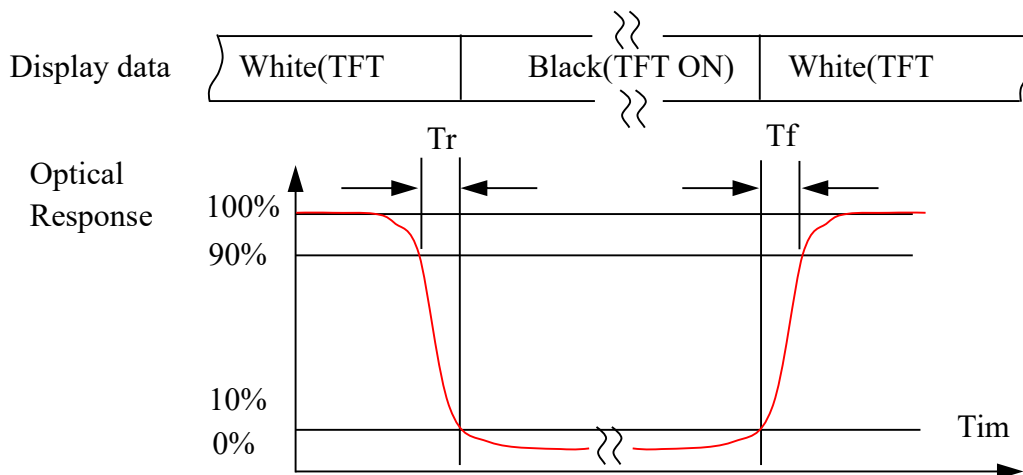

Note4.Definition of Viewing Angle: The viewing angle range that the  $CR \geq 1$

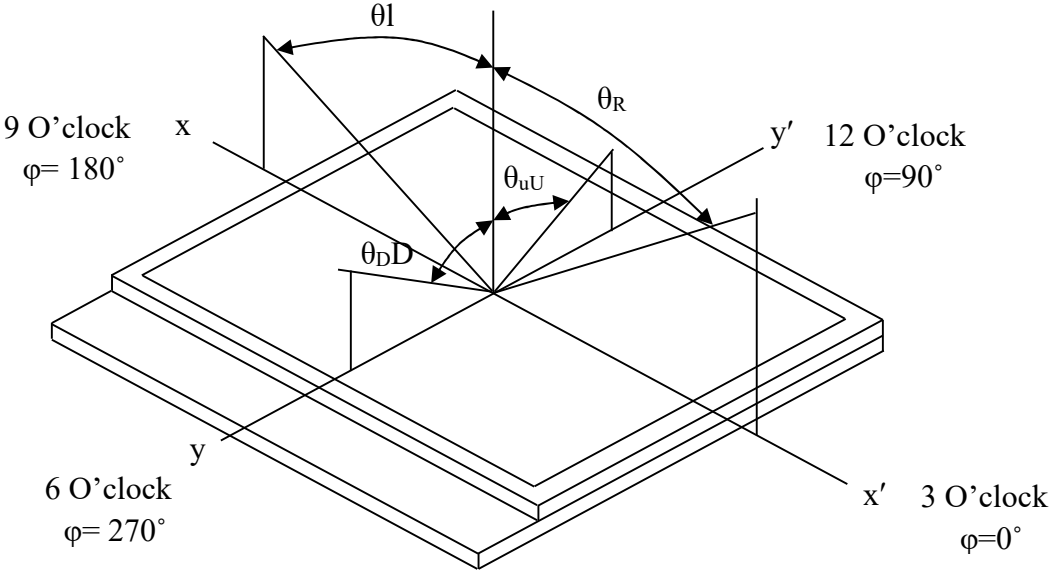

Note 5: Definition of Color Chromaticity (CIE 1931)  
Color coordinate of white & red, green, blue at center point.

## 9. RELIABILITY TEST CONDITIONS(可靠性实验条件)

No	Test Item	Test Condition	STANDARD
1	High Temperature Storage	+85°C / 2 4 0 Hours	1. Functional test is OK. Missing Segment, short, unclear segment, on-display, display abnormally and liquid crystal leak are un-allowed. 2. No low temperature bubbles, end seal loose and fall, frame rainbow.
2	Low Temperature Storage	-30°C / 2 4 0 Hours	
3	High Temperature Operating	+85°C / 2 4 0 Hours	
4	Low Temperature Operating	-30°C / 2 4 0 Hours	
5	Thermal and cold shock	0°C↔+60°C x 10cycles (30min) (5min) (30min)	
6	Operate at High Temperature and Humidity	60°C x 90%RH / 240H	
7	Vibration Test	Frequency: 10Hz~55Hz~10Hz Amplitude:1.5mm, 2 hours for each direction of X, Y, Z	1. Function test is OK. 2. No glass crack, chipped glass, end seal loose and fall, epoxy frame crack and so on. 3. No structure loose and fall.
8	Dropping test	Drop to the ground from 1m height, 1 corner, 3 edges, 6 surfaces.	
9	ESD test	Contact: ±6KV Air: ±10KV 150PF/330Ω,5Points/pa nel,5times	The test results shall be subject to the whole machine test.

### NOTE:

1. The reliability items will be fully performed in new sample qualification,
2. The reliability status will be tested as monitor during mass production. Individual reliability test shall be performed by lot , Moreover, the individual reliability item shall be decided according to reliability plan.
3. All samples are inspected after keeping in the room with normal temperature and humidity for 2 hours or above.
4. Vibration test: It is not necessary to test for those products without assembly frame , backlight , PCB and so on.
5. Dropping test : It is necessary for affirming new package.
6. For the high temperature and high humidity test, pure water of over 10 MΩ.cm should be used.
7. Each test item applies for test LCM only once .Then tested LCM cannot be used again in any other test item.
8. The quantity of LCM examination for each test item is 5pcs to 10pcs.

## 10. INSPECTION STANDARDS(检查标准)

### 10.1 AQL Sampling inspection standard

使用 GB/T 2828-2003 一般 II 水平, 采用正常检查一次抽样方式; 具体抽检方式参照《成品检验管理程序》、《抽样管理规范》

缺陷区分	AQL 允收水准
严重缺陷	0 收 1 退
重缺	0.4
轻缺	1.0

### 10.2 Inspect the condition

10.2.1 在 20—40W 日光灯的照明条件下, 样品离检查者眼睛约 30cm 处进行检查。检验方向以垂直线前后左右 45° (以时钟 3 点、6 点、9 点、12 点)

10.2.2 检验者视力需达到标准视力 1.0 以上。

10.2.3 检验者需戴静电手环、两手八个手指套。

10.2.4 外观检验者以目视检查或以菲林对比卡比对。

10.2.5 电性测试使用电测测架, 主板, 电源线及单片机。

10.2.6 若标准与规格书不符时, 以产品发行之规格书特殊检验规格、工程变更为准

10.2.7 辉色度检测请参照样品, 检测方法依照辉色度检验标准。

10.2.8 电测检验环境: 照度为 200LUX 以下, 外观检验环境: 照度为 600LUX-1000LUX, 检验时间: 1 秒-3 秒。

10.2.9 检验工具: 电测测架, 主板, 电源线及单片机, 菲林对比卡, 游标卡尺, 放大镜, 实体显微镜(必要时)等等。

### 10.3 Judgment criterion

小尺寸点、线判定标准: (6.2 寸以内)

1	点状缺陷 (磨伤、异物、针孔、凹痕、缺膜、气泡、白点、彩点、脏点)		判定 (A /B/C 区)	$D \leq 0.10$ , 忽略不计, 但密集型不允许	MI	OK
				$0.1 < D \leq 0.15, ds \geq 10$		$N \leq 2$
				$0.15 < D \leq 0.2, ds \geq 10$		$N \leq 1$
				LCD 亮点: $0.15 < D$		$N \leq 1$
				$D > 0.2$		NG
		判定 (D 区)	同背面丝印油墨区杂质判定标准			
		注: 1) D 区的点状缺陷需在不影响 CTP 功能、客户组装及整机的外观的情况下, 判定 OK			MI	
2	线状缺陷 (磨伤、		判定 (A /B/C 区)	$W \leq 0.03mm, L \leq 3mm, ds \geq 10$	MI	$N \leq 2$
				$0.03mm < W \leq 0.05mm, L$		$N \leq 1$

	无感划伤、毛屑、纤维等)			$\leq 3mm, ds \geq 10$		
				$W > 0.05mm$ 或 $L > 3mm$		

中尺寸点、线判定标准：（6.2~8寸以内）

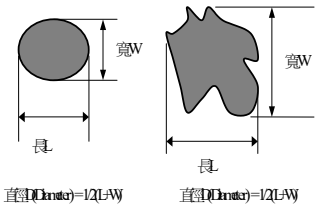
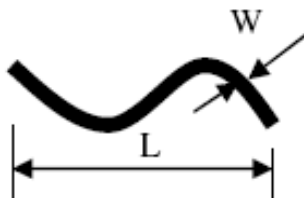
1	点状缺陷 (磨伤、异物、针孔、凹痕、缺膜、气泡、白点、彩点、脏点)		判定(A/B/C区)	$D \leq 0.10$ , 忽略不计, 但密集型不允许	MI	OK
				$0.15 < D \leq 0.25, ds \geq 10$		$N \leq 2$
				$0.25 < D \leq 3, ds \geq 10$		$N \leq 1$
				LCD亮点: $0.2 < D$		$N \leq 1$
				$D > 0.3$		NG
			判定(D区)	同背面丝印油墨区杂质判定标准		
			注: 1) D区的点状缺陷需在不影响CTP功能、客户组装及整机的外观的情况下, 判定OK		MI	
2	线状缺陷 (磨伤、无感划伤、毛屑、纤维等)		判定(A/B/C区)	$W \leq 0.03mm, L \leq 3mm, ds \geq 10$	MI	$N \leq 2$
				$0.03mm < W \leq 0.05mm, L \leq 3mm, ds \geq 10$		$N \leq 1$
				$W > 0.05mm$ 或 $L > 3mm$		NG

大尺寸点、线判定标准：（8.1~13.3寸以内）

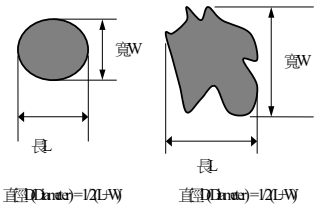
1	点状缺陷 (磨伤、异物、针孔、凹痕、缺膜、气泡、白点、彩点、脏点)		判定(A/B/C区)	$D \leq 0.1$ , 忽略不计, 但密集型不允许	MI	OK
				$0.15 < D \leq 0.3, ds \geq 10$		$N \leq 2$
				$0.3 < D \leq 0.35, ds \geq 10$		$N \leq 1$
				LCD亮点: $0.25 < D$		$N \leq 1$
				$D > 0.35$		NG
			判定(D区)	同背面丝印油墨区杂质判定标准		
			注: 1) D区的点状缺陷需在不影响CTP功能、客户组装及整机的外观的情况下, 判定OK		MI	

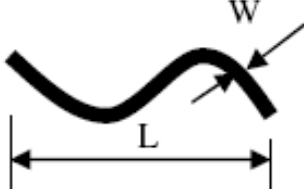
2	线状缺陷 (磨伤、 无感划 伤、毛屑、 纤维等)		判定 (A /B/C 区)	$W \leq 0.05mm, L \leq 5mm, ds \geq 10$	MI	$N \leq 2$
				$0.05mm < W \leq 0.07mm, L \leq 5mm, ds \geq 10$		$N \leq 1$
				$W > 0.07mm$ 或 $L > 5mm$		NG

### 11. PACKAGE DRAWING (包装示意图)

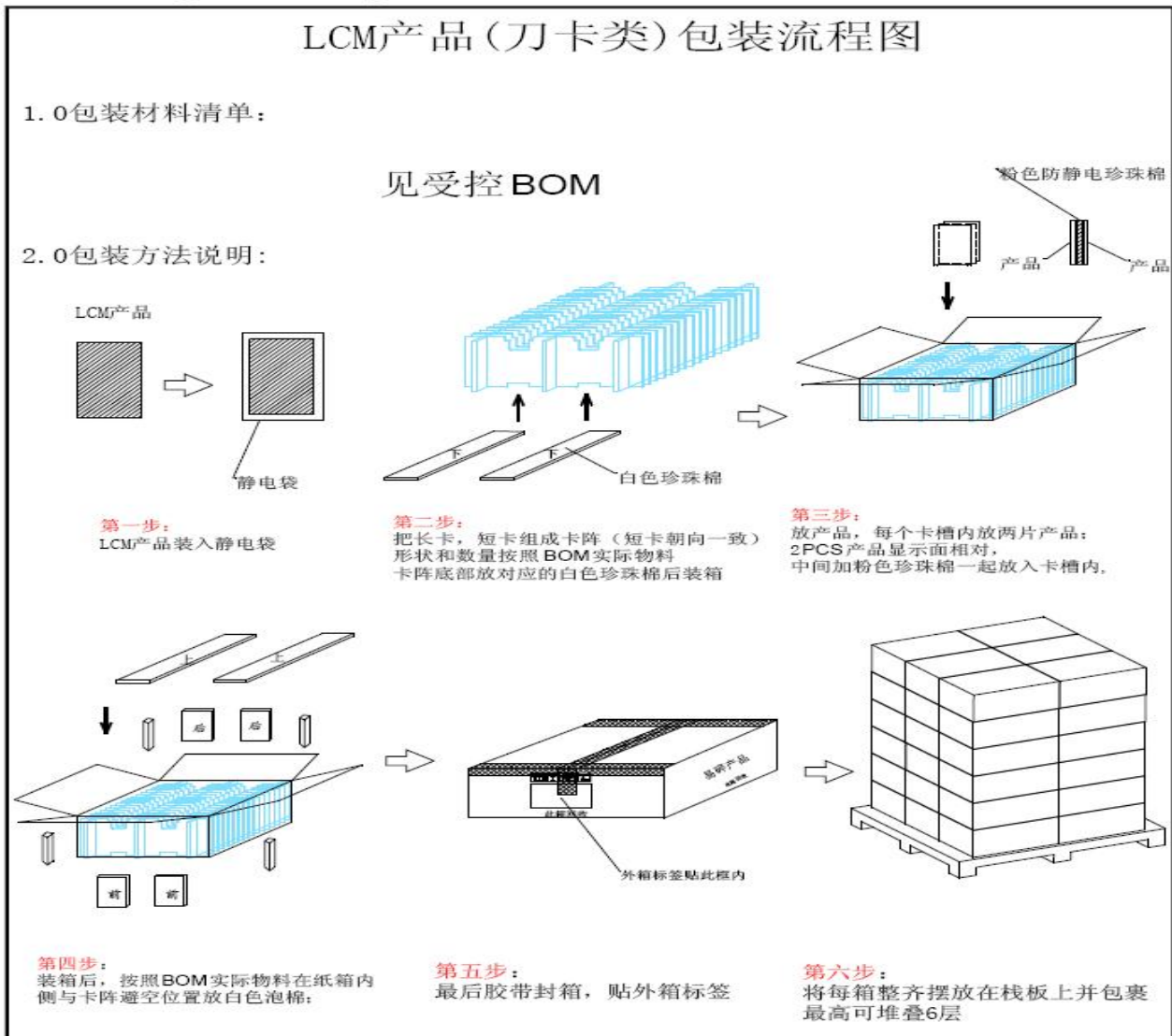

## 12、 PRECAUTIONS FOR USING LCD MODULES(使用注意事项)

### 12.1 Using LCD Modules 使用

12.1.1 As glass is fragile, It tends to become or chipped during handling especially on the edges. Please avoid dropping or jarring. Do not subject it to a mechanical shock by dropping it or impact. (由于玻璃是脆的，使用过程请特别注意边缘区，防止跌落或振动，不能机械碰撞)。

12.1.2 Do not apply excessive force to the display surface or the adjoining areas since this may cause the color tone to vary. Do not touch the display with bare hands. This will stain the display area and degraded insulation between terminals(some cosmetics are determined to the polarizer) (请勿施加过大的压力于显示屏或连接部位，否则会引起色调变化。不要裸手接触显示屏，这将弄脏显示区和降低端子之间的绝缘能力。一些外观问题是由偏光片决定的)。

12.1.4 The polarizer covering the display surface of the LCD module is soft and easily scratched. Handle this polarizer carefully. Do not touch, push or rub the exposed polarizers with anything harder than an HB pencil lead (glass, tweezers, etc.). Do not put or attach anything on the display area to avoid leaving marks on it. Condensation on the surface and contact with terminals due to cold will damage, stain or dirty the polarizer. After products are tested at low temperature they must be warmed up in a

container before coming in to contact with room temperature air. (覆盖液晶显示模块显示平面的偏光片 是软性且易被擦伤, 请小心轻拿。请勿用任何硬度大于 HB 铅笔芯的物品 (玻璃, 镊子等) 接触、撞 压或摩擦裸露偏光片。不要放置或粘附物体在显示区域上以免留下痕迹。冷凝在表面和端子将会损坏 或弄脏偏光片。产品在低温下测试之后, 与室温空气接触之前必须在容器内升温)

12.1.5 If the display surface becomes contaminated, breathe on the surface and gently wipe it with a soft dry cloth. If it is heavily contaminated, moisten cloth with one of the following solvents: Isopropyl alcohol; Ethyl alcohol . Do not scrub hard to avoid damaging the display surface (如果显示平面受污, 可对平面吹热气且轻轻地用软性干布擦除。如果受污严重, 用 含下列一种溶剂的湿布擦除: 甘油, 酒精 。请勿用力擦拭以免损坏显示平面。)

12.1.6 Solvents other than those above-mentioned may damage the polarizer. Especially, do not use the following: Water, Ketone, Aromatic solvents. Wipe off saliva or water drops immediately, contact with water over a long period of time may cause deformation or color fading. Avoid contact with oil and fats. (除以上提到的溶剂外, 其他溶剂可能会损坏偏光片, 特别要避免使用以下溶剂: 水, 丙酮, 芳烃溶剂。立即擦掉唾液或水滴, 长时间与水接触会引起变形或褪色。避免接触油和油脂)

---

12.1.7 Do not attempt to disassemble or process the LCD module. (请勿拆卸液晶显示模块)

12.1.8 Electro-Static Discharge Control, Since this module uses a CMOS LSI, the same careful attention should be paid to electrostatic discharge as for an ordinary CMOS IC. To prevent destruction of the elements by static electricity, be careful to maintain an optimum work environment. (由于液晶显示模块使用 CMOS 集成, 要特别注意静电放电问题。对 CMOS 器件, 要特别注意静电。为防止静电损坏, 注意保持合宜的工作环境)

12.1.9 Input logic voltage before apply analog high voltage such as LCD driving voltage when power on. Remove analog high voltage before logic voltage when power off the module. Input each signal after the positive/negative voltage becomes stable. (开机时, 先让逻辑电压, 再接通模拟高压, 如显示屏驱动电压。关机时, 先断开模拟高压, 再关逻辑电压。正负电源都稳定后再送控制信号。)

12.1.10 In the use of connector products, the operating process of attention to turn off the power before pull off and insert action. To avoid damage to the module (在使用连接器的产品时, 插接过程注意先关闭电源再进行拔插动作, 避免损坏模块)

**12.1.11 When use LENS ,you must be do the following things** (当使用假纯平 TP 结构时，注意须按以下方法处理：LENS 的双面胶避开 RTP 的 FPC 热压位，或在热压位上加贴保护膜，避免 LENS 双面胶拉动 FPC 造成损伤而无触摸)

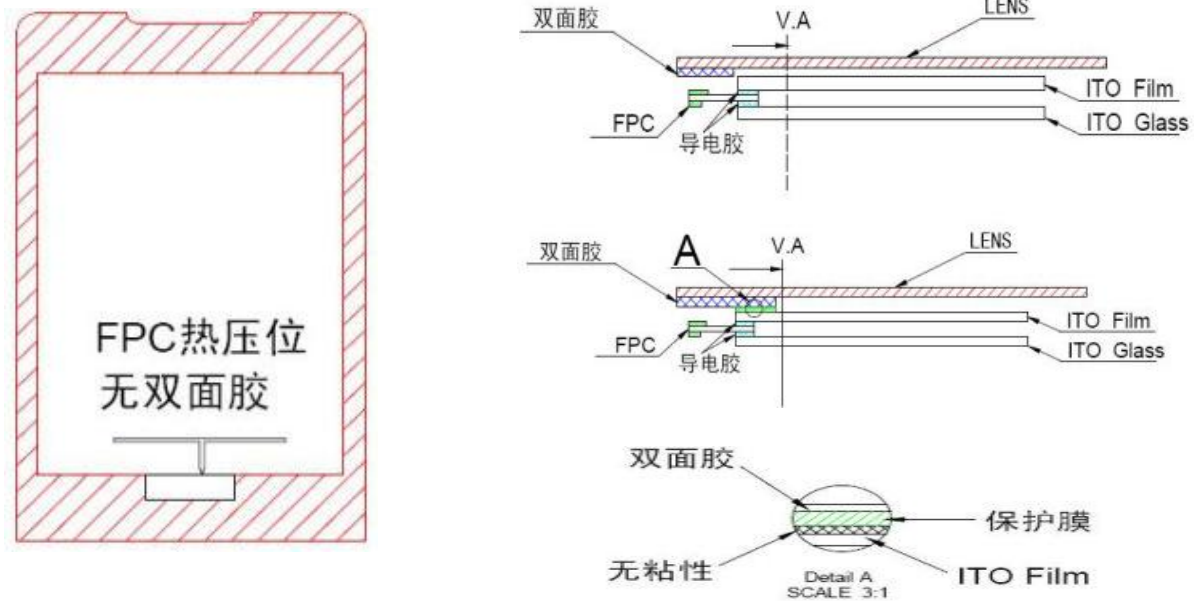

**12.1.12 Precaution for assemble the module with BTB connector: Please note the position of the male and female connector position, don't assemble or assemble like the method which the following picture shows**

(用板对板连接器安装液晶显示模块注意事项： 请注意连接器的公母及连接位置，请勿出现下图 所示的连接方式。)

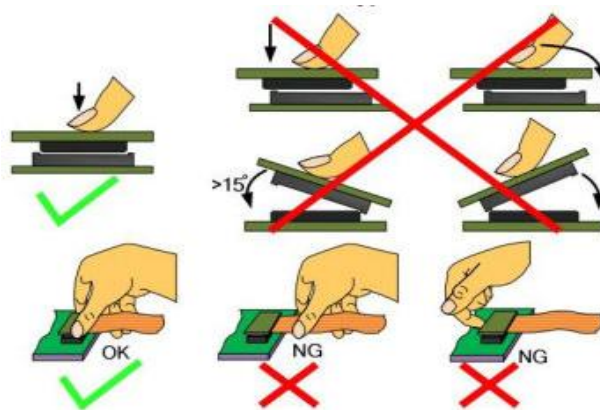

## 12.2 Storage Modules 储存

11.2.1 Store them in a dark place. Do not expose to sunlight or fluorescent light, keep the temperature between 0°C and 35°C, and keep the relative humidity between 40%RH and 60%RH. (避光保存, 避免直接暴露在太阳光或黄光灯下, 保持温度在 0~35 摄氏度之间, 保持相对湿度在 40%RH 和 60%RH 之间。)

12.2.2 The polarizer surface should not come in contact with any other objects (We advise you to store them in the anti-static electricity container in which they were shipped). (偏光片 表面避免接触其他物质, 建议存放在货运防静电包装中)

## 11.3 Soldering

12.3.1 Iron head temperature (铬铁头实际温度) : 350±10°C, Soldering time (焊接时间) : <3-4S.

Soldering don't repeat above 3 times (焊接次数勿超过 3 次)

12.3.2 If soldering flux is used, be sure to remove any remaining flux after finishing to soldering operation (This does not apply in the of a non-halogen type of flux). It is recommended that you protect the LCD surface case with a cover during soldering to prevent any damage due to flux spatters. (如果使用助焊剂, 完成焊接后一定要清除剩余的助焊剂 (除非卤化物助焊剂)。建议焊接时用盖子保护显示屏面以避免因焊剂油溅出造成的任何损坏。)

12.3.3 The gap between the backlight bottom and the shell material shall be 0.3mm min. if the shell material is all plastic, the gap shall be 0.4mm min(背光底部与壳料间隙 **0.3mm min**，如果壳料为全塑胶，间隙需保证 **0.4mm min** )

12.3.4 The back backlight area corresponding to the LCM visual area is recommended to be free of adhesion and resistance of auxiliary materials and foreign matters, so as to avoid poor display caused by top injury of backlight film material;(建议与 LCM 可视区域相对应的背面背光区域不存在辅助材料和异物的粘附和阻力，以避免背光膜材料顶部损伤导致显示不良；)

12.3.5 Due to the characteristics of LCD, the screen cannot be displayed in fixed mode (static mode) for a long time, resulting in residual shadows; If the screen has multiple display modes (static and dynamic), add a screen saver (由于 LCD 的特性，屏幕长时间不能在固定模式（静态模式）下显示，导致残留阴影；如果屏幕有多种显示模式（静态和动态），请添加屏幕保护程序)