

- Tentative Specification
- Preliminary Specification
- Approval Specification

MODEL NAME: G104XL20-S01

Version: C2

Customer: Common	
APPROVED BY	SIGNATURE
Name / Title _____	_____
Note	

Please return 1 copy for your confirmation with your signature and comments.	

Approved By	Checked By	Prepared By

Contents

No.	Items	Page
1.0	General Description	4
2.0	Absolute Maximum Ratings	6
3.0	Input Specifications	7
4.0	Electrical Specification	11
5.0	Timing Specification	12
6.0	Back-Light-Unit	16
7.0	Optical Specifications	17
8.0	Reliability Test	22
9.0	Definition Of Labels	23

1.0 GENERAL DESCRIPTION

1.1 Introduction

G104XL20-S01 is a color active matrix TFT LCD module using amorphous silicon TFT's (Thin Film Transistors) as an active switching devices. This module has a 10.4 inch diagonally measured active area with SVGA resolutions (800 horizontal by 600 vertical pixel array). Each pixel is divided into RED, GREEN, BLUE dots which are arranged in vertical stripe and this module can display 16.7M colors.

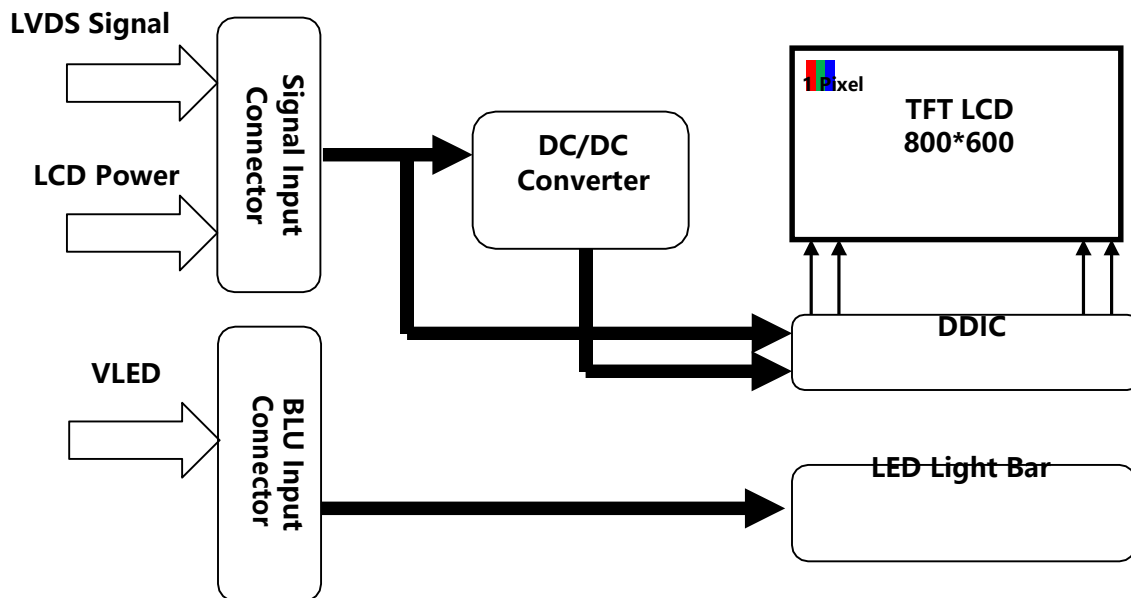

1.2 Features

- 0.5T Glass (Single)
- Reverse Type
- 8bit/6bit LVDS data input selection
- Frame Frequency: 60hz
- High luminance and contrast ratio, low reflection and wide viewing angle
- RoHS compliant

1.3 Application

- Medical & Industrial application

1.4 General Specification

The followings are general specifications at the G104SL-S01

<Table 1. LCD Module Specifications>

Parameter	Specification	Unit	Remarks
Active Area	211.2x158.4	mm	
Number Of Pixels	800*600	pixels	
Pixel Pitch	264x264	μm	
Pixel Arrangement	Pixels RGB stripe arrangement		
Display Mode	TN, Normally White		
Display Colors	16.7M	colors	
Surface Treatment	AG25		
Contrast Ratio	typ 800:1		
Viewing Angle(CR>10)	typ 80/80/65/75	deg.	L/R/U/D
Response Time	typ 30, max 35	ms	
Color Gamut	55%		
Brightness	min 300, typ 350	cd/m2	
Brightness Uniformity	min 70%, typ 80%		9point
Power Consumption	LCD 0.495W Typ. BLU 1.85W Typ.	watt	
Outline Dimension	236.0(H)×176.9(V) ×5.6(Body)	mm	
Weight	TBD		
Display Orientation	Landscape Only		

2.0 TEMPERATURE

Operating Temperature	T_{OP}	-20	+70	°C	Note 1
Storage Temperature	T_{ST}	-30	+80	°C	

Note : 1) Temperature and relative humidity range are shown in the figure below.
 Wet bulb temperature should be 39 °C max. and no condensation of water.

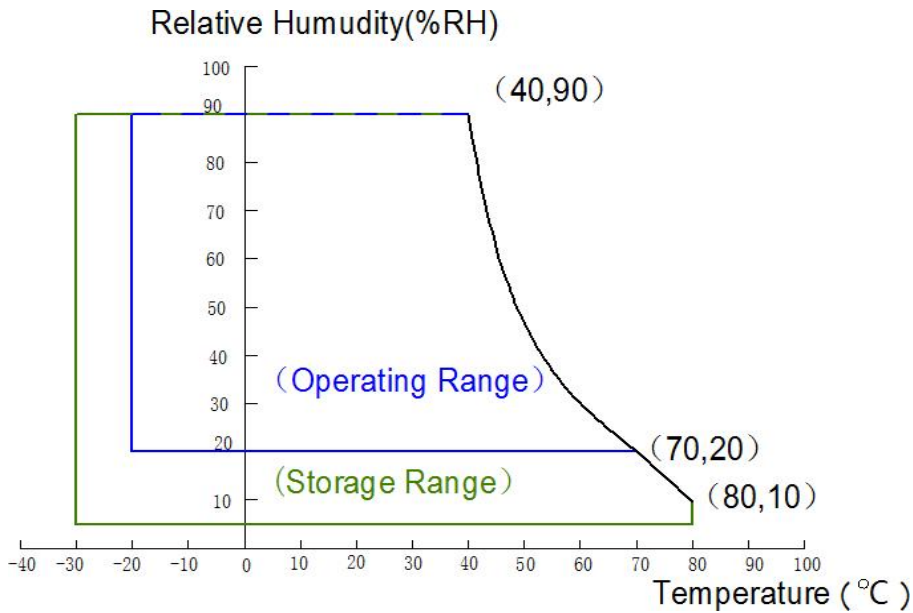

3.0 INPUT TERMINAL PIN ASSIGNMENT

This LCD employs two interface connections, a 20 pin connector is used for the LCD module electronics interface and a 2 pin connector is used for the backlight system.

3.1 Pin assignment for LCD module

Connector : MSB24013P20 _HA(STM) or equivalent

< Table5. Pin Assignment for LCD Module Connector >

Pin No.	Symbol	Description	I/O
1	VCC	Logic Power 3.3V(Panel logic)	P
2	VCC	Logic Power 3.3V(Panel logic)	P
3	NC	Reserved for VDD_MTP	-
4	SEL	VCC:8Bit,GND:6Bit	-
5	RIN0-	LVDS receiver negative signal channel 0	I
6	RIN0+	LVDS receiver positive signal channel 0	I
7	GND	Ground	-
8	RIN1-	LVDS receiver negative signal channel 1	I
9	RIN1+	LVDS receiver positive signal channel 1	I
10	GND	Ground	-
11	RIN2-	LVDS receiver negative signal channel 2	I
12	RIN2+	LVDS receiver positive signal channel 2	I
13	GND	Ground	-
14	CLKIN-	LVDS receiver negative signal clock	I
15	CLKIN+	LVDS receiver positive signal clock	I
16	GND	Ground	-
17	RIN3-	LVDS receiver negative signal channel 3 (NC for 6bit LVDS input)	I
18	RIN3+	LVDS receiver positive signal channel 3 (NC for 6bit LVDS input)	I
19	NC	Reserved for I2C_SDA	-
20	NC	Reserved for I2C_SCL	-

3.2 Pin assignment for LED Bar

Connector : JST BHSR-02VS-1 or equivalent

< Table6. Pin assignment for LED Bar >

Pin No	Symbol	Description	Remarks
1	VLED+	Power supply	
2	VLED-	Power supply	

3.4 Input Color Data Mapping

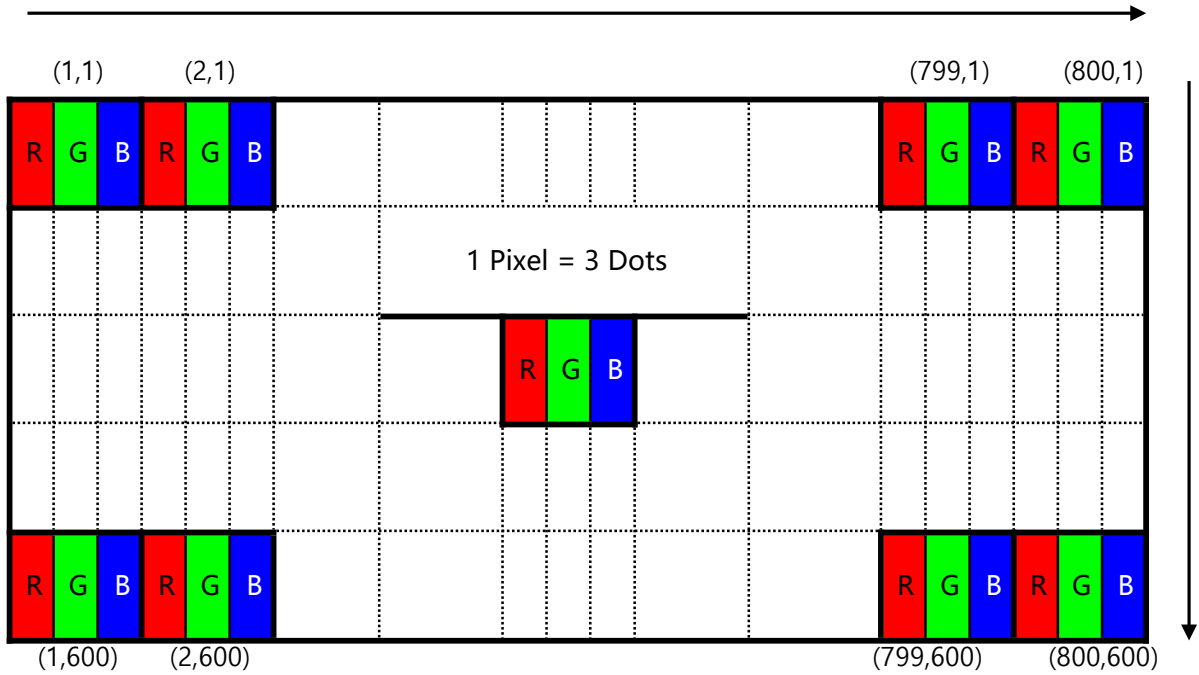

Display Position of Input Data (V-H)

4.0 ELECTRICAL SPECIFICATIONS

4.1 TFT LCD Module

[Ta =25±2 °C]

< Table 3. LCD Module Electrical specifications >

Parameter	Symbol	Values			Unit	Notes
		Min.	Typ.	Max.		
Power Supply Voltage	VDD	3.0	3.3	3.6	V	Note 1
Power Supply Current	IDD	120	150	180	mA	
BLU Supply Voltage	V _{LED}	-	18.6	20.5	V	
BLU Supply Current	I _{LED}	-	100	-	mA	
Power Consumption	P _D	0.4	0.495	0.59	W	Note 2
	P _{LED}	-	-	2.05	W	
	P _{total}	-	-	2.64	W	

Notes : 1. The supply voltage is measured and specified at the interface connector of LCM.
 The current draw and power consumption specified is for VBAT=3.8V, Frame rate f_v=60Hz and Clock frequency = 156.8MHz. Test Pattern of power supply current

a) Typ : Mosaic 8 x 6 Pattern(L0/L255)

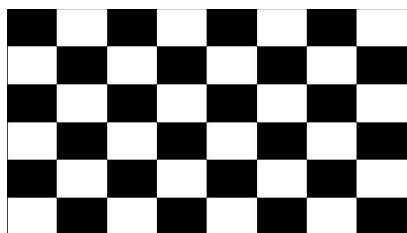

b) Max : skip subPixel(L255)

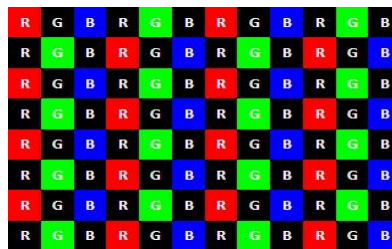

2. The duration of rush current is about 2ms and rising time of Power Input is 1ms(min)

5.0 DC Specification

< Table7. DC Specification >

Parameter	Symbol	Min	Typ	Max	Unit	Condition
Supply current	I_{DD}	120	150	180	mA	
LVDS DC specifications						
Differential input high threshold	V_{TH}	-	-	+100	mV	$V_{IC}=1.2V$
Differential input low threshold	V_{TL}	-100	-	-	mV	
LVDS common mode voltage	V_{IC}	0.7	-	1.6	V	
LVDS swing voltage	V_{ID}	± 100	-	± 600	mV	

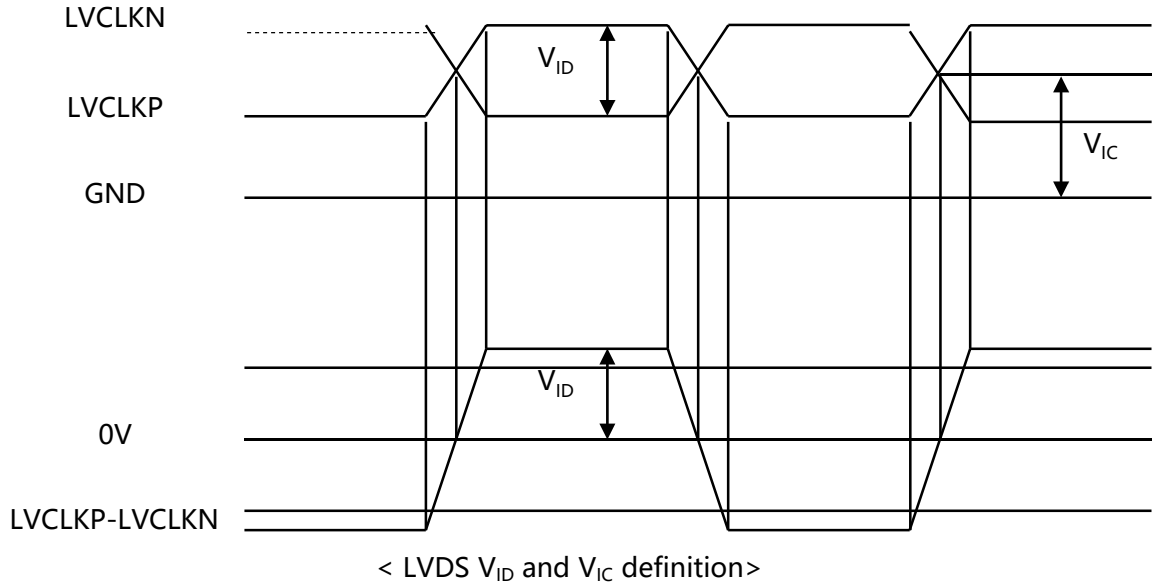

5.1 AC Specification

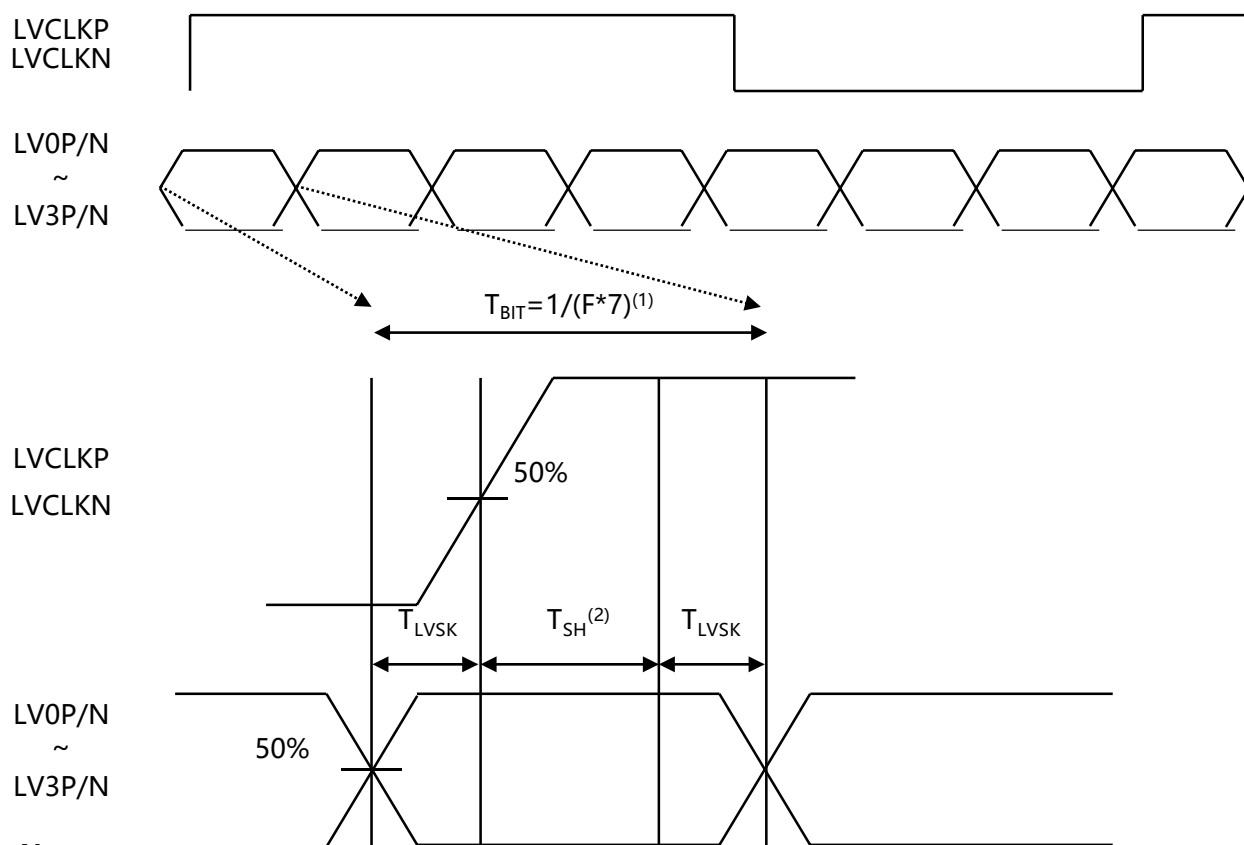

Note:

(1) T_{BIT} : Data period

(2) Internal CLK sampling data window

< LVDS channel to channel skew >

< Table8. AC Specification >

Description	Symbol	Condition	Min	Typ	Max	Unit
LVDS Input frequency	F	-	20	-	85	MHz
LVDS channel to channel skew	T_{LVSK}	F=65MHz $V_{IC}=1.2V$ $V_{ID}=\pm 200mV$	-600	-	+600	ps

5.2 Interface timing Parameter

< Table9. Timing Parameter >

Item		Symbol	min	typ	max	UNIT	
LCD	Frame Rate	-	-	60	-	Hz	
	Pixels Rate	-	37.69	40	68.1	MHz	
Timing	Horizontal	Horizontal total time	tHP	-	860	1300	t _{CLK}
		Horizontal Active time	tHadr	800			t _{CLK}
		Horizontal Back Porch	tHBP	-	30	255	t _{CLK}
		Horizontal Front Porch	tHFP	-	30	245	t _{CLK}
	Vertical	Vertical total time	tvp	620	640	806	t _H
		Vertical Active time	tVadr	600			t _H
		Vertical Back Porch	tVBP	10	20	100	t _H
		Vertical Front Porch	tVFP	10	20	106	t _H
Lane			-	1	-	Lane	

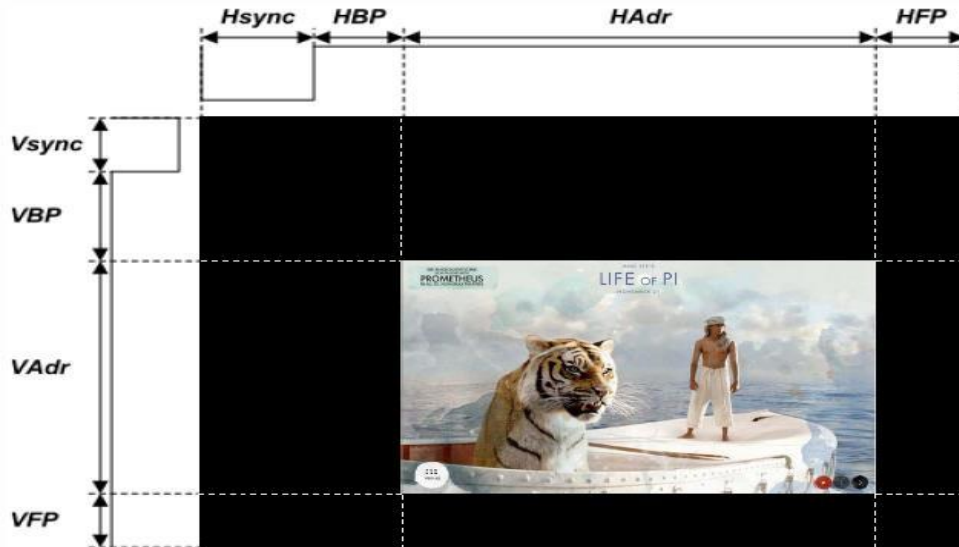

5.3 Power Sequence

[Ta = 25±2 °C]

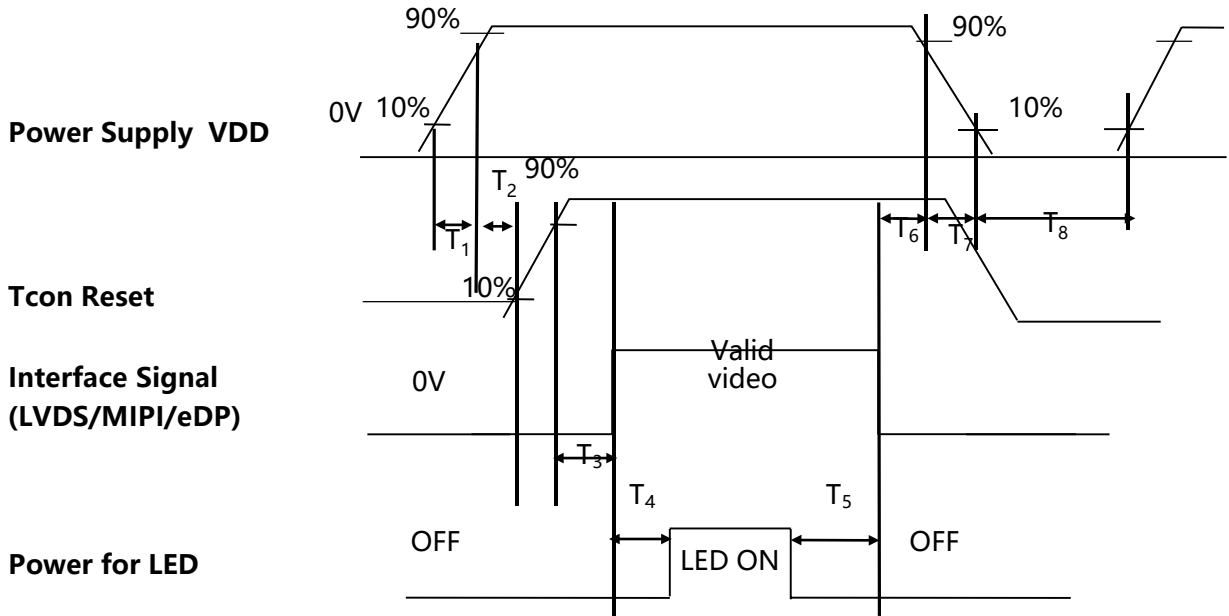

< Table10. Sequence Table >

Parameter	Value			Units
	Min.	Typ.	Max.	
T1	0.1	-	5	(ms)
T2	10	-	30	(ms)
T3	5	-	100	(ms)
T4	200	-	-	(ms)
T5	200	-	-	(ms)
T6	0	-	50	(ms)
T7	0	-	10	(ms)
T8	500	-	-	(ms)

6.0 Back-Light Unit

Table 4. LED Bar Electrical Specifications >

[Ta =25±2 °C]

Parameter	Symbol	Values			Unit	Notes
		Min.	Typ.	Max.		
LED Supply Voltage	V _{LED}	-	18.5	20.5	V	
LED Supply Current	I _{LED}	-	100	-	mA	Note 1
Power Consumption	P _{LED}	-	1.85	2.05	W	
LED Quantity	QLED	-	24	-	EA	
LED Life Time	TLED	30000	-	-	Hrs	Note 2/3

Notes: 1. LED Bar:4Parallel*6String) , I_{LED}=25mA*4=100mA

$$P_{LED} = V_{LED} \times I_{LED} \text{ (Without LED converter transfer efficiency)}$$

2. The life time of LED, 30,000Hrs, is determined as the time at which luminance of the LED is 50% compared to that of initial value at the typical LED current on condition of continuous operating at 25 ± 2°C.
3. Only under the above operating conditions could the life time of LED be guaranteed.

7.0 OPTICAL SPECIFICATIONS

7.1 Overview

The test of optical specifications shall be measured in a dark room (ambient luminance ≤ 1 lux and temperature = $25\pm 2^{\circ}\text{C}$) with the equipment of Luminance meter system (Gonio meter system and TOPCON BM-5) and test unit shall be located at an approximate distance 50cm from the LCD surface at a viewing angle of θ and Φ equal to 0° . We refer to $\theta\emptyset = 0$ ($=\theta 3$) as the 3 o' clock direction (the "right"), $\theta\emptyset = 90$ ($=\theta 12$) as the 12 O' clock direction ("upward"), $\theta\emptyset = 180$ ($=\theta 9$) as the 9 O' clock direction ("left") and $\theta\emptyset = 270$ ($=\theta 6$) as the 6 O' clock direction ("bottom"). While scanning θ and/or \emptyset , the center of the measuring spot on the Display surface shall stay fixed.

Optical Specifications

< Table11. Optical Table >

Item	Symbol	Condition	Min	Typ.	Max	Unit	Note
luminance	Bp	$\theta = 0^{\circ}$	300	350	--	cd/m2	Note 1
Brightness Uniformity	ΔBp		70	80	--	%	Note 2
Viewing Angle	θ_L	Cr ≥ 10	70	80	--	deg	Note 3
	θ_R		70	80	--		
	ψ_T		55	65	--		
	ψ_B		65	75	--		
Contrast Ratio	Cr	$\theta = 0^{\circ}$	600	800		-	Note 4
Response Time	Tr+Tf	FF= 0°	-	30	35	ms	Note 5
Color Coordinate of CIE1931	Rx	$\theta = 0^{\circ}$	0.543	0.593	0.643	-	Note 6
	Ry		0.300	0.350	0.400		
	Gx		0.269	0.319	0.369		
	Gy		0.564	0.614	0.664		
	Bx		0.099	0.149	0.199		
	By		0.020	0.070	0.120		
	Wx		0.235	0.285	0.335		
	Wy		0.265	0.315	0.365		
NTSC Ratio	NTSC	CIE1931	50	55	--	%	Note 7
Polarization Direction of Front Polarizer	PdF			45 $^{\circ}$		deg	Note 8
Polarization Direction of Rear Polarizer	PdR			45 $^{\circ}$		Deg	
Gray inversion angle				6点钟			Note 9

Note1:Luminance measurement

The test condition is at ILED=100mA and measured on the surface of LCD module at 25°C.

- The data are measured after LEDs are lighted on for more than 5 minutes and LCM displays are fully white. The brightness is the center of the LCD. Measurement equipment CS2000 or similar equipments (Field of view:1deg,Distance:50cm)
- Measuring surroundings: Dark room.
- Measuring temperature: Ta=25°C.
- Adjust operating voltage to get optimum contrast at the center of the display.
- Measured value at the center point of LCD panel must be after more than 5 minutes while backlight turning on.

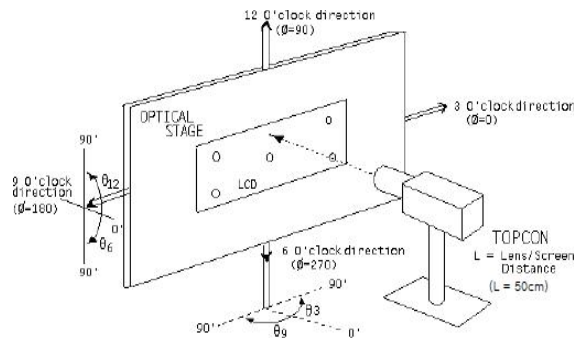

Note2:Uniformity

- The test condition is at ILED=100mA and measured on the surface of LCD module at 25°C.
- Measurement equipment:CS2000 or similar equipments
- The luminance uniformity is calculated by using following formula:
- $\Delta Bp = Bp \text{ (Min.)} / Bp \text{ (Max.)} \times 100 \text{ (\%)}$
- $Bp \text{ (Max.)} = \text{Maximum brightness in 9 measured spots}$
- $Bp \text{ (Min.)} = \text{Minimum brightness in 9 measured spots.}$

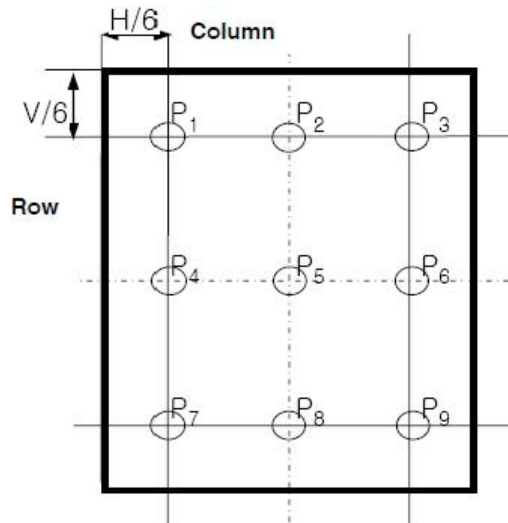

Note 6: Color Coordinates of CIE 1931

The test condition is at ILED=100mA and measured on the surface of LCD module at 25°C.

Measurement equipment:CS2000 or similar equipments

The Color Coordinate (CIE 1931) is the measurement of the center of the display shown in below figure.

Note 7: Definition of Color of CIE Coordinate and NTSC Ratio.

$$S = \frac{\text{area of RGB triangle}}{\text{area of NTSC triangle}} \times 100\%$$

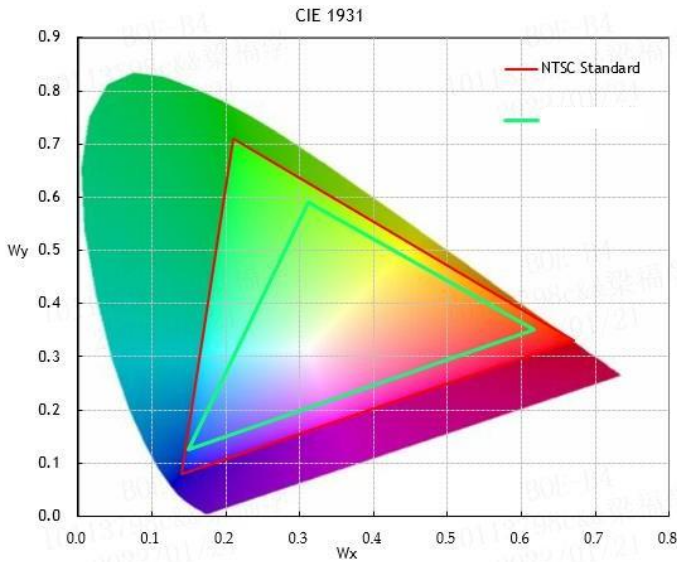

Note 8: Polarization Direction Definition

- Viewing direction is normal user viewing direction which is vertical to the display surface
- The polarizer which is closer to viewer is defined as Front Polarizer
- The polarizer which is on the rear side of viewer is defined as Rear Polarizer
- The X axis is defined as parallel line to top & bottom sidelines of the Active Area
- PdF which is marked in blue arrow is polarization degree of Front polarizer
- PdR which is marked in red arrow is polarization degree of Back polarizer
- The polarization degree parameter must be indicated in range of 0deg to 180deg according to above definition

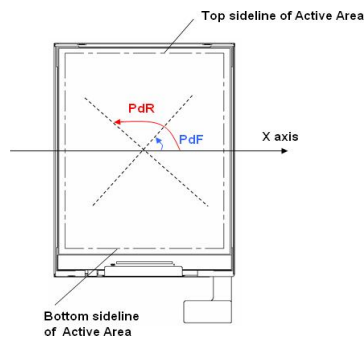

Note 9: Definition of gray inversion angle

- Refer to the graph of note 9.
- Using luminance test method.
- Test pattern : 128 gray
- If the viewing direction is 12 o' clock ,then test the luminance while $\theta = -60^\circ, \theta = -50^\circ, \theta = -40^\circ, \theta = -30^\circ, \theta = -20^\circ, \theta = -10^\circ, \theta = 0^\circ, \theta = 10^\circ, \theta = 20^\circ, \theta = 30^\circ, \theta = 40^\circ, \theta = -50^\circ, \theta = 60^\circ$. The luminance test as figure below:

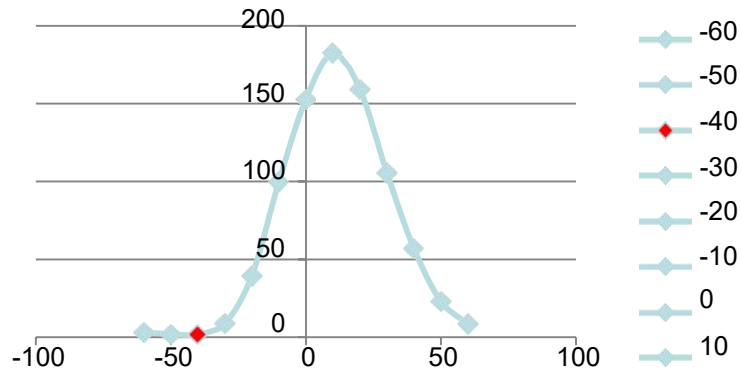

8.0 RELIABILITY TEST

The Reliability test items and its conditions are shown in below.

<Table 12. Reliability Test Parameters >

NO.	Test Item	Test Condition	Duration
1	High temperature, high humidity operation test(THO)	60°C, 90%RH	240hrs
2	Low temperature operation test(LTO)	-20 °C	240hrs
3	High temperature operation test(HTO)	70 °C	240hrs
4	High temperature storage test(HTS)	80°C	240hrs
5	Low temperature storage test(LTS)	-30°C	240hrs
6	Thermal shock test (TST)	-30 °C → 80 °C (Per 30min)	100hrs
7	ESD	150pF 330Ω ±8KV(Air) / ±6KV(Contact)	20points
8	Packin VIB	1.47G, 1-200hz, X, Y, ±Z,	30min/Axis

9. Definition Of Labels

The barcode nameplate is pasted on each module as illustration, and its definitions are as following explanation.



(a)Model Name: G104XL20-S01

(b)Serial ID: XXXXX YW XXXXXX

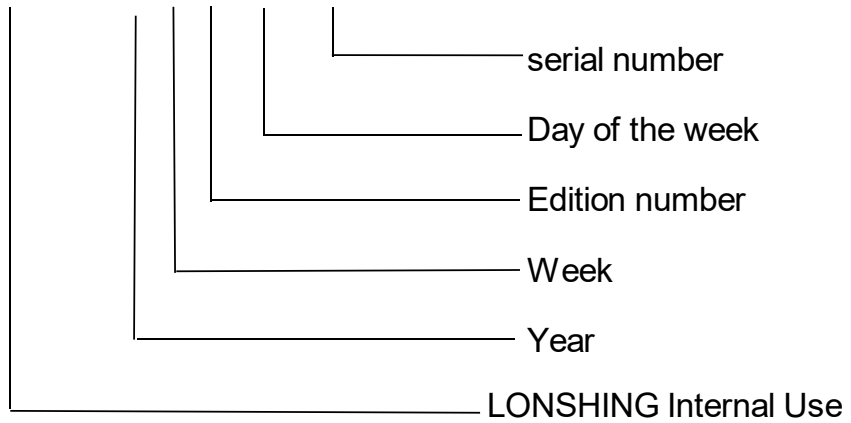

Serial ID includes the information as below:

(a)Manufactured Date:

Year:00~99,...2019=19, 2020=20, 2021=21...,2028=28.
 Week:01~56,first week of the year=01;second week of the year=02;...
 Day of the week:A~G=Monday~Sunday

(b) Edition number: cover all the change; A1,A2...Sample order;
 C for mass production, C1, C2... change of order

(c) Serial No.: Manufacturing sequence of product

11. Packaging

TBD

12. PRECAUTIONS

12.1 ASSEMBLY AND HANDLING PRECAUTIONS

- (1) The module should be assembled into the system firmly by using every mounting hole. Be careful not to twist or bend the module.
- (2) While assembling or installing modules, it can only be in the clean area. The dust and oil may cause electrical short or damage the polarizer.
- (3) Use fingerstalls or soft gloves in order to keep display clean during the incoming inspection and assembly process.
- (4) Do not press or scratch the surface harder than a HB pencil lead on the panel because the polarizer is very soft and easily scratched.
- (5) If the surface of the polarizer is dirty, please clean it by some absorbent cotton or soft cloth. Do not use Ketone type materials (ex. Acetone), Ethyl alcohol, Toluene, Ethyl acid or Methyl chloride. It might permanently damage the polarizer due to chemical reaction.
- (6) Wipe off water droplets or oil immediately. Staining and discoloration may occur if they left on panel for a long time.
- (7) If the liquid crystal material leaks from the panel, it should be kept away from the eyes or mouth. In case of contacting with hands, legs or clothes, it must be washed away thoroughly with soap.
- (8) Protect the module from static electricity, it may cause damage to the C-MOS Gate Array IC.
- (9) Do not disassemble the module.
- (10) Do not pull or fold the lamp wire.
- (11) Pins of I/F connector should not be touched directly with bare hands.

12.2 STORAGE PRECAUTIONS

- (1) When storing for a long time, the following precautions are necessary.
 - (a) Store them in a dark place. Do not expose the module to sunlight or fluorescent light. Keep the temperature between 5°C and 30°C at humidity 50+-10%RH.
 - (b) The polarizer surface should not come in contact with any other object.
 - (c) It is recommended that they be stored in the container in which they were shipped.
 - (d) Storage condition is guaranteed under packing conditions.
 - (e) The phase transition of Liquid Crystal in the condition of the low or high storage temperature will be recovered when the LCD module returns to the normal condition
-

- (2) High temperature or humidity may reduce the performance of module. Please store LCD module within the specified storage conditions.
- (3) It is dangerous that moisture come into or contacted the LCD module, because the moisture may damage LCD module when it is operating.
- (4) It may reduce the display quality if the ambient temperature is lower than 10 °C. For example, the response time will become slowly, and the starting voltage of lamp will be higher than the room temperature.

12.3 OTHER PRECAUTIONS

- (1) Normal operating condition
 - (a) Display pattern: dynamic pattern (Real display)
 - (Note) Long-term static display can cause image sticking.
 - (2) Operating usages to protect against image sticking due to long-term static display
 - (a) Suitable operating time: under 16 hours a day.
 - (b) Static information display recommended to use with moving image.
 - (c) Cycling display between 5 minutes' information(static) display and 10 seconds' moving image.
 - (3) Abnormal condition just means conditions except normal condition.
-