



深圳市宇华微科技有限公司

PRODUCT SPECIFICATION

Doc. Number:

- Tentative Specification
- Preliminary Specification
- Approval Specification

MODEL NO.: GV057BQV01
SUFFIX: L01

| | |
|---|------------------|
| Customer: | |
| APPROVED BY | SIGNATURE |
| Name / Title _____ | |
| Note : _____ | |
| Please return 1 copy for your confirmation with your signature and comments . | |

| Approved By | Checked By | Prepared By |
|-------------|------------|-------------|
| | | MW Chen |

Table of Contents

| No. | Item |
|------|---|
| 1. | General Description |
| 2. | Module Parameter |
| 3. | Absolute Maximum Ratings |
| 4. | DC Characteristics |
| 5. | Backlight Characteristic |
| 5.1 | Backlight Unit |
| 5.2 | Backlight Characteristics |
| 5.3 | Backlighting circuit |
| 6. | Optical Characteristics |
| 6.1 | Optical Characteristics |
| 6.2 | Definition of Response Time |
| 6.3 | Definition of Contrast Ratio |
| 6.4 | Definition of Viewing Angles |
| 6.5 | Definition of Color Appearance |
| 6.6 | Definition of Surface Luminance, Uniformity and Transmittance |
| 7. | Block Diagram and Power Supply |
| 8. | Interface Pins Definition |
| 9. | AC Characteristics |
| 10. | Quality Assurance |
| 10.1 | Purpose |
| 10.2 | Standard for Quality Test |
| 10.3 | Nonconforming Analysis & Disposition |
| 10.4 | Agreement Items |
| 10.5 | Standard of the Product Visual Inspection |
| 10.6 | Inspection Specification |
| 10.7 | Classification of Defects |
| 10.8 | Identification/marketing criteria |
| 10.9 | Packaging |
| 11. | Reliability Specification |
| 12. | Precautions and Warranty |
| 12.1 | Safety |
| 12.2 | Handling |
| 12.3 | Storage |
| 12.4 | Metal Pin (Apply to Products with Metal Pins) |
| 12.5 | Operation |
| 12.6 | Static Electricity |
| 12.7 | Limited Warranty |
| 13. | Packaging |
| 14. | Outline Drawing |

1. General Description

G057BQV01 is a 5.7 inch IAV TFT Liquid Crystal Display module with a LED backlight unit and a 20pin 6bit LVDS interface controller board. The converter for the LED Backlight Unit is built in. This module supports 640 (R.G.B) x 480 WVGA mode which main application is the automotive display and industrial field.

2. Module Parameter

| Features | Details | Unit |
|--------------------------------|-------------------------------|------------|
| Display Size(Diagonal) | 5.7" | |
| LCD type | IPS TFT | |
| Display Mode | Transmissive /Normally Black | |
| Resolution | 640 RGB x 480 | Pixels |
| View Direction | Full View | Best Image |
| Gray Scale Inversion Direction | - | |
| Module Outline | 126.5(W) x 100(H) x 7.6(D) mm | mm |
| Active Area | 115.2(H) x114.15(V) | mm |
| Pixel Size | 60 x180 | um |
| Pixel Arrangement | R.G.B. Vertical Stripe | |
| Display Colors | 16.7M | |
| Interface | LVDS interface | |
| With or without touch panel | without | |
| Driver IC | | - |
| Operating Temperature | -30~80 | °C |
| Storage Temperature | -30~85 | °C |
| Weight | - | g |

3. Absolute Maximum Ratings

V_{SS}=0V, Ta=25°C

| Item | Symbol | Min. | Max. | Unit |
|-----------------------|------------------|------|------|------|
| Supply Voltage | V _{CI} | -0.3 | 5.0 | V |
| Storage temperature | T _{stg} | -30 | +85 | °C |
| Operating temperature | T _{op} | -30 | +80 | °C |

Note 1: If Ta below 50°C, the maximal humidity is 90%RH, if Ta over 50°C, absolute humidity should be less than 60%RH.

Note 2: The response time will be extremely slow when the operating temperature is around -10°C, and the back ground will become darker at high temperature operating.

4. DC Characteristics

| Item | Symbol | Min. | Typ. | Max. | Unit | |
|----------------------------------|-----------------|-----------------------------------|------|---------------------|------|----|
| Supply Voltage | V _{CI} | 2.5 | 3.0 | 3.3 | V | |
| Logic Low input voltage | V _{IL} | GND | - | 0.3*V _{CI} | V | |
| Logic High input voltage | V _{IH} | 0.7*V _{CI} | - | V _{CI} | V | |
| Logic Low output voltage | V _{OL} | GND | - | 0.2*V _{CI} | V | |
| Logic High output voltage | V _{OH} | 0.8*V _{CI} | - | V _{CI} | V | |
| Current Consumption All Black | Logic | I _{CC} + I _{IN} | - | 9 | - | mA |
| | Analog | | | | | |

5. Backlight Characteristic

T_a = 25 ± 2 °C

5.1 BACKLIGHT UNIT

| Parameter | Symbol | Value | | | Unit | Note |
|--------------------------------|------------------|-------|--------|-------|------|---------------------------------------|
| | | Min. | Typ. | Max. | | |
| Converter Power Supply Voltage | V _i | 10.8 | 12.0 | 13.2 | V | |
| Converter Power Supply Current | I _i | --- | 0.24 | 0.264 | A | @ V _i = 12V (Duty 100%) |
| Converter Power Consumption | P _{LED} | --- | 2.8 | 3.08 | W | @ V _i = 12V (Duty 100%) |
| EN Control Level | Backlight on | 2.5 | --- | 5 | V | |
| | Backlight off | 0 | --- | 0.3 | V | |
| PWM Control Voltage | | 0.7 | --- | 2.5 | V | |
| PWM Control Duty Ratio | | 10 | | 100 | % | |
| PWM Control Frequency | f _{PWM} | 100 | | 500 | Hz | |
| LED Life Time | L _L | | 50,000 | | Hrs | (2) |

Note (1) LED current is measured by utilizing a high frequency current meter as shown below:

Note (2) The lifetime of LED is defined as the time when it continues to operate under the conditions at T_a = 25 ± 2 °C and I_{LED} = 50mA_{DC} (LED forward current) until the brightness becomes ≤ 50% of its original value.

Note (3) Please note that LED life will be shorter than the average life described in the specification if operate in higher ambient temperature.

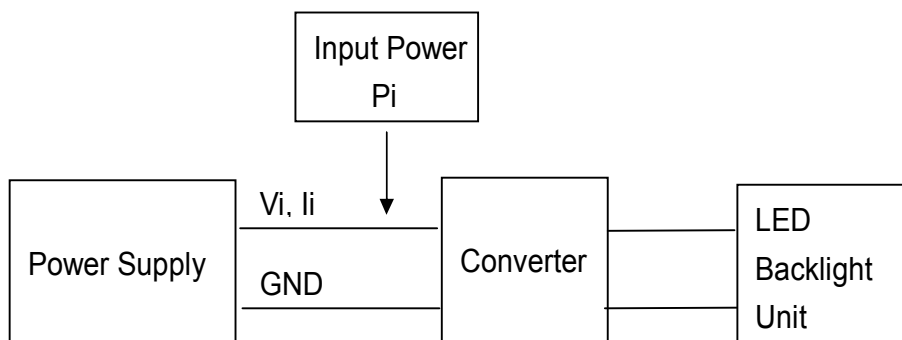

5.2. Backlight

| Item | Symbol | Condition | Min. | Typ. | Max. | Unit |
|--|--|--|------|--------|------|------|
| Forward Voltage | V_F | $T_a=25\text{ }^\circ\text{C}$, $I_F=20\text{mA/LED}$ | 8.2 | 9.2 | 10.5 | V |
| Forward Current | I_F | $T_a=25\text{ }^\circ\text{C}$, $V_F=3.0\text{V/LED}$ | - | 160 | - | mA |
| Power dissipation | P_D | | - | 1260 | - | mW |
| Uniformity | Avg | | 80 | - | - | % |
| LED working life(25°C) | - | | - | 50,000 | - | Hrs |
| Drive method | Constant current | | | | | |
| LED Configuration | 24 White LEDs (3 LEDs in one string and 8 groups in parallel) | | | | | |

Note1: LED life time defined as follows: The final brightness is at 50% of original brightness.
The environmental conducted under ambient air flow, at $T_a=25\pm 2\text{ }^\circ\text{C}$, $60\%\text{RH}\pm 5\%$, $I_F=20\text{mA/LED}$.

5.3. Backlighting circuit

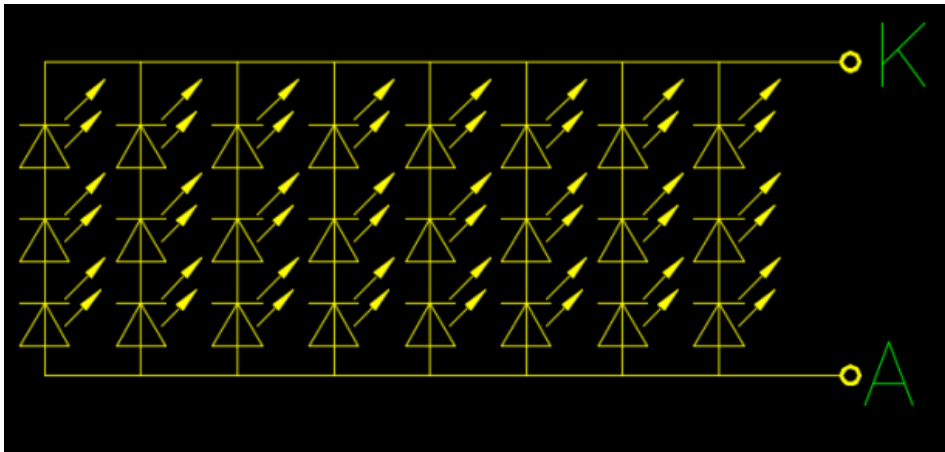

6. Optical Characteristics

6.1. Optical Characteristics

Ta=25°C, VCI=2.8V

| Backlight On (Transmissive Mode) | Item | Symbol | Condition | Specification | | | Unit | |
|----------------------------------|--|--------------------------------|--|-----------------|------|------|-------------------|------|
| | | | | Min. | Typ. | Max. | | |
| | Luminance | Lv | Normally viewing angle $\theta_x = \varphi_y = 0^\circ$ | 400 | 500 | - | cd/m ² | |
| | Contrast ratio(See 6.3) | CR | | 1000 | 1200 | - | | |
| | Response time (See 6.2) | T _R +T _F | | - | 30 | 35 | ms | |
| | Chromaticity Transmissive (See 6.5) | White | | X _W | - | - | - | |
| | | | Y _W | - | - | - | | |
| | Viewing Angle (See 6.4) | Horizontal | Center CR≥10 | θ _{x+} | 75 | 80 | - | Deg. |
| | | | | θ _{x-} | 75 | 80 | - | |
| | | Vertical | | φ _{y+} | 75 | 80 | - | |
| | | | | φ _{y-} | 75 | 80 | - | |
| | NTSC Ratio(Gamut) | | | 55 | 60 | - | % | |

6.2. Definition of Response Time

6.2.1. Normally Black Type (Negative)

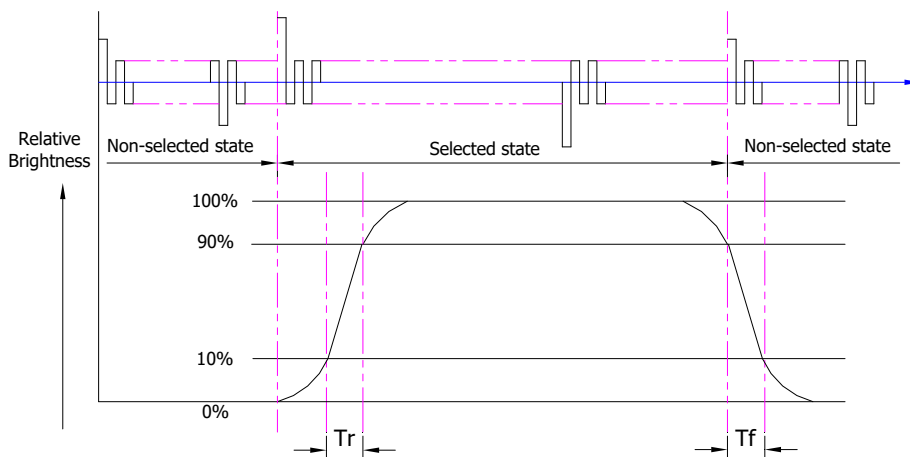

T_r is the time it takes to change from non-selected state with relative luminance 10% to selected state with relative luminance 90%;

T_f is the time it takes to change from selected state with relative luminance 90% to non-selected state with relative luminance 10%.

Note : Measuring machine: LCD-5100

6.2.2. Normally White Type (Positive)

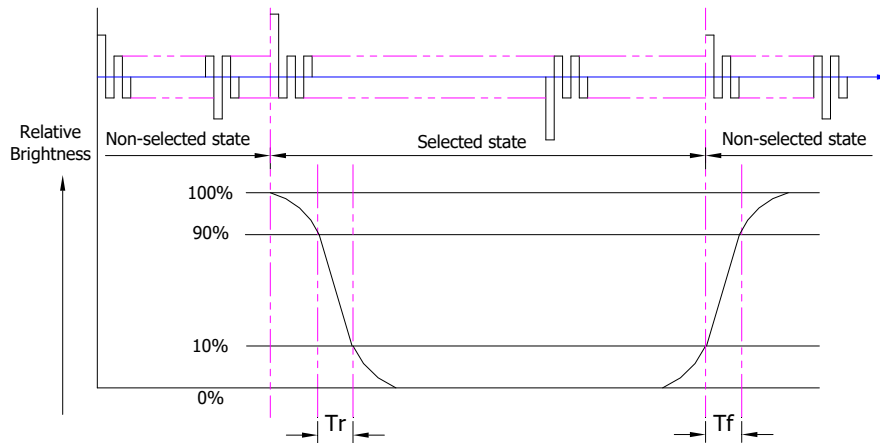

Tr is the time it takes to change from non-selected state with relative luminance 90% to selected state with relative luminance 10%;

Tf is the time it takes to change from selected state with relative luminance 10% to non-selected state with relative luminance 90%;

Note: Measuring machine: LCD-5100 or EQUI

6.3. Definition of Contrast Ratio

Contrast is measured perpendicular to display surface in reflective and transmissive mode.

The measurement condition is:

| | |
|--------------------------|--------------------------|
| Measuring Equipment | Eldim or Equivalent |
| Measuring Point Diameter | 3mm//1mm |
| Measuring Point Location | Active Area centre point |
| Test pattern | A: All Pixels white |
| | B: All Pixel black |
| Contrast setting | Maximum |

Definitions: CR (Contrast) = Luminance of White Pixel / Luminance of Black Pixel

6.4. Definition of Viewing Angles

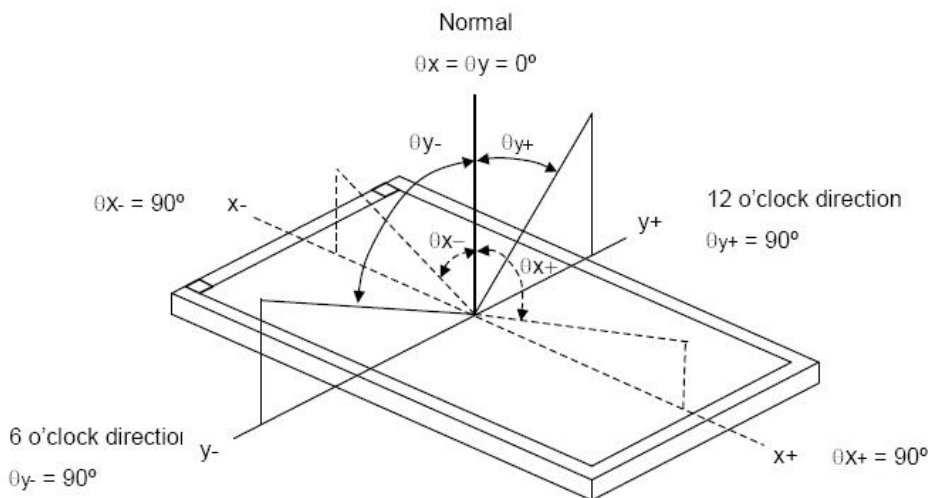

Measuring machine: LCD-5100 or EQUI

6.5. Definition of Color Appearance

R,G,B and W are defined by (x, y) on the IE chromaticity diagram

NTSC=area of RGB triangle/area of NTSC triangleX100%

Measuring picture: Red, Green, Blue and White (Measuring machine: BM-7)

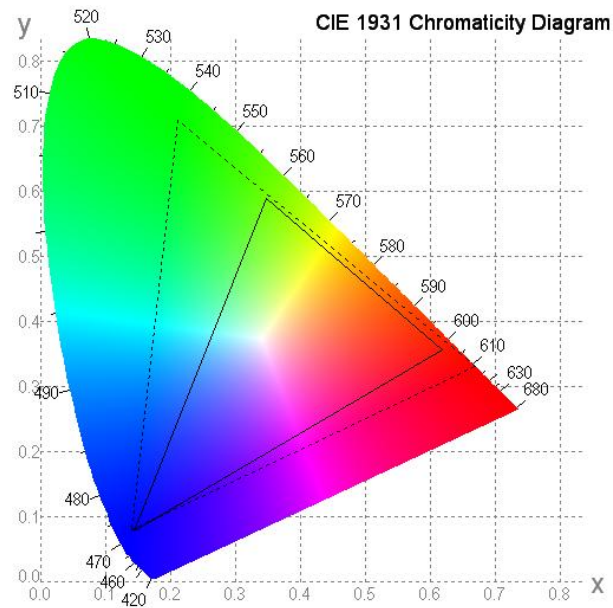

6.6. Definition of Surface Luminance, Uniformity and Transmittance

Using the transmissive mode measurement approach, measure the white screen luminance of the display panel and backlight.

6.6.1. Surface Luminance: $L_V = \text{average}(L_{P1}:L_{P9})$

6.6.2. Uniformity = $\text{Minimal}(L_{P1}:L_{P9}) / \text{Maximal}(L_{P1}:L_{P9}) * 100\%$

6.6.3. Transmittance = $L_V \text{ on LCD} / L_V \text{ on Backlight} * 100\%$

Note: Measuring machine: BM-7

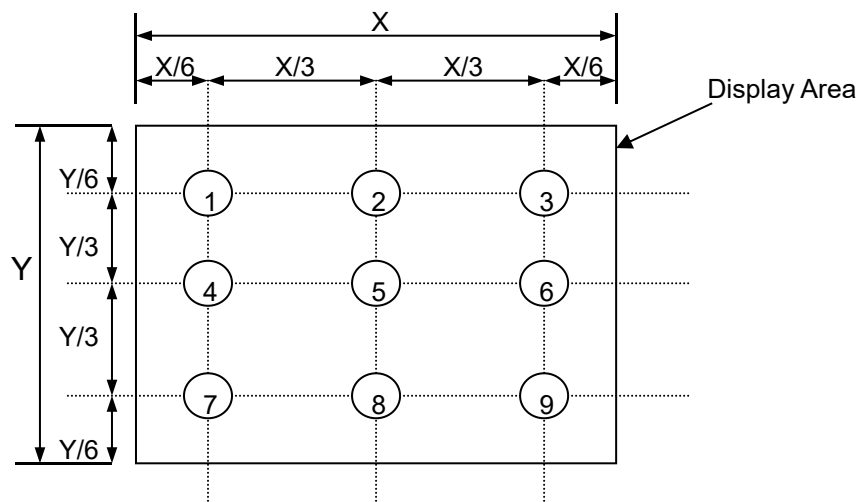

7. Block Diagram and Power Supply

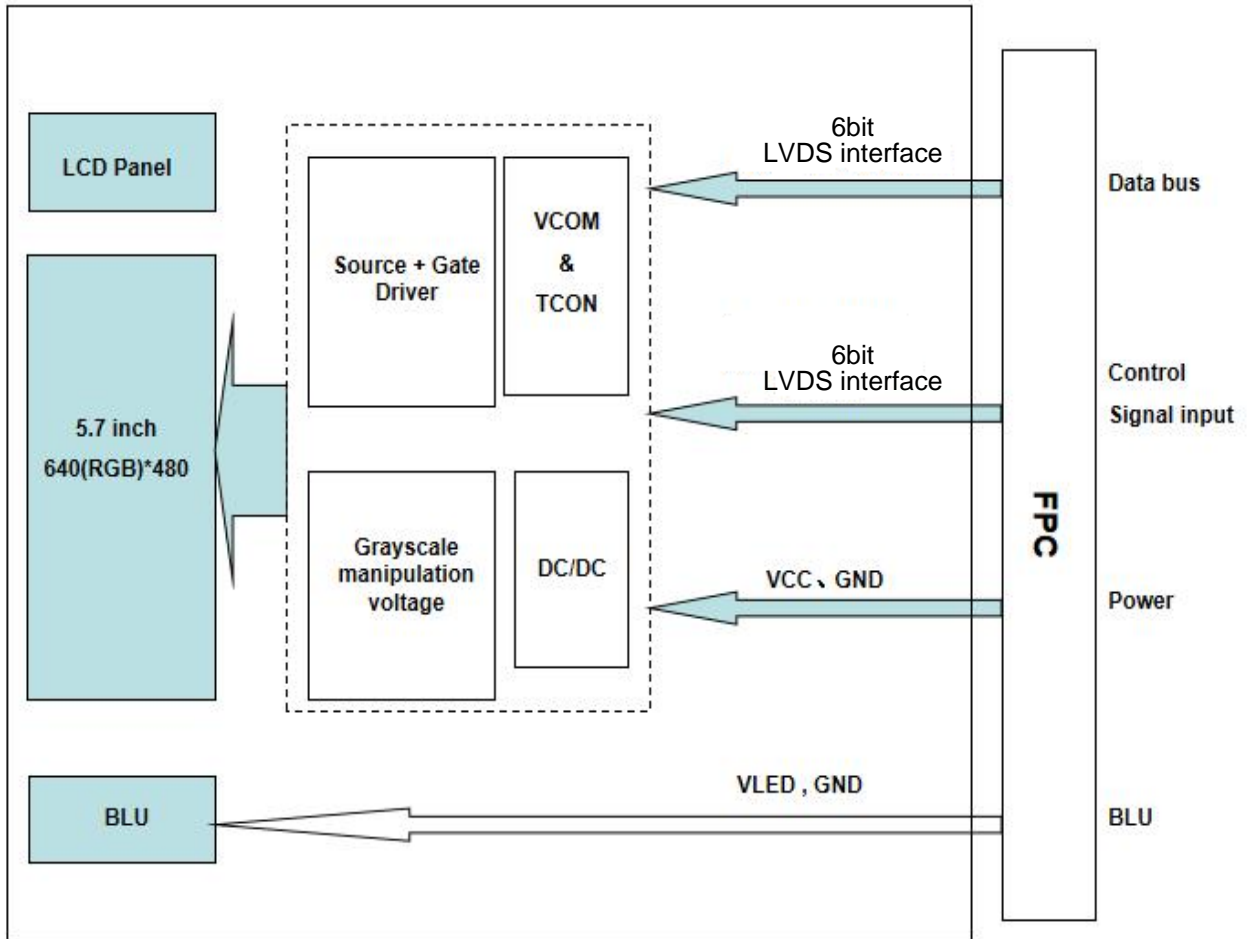

8. Interface Pins Definition

8.1 LVDS I/O PIN ASSIGNMENT

CN1

| Pin | Name | I/O | Description |
|-----|--------|-----|-------------------------------------|
| 1 | VCC_IN | I | Digital power supply (+3.3V) |
| 2 | VCC_IN | I | Digital power supply (+3.3V) |
| 3 | GND | I | Ground |
| 4 | GND | I | Ground |
| 5 | RX0- | I | LVDS differential data input Pair 0 |
| 6 | RX0+ | I | |
| 7 | GND | I | Ground |
| 8 | RX1- | I | LVDS differential data input Pair 1 |
| 9 | RX1+ | I | |
| 10 | GND | I | Ground |
| 11 | RX2- | I | LVDS differential data input Pair 2 |
| 12 | RX2+ | I | |
| 13 | GND | I | Ground |
| 14 | RXC- | I | LVDS differential Clock input Pair |
| 15 | RXC+ | I | |
| 16 | NC | I | No Connected |
| 17 | NC | I | No Connected |
| 18 | NC | I | No Connected |
| 19 | NC | I | No Connected |
| 20 | NC | I | No Connected |

Note (1) Connector Part No.: 076B20-0048RA-G4, Starconn or equivalent

8.2 BACKLIGHT PIN ASSIGNMENT (Converter connector pin)

CN3

| No | Symbol | I/O | Description |
|----|--------|-----|-----------------------------|
| 1 | VLED | I | Converter input voltage 12V |
| 2 | GND | I | Converter ground |
| 3 | EN | I | Enable pin |
| 4 | PWM | I | Control Duty Ratio |
| 5 | NC | I | No Connected |

9. AC Characteristics

Vertical Timings

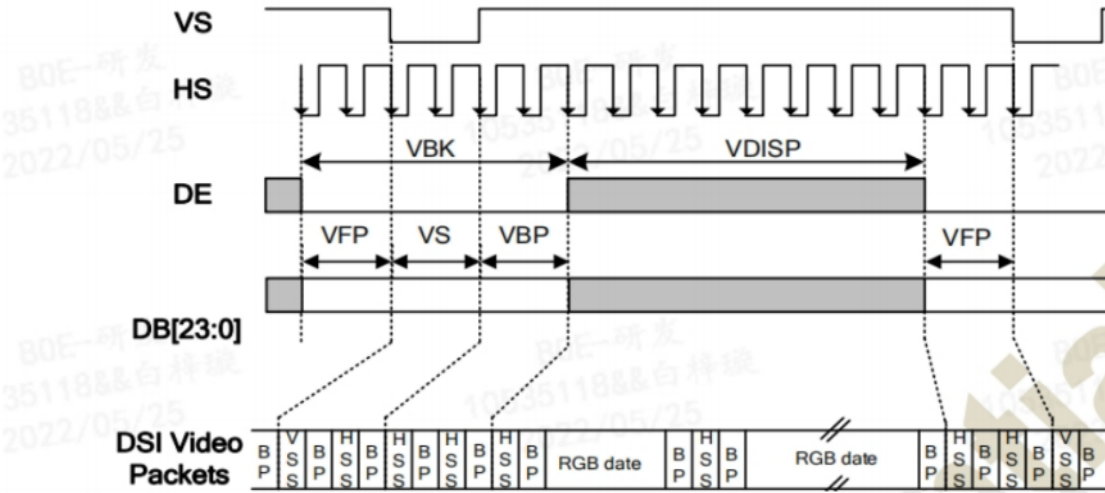

| Item | Symbol | Condition | Min. | Typ. | Max. | Unit |
|--------------------------|--------|------------|------|------|---------------------|------|
| Vertical low pulse width | VS | - | 2 | - | Note ⁽¹⁾ | Line |
| Vertical front porch | VFP | - | 2 | - | - | Line |
| Vertical back porch | VBP | - | 2 | - | Note ⁽¹⁾ | Line |
| Vertical blanking period | VBK | VS+VBP+VFP | 6 | - | - | Line |
| Vertical active area | - | VDISP | - | 480 | - | Line |
| Vertical Refresh rate | VRR | - | - | 60 | - | Hz |

Horizontal Timings

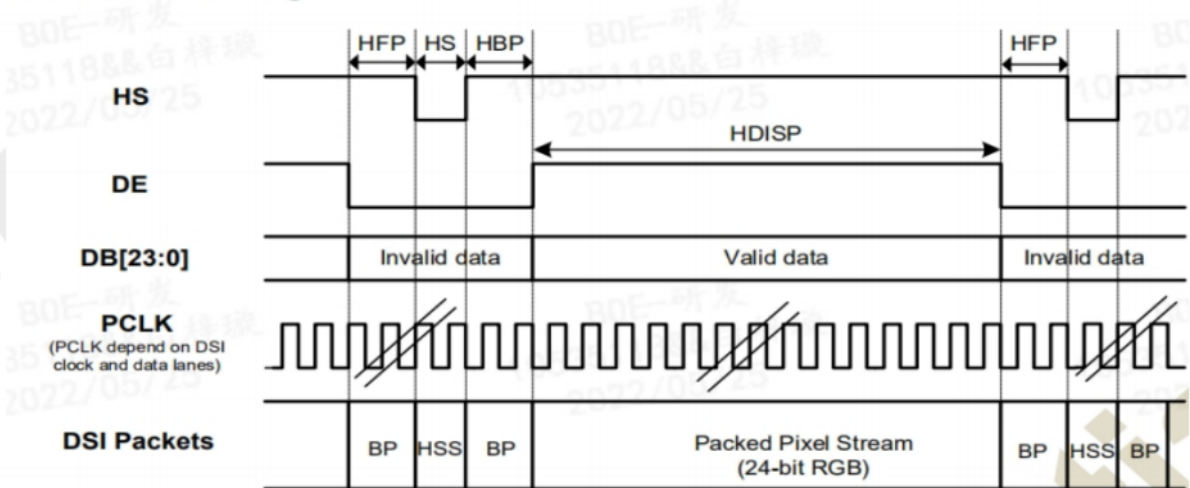

| Item | Symbol | Condition | Min. | Typ. | Max. | Unit |
|----------------------------|--------|------------|------|--------------------|------|------|
| HS low pulse width | HS | - | 100 | | | ns |
| Horizontal back porch | HBP | - | 100 | | | ns |
| Horizontal front porch | HFP | - | 400 | | | ns |
| Horizontal blanking period | HBLK | HS+HBP+HFP | | 900 ⁽¹⁾ | | ns |
| Horizontal active area | HDISP | 800 pixels | - | 12 ⁽²⁾ | - | us |

Remark : Porch setting is related to MCU PCLK and Frames

10. Quality Assurance

10.1.Purpose

This standard for Quality Assurance assures the quality of LCD module products supplied to customer.

10.2.Standard for Quality Test

10.2.1. Sampling Plan:

GB2828.1-2012

Single sampling, general inspection level II

10.2.2. Sampling Criteria:

Visual inspection: AQL 1.5%

Electrical functional: AQL 0.65%.

10.2.3. Reliability Test:

Detailed requirement refer to Reliability Test Specification.

10.3.Nonconforming Analysis & Disposition

10.3.1. Nonconforming analysis:

10.3.1.1. Customer should provide overall information of non-conforming sample for their complaints.

10.3.1.2. After receipt of detailed information from customer, the analysis of nonconforming parts usually should be finished in one week.

10.3.1.3. If cannot finish the analysis on time, customer will be notified with the progress status.

10.3.2. Disposition of nonconforming:

10.3.2.1. Non-conforming product over PPM level will be replaced.

10.3.2.2. The cause of non-conformance will be analyzed. Corrective action will be discussed and implemented.

10.4.Agreement Items

Shall negotiate with customer if the following situation occurs:

10.4.1. There is any discrepancy in standard of quality assurance.

10.4.2. Additional requirement to be added in product specification.

10.4.3. Any other special problem.

10.5.Standard of the Product Visual Inspection

10.5.1. Appearance inspection:

10.5.1.1. The inspection must be under illumination about 1000 – 1500 lx, and the distance of view must be at 30cm ± 2cm.

10.5.1.2. The viewing angle should be 45° from the vertical line without reflection light or follows customer's viewing angle specifications.

10.5.1.3. Definition of area: A Zone: Active Area, B Zone: Viewing Area,

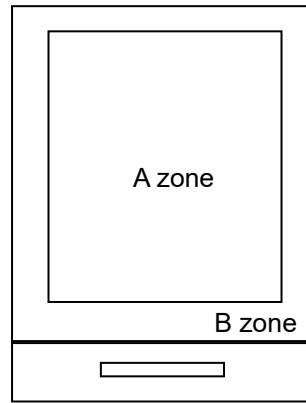
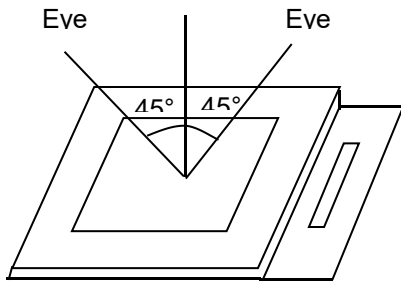

10.5.2. Basic principle:

10.5.2.1. A set of sample to indicate the limit of acceptable quality level must be discussed by both us and customer when there is any dispute happened.

10.5.2.2. New item must be added on time when it is necessary.

10.6. Inspection Specification

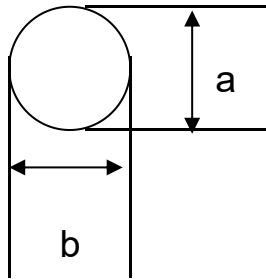
| No. | Item | Criteria (Unit: mm) | | | | | | | | | | | | | | | | | | |
|----------------------------|---|--|-------------|--------------|---------------------|--------|----------------------------|----------|----------------------------|-------|------------------|--------------|--------------|----------------------------------|--------------|--------------|-------------|---|--|-------|
| 01 | Black / White spot Foreign material (Round type) Pinholes Stain Particles inside cell. (Minor defect) | <div style="display: flex; align-items: center;">  <table border="1" style="margin-left: 20px;"> <thead> <tr> <th>Size \ Area</th> <th>Acc. Qty</th> </tr> </thead> <tbody> <tr> <td>$\varphi \leq 0.10$</td> <td>Ignore</td> </tr> <tr> <td>$0.10 < \varphi \leq 0.15$</td> <td>2</td> </tr> <tr> <td>$0.15 < \varphi \leq 0.25$</td> <td>1</td> </tr> <tr> <td>$0.25 < \varphi$</td> <td>0</td> </tr> <tr> <td>Total</td> <td>2 no include $\varphi \leq 0.10$</td> </tr> </tbody> </table> </div> <p>$\varphi = (a + b) / 2$ Distance between 2 defects should more than 3mm apart.</p> | Size \ Area | Acc. Qty | $\varphi \leq 0.10$ | Ignore | $0.10 < \varphi \leq 0.15$ | 2 | $0.15 < \varphi \leq 0.25$ | 1 | $0.25 < \varphi$ | 0 | Total | 2 no include $\varphi \leq 0.10$ | | | | | | |
| Size \ Area | Acc. Qty | | | | | | | | | | | | | | | | | | | |
| $\varphi \leq 0.10$ | Ignore | | | | | | | | | | | | | | | | | | | |
| $0.10 < \varphi \leq 0.15$ | 2 | | | | | | | | | | | | | | | | | | | |
| $0.15 < \varphi \leq 0.25$ | 1 | | | | | | | | | | | | | | | | | | | |
| $0.25 < \varphi$ | 0 | | | | | | | | | | | | | | | | | | | |
| Total | 2 no include $\varphi \leq 0.10$ | | | | | | | | | | | | | | | | | | | |
| 02 | Electrical Defect (Minor defect) | <table border="1" style="width: 100%;"> <thead> <tr> <th></th> <th>Display Area</th> <th>Total</th> <th></th> </tr> </thead> <tbody> <tr> <td>Bright dot</td> <td>0</td> <td>0</td> <td rowspan="3">Note1</td> </tr> <tr> <td>Dark dot</td> <td>N ≤ 2</td> <td>N ≤ 2</td> </tr> <tr> <td>Total dot</td> <td>N ≤ 2</td> <td>N ≤ 2</td> </tr> <tr> <td>Mura</td> <td colspan="2">Not visible through 5% ND filters.</td> <td>Note2</td> </tr> </tbody> </table> <p>Remark: 1. Bright dot caused by scratch and foreign object accords to item 1.</p> | | Display Area | Total | | Bright dot | 0 | 0 | Note1 | Dark dot | N ≤ 2 | N ≤ 2 | Total dot | N ≤ 2 | N ≤ 2 | Mura | Not visible through 5% ND filters. | | Note2 |
| | Display Area | Total | | | | | | | | | | | | | | | | | | |
| Bright dot | 0 | 0 | Note1 | | | | | | | | | | | | | | | | | |
| Dark dot | N ≤ 2 | N ≤ 2 | | | | | | | | | | | | | | | | | | |
| Total dot | N ≤ 2 | N ≤ 2 | | | | | | | | | | | | | | | | | | |
| Mura | Not visible through 5% ND filters. | | Note2 | | | | | | | | | | | | | | | | | |

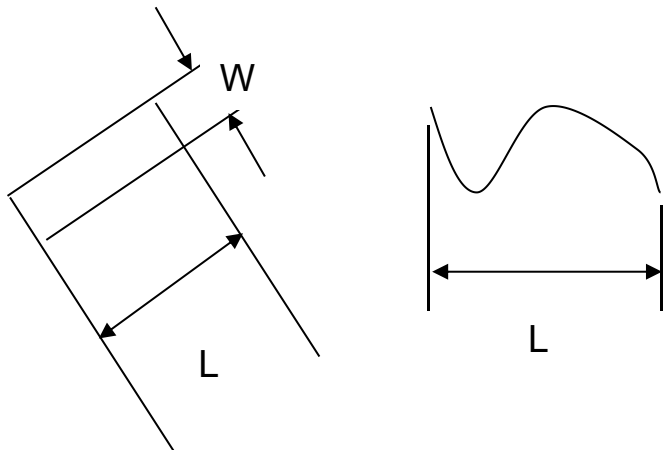
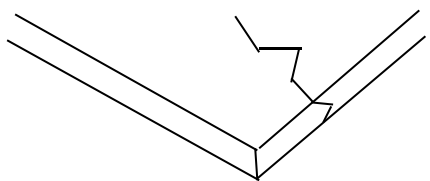
| 03 | <p>Black and White line Scratch Foreign material (Line type) (Minor defect)</p> |  <table border="1" data-bbox="614 828 1241 1137"> <thead> <tr> <th>Length</th> <th>Width</th> <th>Acc. Qty</th> </tr> </thead> <tbody> <tr> <td>/</td> <td>$W \leq 0.03$</td> <td>Ignore</td> </tr> <tr> <td>$L \leq 2.5$</td> <td>$0.03 < W \leq 0.05$</td> <td>3</td> </tr> <tr> <td>$L \leq 2.5$</td> <td>$0.05 < W \leq 0.10$</td> <td>2</td> </tr> <tr> <td>/</td> <td>$0.1 < W$</td> <td></td> </tr> <tr> <td colspan="2">Total</td> <td>3</td> </tr> </tbody> </table> <p>Distance between 2 defects should more than 3mm apart. Scratches not viewable through the back of the display are acceptable.</p> | Length | Width | Acc. Qty | / | $W \leq 0.03$ | Ignore | $L \leq 2.5$ | $0.03 < W \leq 0.05$ | 3 | $L \leq 2.5$ | $0.05 < W \leq 0.10$ | 2 | / | $0.1 < W$ | | Total | | 3 |
|--------------|---|---|--------|-------|----------|---|---------------|--------|--------------|----------------------|---|--------------|----------------------|---|---|-----------|--|-------|--|---|
| Length | Width | Acc. Qty | | | | | | | | | | | | | | | | | | |
| / | $W \leq 0.03$ | Ignore | | | | | | | | | | | | | | | | | | |
| $L \leq 2.5$ | $0.03 < W \leq 0.05$ | 3 | | | | | | | | | | | | | | | | | | |
| $L \leq 2.5$ | $0.05 < W \leq 0.10$ | 2 | | | | | | | | | | | | | | | | | | |
| / | $0.1 < W$ | | | | | | | | | | | | | | | | | | | |
| Total | | 3 | | | | | | | | | | | | | | | | | | |
| 04 | <p>Glass Crack (Minor defect)</p> |  <p>Crack is potential to enlarge, any type is not allowed.</p> | | | | | | | | | | | | | | | | | | |

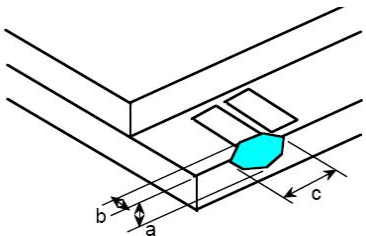
| 05 | <p>Glass Chipping Pad Area: (Minor defect)</p>  | <table border="1" data-bbox="869 1720 1340 1892"> <thead> <tr> <th>Length and Width</th> <th>Acc. Qty</th> </tr> </thead> <tbody> <tr> <td>$c > 3.0, b < 1.0$</td> <td>1</td> </tr> <tr> <td>$c < 3.0, b < 1.0$</td> <td>3</td> </tr> <tr> <td colspan="2">$a < \text{Glass Thickness}$</td> </tr> </tbody> </table> | Length and Width | Acc. Qty | $c > 3.0, b < 1.0$ | 1 | $c < 3.0, b < 1.0$ | 3 | $a < \text{Glass Thickness}$ | |
|------------------------------|--|--|------------------|----------|--------------------|---|--------------------|---|------------------------------|--|
| Length and Width | Acc. Qty | | | | | | | | | |
| $c > 3.0, b < 1.0$ | 1 | | | | | | | | | |
| $c < 3.0, b < 1.0$ | 3 | | | | | | | | | |
| $a < \text{Glass Thickness}$ | | | | | | | | | | |

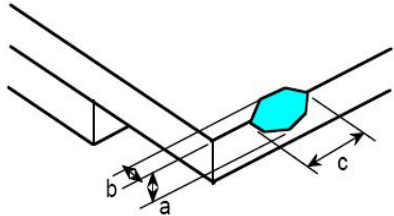
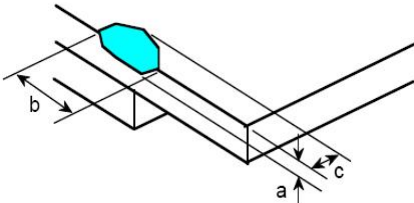
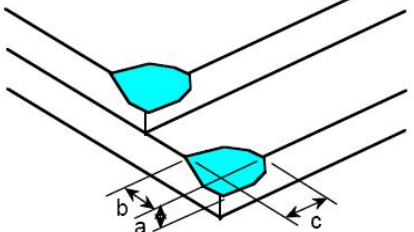
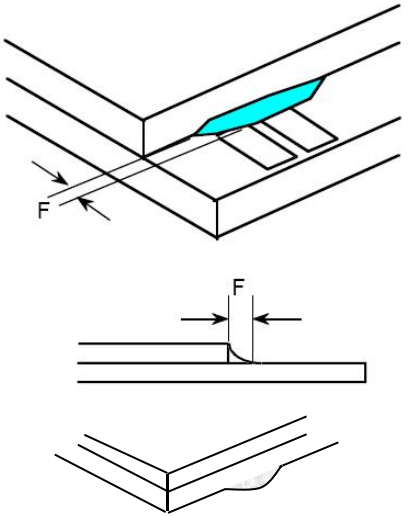
| 06 | <p>Glass Chipping Rear of Pad Area: (Minor defect)</p>  | <table border="1"> <thead> <tr> <th>Length and Width</th> <th>Acc. Qty</th> </tr> </thead> <tbody> <tr> <td>$c > 3.0, b < 1.0$</td> <td>1</td> </tr> <tr> <td>$c < 3.0, b < 1.0$</td> <td>2</td> </tr> <tr> <td>$c < 3.0, b < 0.5$</td> <td>4</td> </tr> <tr> <td colspan="2" style="text-align: center;">$a < \text{Glass Thickness}$</td> </tr> </tbody> </table> | Length and Width | Acc. Qty | $c > 3.0, b < 1.0$ | 1 | $c < 3.0, b < 1.0$ | 2 | $c < 3.0, b < 0.5$ | 4 | $a < \text{Glass Thickness}$ | |
|------------------------------|--|--|------------------|----------|--------------------|--------|------------------------------|---|--------------------|---|------------------------------|--|
| Length and Width | Acc. Qty | | | | | | | | | | | |
| $c > 3.0, b < 1.0$ | 1 | | | | | | | | | | | |
| $c < 3.0, b < 1.0$ | 2 | | | | | | | | | | | |
| $c < 3.0, b < 0.5$ | 4 | | | | | | | | | | | |
| $a < \text{Glass Thickness}$ | | | | | | | | | | | | |
| 07 | <p>Glass Chipping Except Pad Area: (Minor defect)</p>  | <table border="1"> <thead> <tr> <th>Length and Width</th> <th>Acc. Qty</th> </tr> </thead> <tbody> <tr> <td>$c > 3.0, b < 1.0$</td> <td>1</td> </tr> <tr> <td>$c < 3.0, b < 1.0$</td> <td>2</td> </tr> <tr> <td>$c < 3.0, b < 0.5$</td> <td>4</td> </tr> <tr> <td colspan="2" style="text-align: center;">$a < \text{Glass Thickness}$</td> </tr> </tbody> </table> | Length and Width | Acc. Qty | $c > 3.0, b < 1.0$ | 1 | $c < 3.0, b < 1.0$ | 2 | $c < 3.0, b < 0.5$ | 4 | $a < \text{Glass Thickness}$ | |
| Length and Width | Acc. Qty | | | | | | | | | | | |
| $c > 3.0, b < 1.0$ | 1 | | | | | | | | | | | |
| $c < 3.0, b < 1.0$ | 2 | | | | | | | | | | | |
| $c < 3.0, b < 0.5$ | 4 | | | | | | | | | | | |
| $a < \text{Glass Thickness}$ | | | | | | | | | | | | |
| 08 | <p>Glass Corner Chipping: (Minor defect)</p>  | <table border="1"> <thead> <tr> <th>Length and Width</th> <th>Acc. Qty</th> </tr> </thead> <tbody> <tr> <td>$c < 3.0, b < 3.0$</td> <td>Ignore</td> </tr> <tr> <td colspan="2" style="text-align: center;">$a < \text{Glass Thickness}$</td> </tr> </tbody> </table> | Length and Width | Acc. Qty | $c < 3.0, b < 3.0$ | Ignore | $a < \text{Glass Thickness}$ | | | | | |
| Length and Width | Acc. Qty | | | | | | | | | | | |
| $c < 3.0, b < 3.0$ | Ignore | | | | | | | | | | | |
| $a < \text{Glass Thickness}$ | | | | | | | | | | | | |
| 09 | <p>Glass Burr: (Minor defect)</p>  | <table border="1"> <thead> <tr> <th>Length</th> <th>Acc. Qty</th> </tr> </thead> <tbody> <tr> <td>$F < 1.0$</td> <td>Ignore</td> </tr> </tbody> </table> <p>Glass burr don't affect assemble and module dimension.</p> | Length | Acc. Qty | $F < 1.0$ | Ignore | | | | | | |
| Length | Acc. Qty | | | | | | | | | | | |
| $F < 1.0$ | Ignore | | | | | | | | | | | |

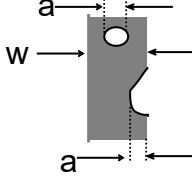
| 10 | <p>FPC Defect: (Minor defect)</p>  | <p>10.1 Dent, pinhole width $a < w/3$. (w: circuitry width.) 10.2 Open circuit is unacceptable. 10.3 No oxidation, contamination and distortion.</p> | | | | | | | | | | |
|----------------------------|---|---|----------|----------|---------------------|--------|----------------------------|---|----------------------------|---|------------------|------|
| 11 | Bubble on Polarizer (Minor defect) | <table border="1" data-bbox="743 577 1214 790"> <thead> <tr> <th>Diameter</th> <th>Acc. Qty</th> </tr> </thead> <tbody> <tr> <td>$\varphi \leq 0.20$</td> <td>Ignore</td> </tr> <tr> <td>$0.20 < \varphi \leq 0.30$</td> <td>4</td> </tr> <tr> <td>$0.30 < \varphi \leq 0.50$</td> <td>1</td> </tr> <tr> <td>$0.50 < \varphi$</td> <td>None</td> </tr> </tbody> </table> | Diameter | Acc. Qty | $\varphi \leq 0.20$ | Ignore | $0.20 < \varphi \leq 0.30$ | 4 | $0.30 < \varphi \leq 0.50$ | 1 | $0.50 < \varphi$ | None |
| Diameter | Acc. Qty | | | | | | | | | | | |
| $\varphi \leq 0.20$ | Ignore | | | | | | | | | | | |
| $0.20 < \varphi \leq 0.30$ | 4 | | | | | | | | | | | |
| $0.30 < \varphi \leq 0.50$ | 1 | | | | | | | | | | | |
| $0.50 < \varphi$ | None | | | | | | | | | | | |
| 12 | Dent on Polarizer (Minor defect) | <table border="1" data-bbox="743 840 1214 1052"> <thead> <tr> <th>Diameter</th> <th>Acc. Qty</th> </tr> </thead> <tbody> <tr> <td>$\varphi \leq 0.20$</td> <td>Ignore</td> </tr> <tr> <td>$0.20 < \varphi \leq 0.30$</td> <td>4</td> </tr> <tr> <td>$0.30 < \varphi \leq 0.50$</td> <td>1</td> </tr> <tr> <td>$0.50 < \varphi$</td> <td>None</td> </tr> </tbody> </table> | Diameter | Acc. Qty | $\varphi \leq 0.20$ | Ignore | $0.20 < \varphi \leq 0.30$ | 4 | $0.30 < \varphi \leq 0.50$ | 1 | $0.50 < \varphi$ | None |
| Diameter | Acc. Qty | | | | | | | | | | | |
| $\varphi \leq 0.20$ | Ignore | | | | | | | | | | | |
| $0.20 < \varphi \leq 0.30$ | 4 | | | | | | | | | | | |
| $0.30 < \varphi \leq 0.50$ | 1 | | | | | | | | | | | |
| $0.50 < \varphi$ | None | | | | | | | | | | | |
| 13 | Bezel | <p>13.1 No rust, distortion on the Bezel. 13.2 No visible fingerprints, stains or other contamination.</p> | | | | | | | | | | |
| 14 | Touch Panel | <p>D: Diameter W: width L: length 14.1 Spot: $D < 0.25$ is acceptable $0.25 \leq D \leq 0.4$ 2dots are acceptable and the distance between defects should more than 10 mm. $D > 0.4$ is unacceptable 14.2 Dent: $D > 0.40$ is unacceptable 14.3 Scratch: $W \leq 0.03$, $L \leq 10$ is acceptable, $0.03 < W \leq 0.10$, $L \leq 10$ is acceptable Distance between 2 defects should more than 10 mm. $W > 0.10$ is unacceptable.</p> | | | | | | | | | | |
| 15 | PCB | <p>15.1 No distortion or contamination on PCB terminals. 15.2 All components on PCB must same as documented on the BOM/component layout. 15.3 Follow IPC-A-600F.</p> | | | | | | | | | | |
| 16 | Soldering | Follow IPC-A-610C standard | | | | | | | | | | |
| 17 | Electrical Defect (Major defect) | <p>The below defects must be rejected. 17.1 Missing vertical / horizontal segment, 17.2 Abnormal Display.</p> | | | | | | | | | | |

| | | |
|--|--|--|
| | | 17.3 No function or no display. 17.4 Current exceeds product specifications. 17.5 LCD viewing angle defect. 17.6 No Backlight. 17.7 Dark Backlight. 17.8 Touch Panel no function. |
|--|--|--|

Remark: LCD Panel Broken shall be rejected. Defect out of LCD viewing area is acceptable.

10.7. Classification of Defects

- 10.7.1. Visual defects (Except no / wrong label) are treated as minor defect and electrical defect is major.
- 10.7.2. Two minor defects are equal to one major in lot sampling inspection.

10.8. Identification/marketing criteria

Any unit with illegible / wrong /double or no marking/ label shall be rejected.

10.9. Packaging

- 10.9.1. There should be no damage of the outside carton box, each packaging box should have one identical label.
- 10.9.2. Modules inside package box should have compliant mark.
- 10.9.3. All direct package materials shall offer ESD protection

Note1: Bright dot is defined as the defective area of the dot is larger than 50% of one sub-pixel area.

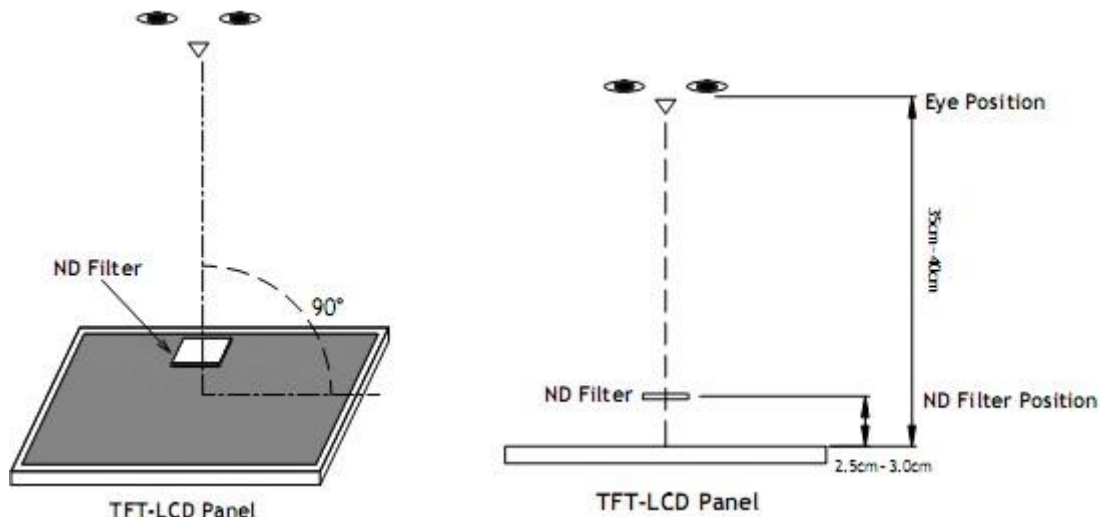

Bright dot: The bright dot size defect at black display pattern. It can be recognized by 2% transparency of filter when the distance between eyes and panel is $350\text{mm} \pm 50\text{mm}$.

Dark dot: Cyan, Magenta or Yellow dot size defect at white display pattern. It can be recognized by 5% transparency of filter when the distance between eyes and panel is $350\text{mm} \pm 50\text{mm}$.

Note2: Mura on display which appears darker / brighter against background brightness on parts of display area.

11. Reliability Specification

| No | Item | Condition | Quantity | Criteria |
|----|-----------------------------|---|----------|------------------|
| 1 | High Temperature Operating | 80°C, 96Hrs | 2 | GB/T2423.2-2008 |
| 2 | Low Temperature Operating | -30°C, 96Hrs | 2 | GB/T2423.1-2008 |
| 3 | High Humidity | 50°C, 90%RH, 96Hrs | 2 | GB/T2423.3-2006 |
| 4 | High Temperature Storage | 85°C, 96Hrs | 2 | GB/T2423.2-2008 |
| 5 | Low Temperature Storage | -30°C, 96Hrs | 2 | GB/T2423.1-2008 |
| 6 | Thermal Cycling Test | -30°C, 60min~80°C, 60min, 20 cycles. | 2 | GB/T2423.22-2012 |
| 7 | Packing vibration | Frequency range:10Hz~50Hz Acceleration of gravity:5G X, Y, Z 30 min for each direction. | 2 | GB/T5170.14-2009 |
| 8 | Electrical Static Discharge | Air: ±8KV 150pF/330 Ω 5 times | 2 | GB/T17626.2-2006 |
| | | Contact: ±4KV 150pF/330 Ω 5 times | | |
| 9 | Drop Test (Packaged) | Height:80 cm,1 corner, 3 edges, 6 surfaces. | 2 | GB/T2423.8-1995 |

Note1. No defection cosmetic and operational function allowable.

Note2. Total current Consumption should be below double of initial value.

12. Precautions and Warranty

12.1. Safety

- 12.1.1. The liquid crystal in the LCD is poisonous. Do not put it in your mouth. If the liquid crystal touches your skin or clothes, wash it off immediately using soap and water.
- 12.1.2. Since the liquid crystal cells are made of glass, do not apply strong impact on them. Handle with care.

12.2. Handling

- 12.2.1. Reverse and use within ratings in order to keep performance and prevent damage.
- 12.2.2. Do not wipe the polarizer with dry cloth, as it might cause scratch. If the surface of the LCD needs to be cleaned, wipe it swiftly with cotton or other soft cloth soaked with petroleum IPA, do not use other chemicals.

12.3. Storage

- 12.3.1. Do not store the LCD module beyond the specified temperature ranges.
- 12.3.2. Strong light exposure causes degradation of polarizer and color filter.

12.4. Metal Pin (Apply to Products with Metal Pins)

12.4.1. Pins of LCD and Backlight

12.4.1.1. Solder tip can touch and press on the tip of Pin LEAD during the soldering

12.4.1.2. Recommended Soldering Conditions

Solder Type: Sn96.3~94-Ag3.3~4.3-Cu0.4~1.1

Maximum Solder Temperature: 370°C

Maximum Solder Time: 3s at the maximum temperature

Recommended Soldering Temp: 350±20°C

Typical Soldering Time: ≤3s

12.4.1.3. Solder Wetting

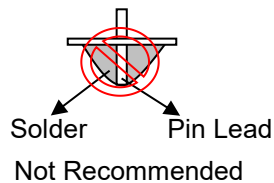
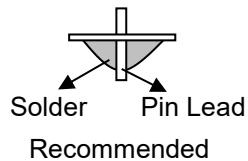

12.4.2. Pins of EL

12.4.2.1. Solder tip can touch and press on the tip of EL leads during soldering.

12.4.2.2. No Solder Paste on the soldering pad on the motherboard is recommended.

12.4.2.3. Recommended Soldering Conditions

Solder type: Nippon Alimit Leadfree SR-34, size 0.5mm

Recommended Solder Temperature: 270~290°C

Typical Soldering Time: ≤2s

Minimum solder distance from EL lamp (body): 2.0mm

12.4.2.4. No horizontal press on the EL leads during soldering.

12.4.2.5. 180° bend EL leads three times is not allowed.

12.4.2.6. Solder Wetting

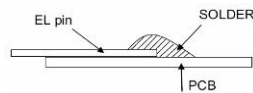

Recommended

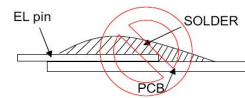

Not Recommended

12.4.2.7. The type of the solder iron:

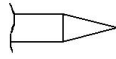

Recommended

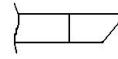

Not Recommended

12.4.2.8. Solder Pad

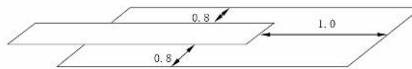

12.5. Operation

- 12.5.1. Do not drive LCD with DC voltage
- 12.5.2. Response time will increase below lower temperature
- 12.5.3. Display may change color with different temperature
- 12.5.4. Mechanical disturbance during operation, such as pressing on the display area, may cause the segments to appear "fractured".
- 12.5.5. Do not connect or disconnect the LCM to or from the system when power is on.
- 12.5.6. Never use the LCM under abnormal condition of high temperature and high humidity.
- 12.5.7. Module has high frequency circuits. Sufficient suppression to the electromagnetic interface shall be done by system manufacturers. Grounding and shielding methods may be important to minimize the interference.
- 12.5.8. Do not display the fixed pattern for long time (we suggest the time not longer than one hour) because it may develop image sticking due to the TFT structure.

12.6. Static Electricity

- 12.6.1. CMOS LSIs are equipped in this unit, so care must be taken to avoid the electro-static charge, by ground human body, etc.
- 12.6.2. The normal static prevention measures should be observed for work clothes and benches.
- 12.6.3. The module should be kept into anti-static bags or other containers resistant to static for storage.

12.7. Limited Warranty

- 12.7.1. Our warranty liability is limited to repair and/or replacement. We will not be responsible for any consequential loss.
- 12.7.2. If possible, we suggest customer to use up all modules in six months. If the module storage time over twelve months, we suggest that recheck it before the module be used
- 12.7.3. After the product shipped, any product quality issues must be feedback within three months, otherwise, we will not be responsible for the subsequent or consequential events.

13. Packaging

TBD

