



**SPECIFICATION
FOR
LCD MODULE**

Customer : _____
Product Model: XA070TN83 V.1
Sample code: _____

Designed by	Checked by	Approved by

Final Approval by Customer

<input type="checkbox"/> LCM Machinery OK Checked By _____ <input type="checkbox"/> LCM Display OK Checked By _____	<input type="checkbox"/> LCM OK <input type="checkbox"/> NG , Problem survey: Approved By _____
--	---

※The specification of "TBD" should refer to the measured value of sample . If there is difference between the design specification and measured value, we naturally shall negotiate and agree to solution with customer.

Record of Revision

Version	Revise Date	Page	Content
V01	2021/ 09/ 25		Initial release.

Contents

1. General Specifications	1
2. Pin Assignment	2
3. Operation Specifications	5
3.1. Absolute Maximum Ratings	5
3.2. Typical Operation Conditions	6
3.3. Power Sequence	7
3.4. Timing Characteristics	8
3.4.1. Timing Conditions	8
3.4.2. Timing Diagram	9
4. Optical Specifications	11
5. Reliability Test Items	15
6. General Precautions	16
6.1. Safety	16
6.2. Handling	16
6.3. Static Electricity	16
6.4. Storage	16
6.5. Cleaning	16
7. Mechanical Drawing	17
8. Package Drawing	18

1. General Specifications

No.	Item	Specification	Remark
1	LCD size	7.0 inch(Diagonal)	
2	Driver element	a-Si TFT active matrix	
3	Resolution	800X3(RGB)X480	
4	Display mode	Normally Black	
5	Dot pitch	0.0635(W)X0.1905(H) mm	
6	Active area	152.4 (W)X91.44 (H) mm	
7	Module size	165(W)X104.09(H)X5.3 (D) mm	Note 1
8	Surface treatment	Anti-Glare	
9	Color arrangement	RGB-stripe	
10	Interface	Digital (TTL)	
11	Backlight power consumption	2.5W (Typ.)	Note 2
12	Panel power consumption	0.66 W (Typ.)	Note 3
13	Weight	T.B.D.	

Note 1: Refer to Mechanical Drawing.

Note 2: Including LED Driver power consumption.

Note 3: Including T-con Board power consumption.

2. Pin Assignment

TTL Connector is used for the module electronic interface. The recommended model is “FH33-40S-0.5SH(10)”, manufactured by Hirose.

Pin No.	Symbol	I/O	Function	Remark
1	V _{LED}	P	Power supply for LED Driver	
2	V _{LED}	P	Power supply for LED Driver	
3	ADJ	I	Adjust the led brightness with PWM Pulse	Note 1,2
4	G _{LED}	P	Ground for LED circuit	
5	G _{LED}	P	Ground for LED circuit	
6	V _{CC}	P	Power supply for digital circuit	
7	V _{CC}	P	Power supply for digital circuit	
8	MODE	I	DE or HV mode control	Note 3
9	DE	I	Data enable	
10	VS	I	Vsync signal input	
11	HS	I	Hsync signal input	
12	GND	P	Power ground	
13	B5	I	Blue data input (MSB)	
14	B4	I	Blue data input	
15	B3	I	Blue data input	
16	GND	P	Power ground	
17	B2	I	Blue data input	
18	B1	I	Blue data input	
19	B0	I	Blue data input(LSB)	
20	GND	P	Power ground	
21	G5	I	Green data input(MSB)	
22	G4	I	Green data input	
23	G3	I	Green data input	
24	GND	P	Power ground	
25	G2	I	Green data input	
26	G1	I	Green data input	

27	G0	I	Green data input(LSB)	
28	GND	P	Power ground	
29	R5	I	Red data input(MSB)	
30	R4	I	Red data input	
31	R3	I	Red data input	
32	GND	P	Power ground	
33	R2	I	Red data input	
34	R1	I	Red data input	
35	R0	I	Red data input(LSB)	
36	GND	P	Power ground	
37	DCLK	I	Sample clock	
38	GND	P	Power ground	
39	L/R	I	Select left or right scanning direction	Note 4,5
40	U/D	I	Select up or down scanning direction	Note 4,5

Note1: Pin3. is used to adjust brightness.

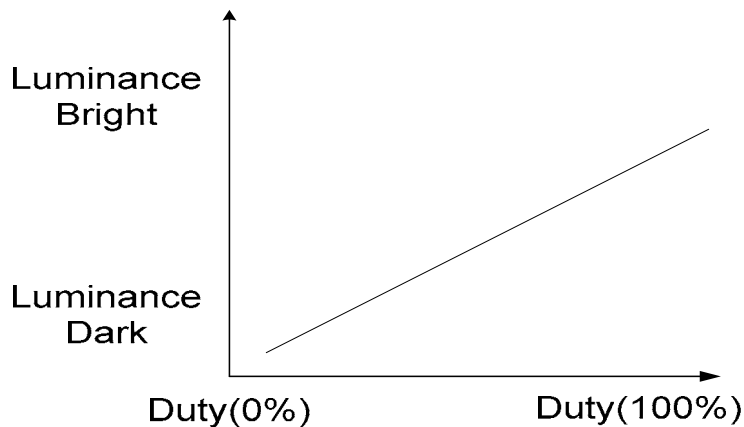

Note 2: ADJ signal=0 ~3.3V; Operating frequency:100 Hz ~ 25K Hz.

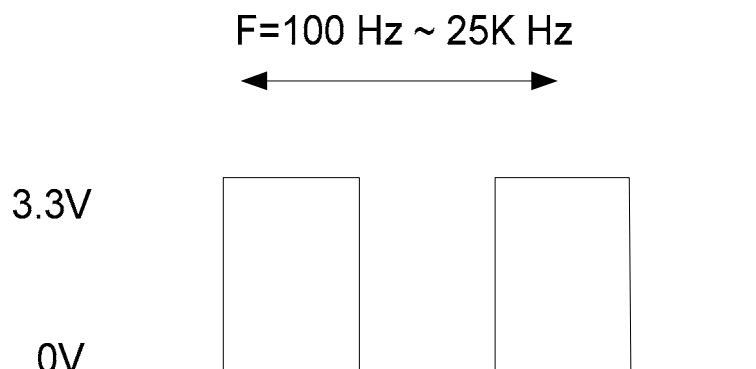

Note 3: DE Mode: Mode="H",HS floating and VS floating.
 HV Mode: Mode="L" and DE floating.

Note 4: Selection of scanning mode

Setting of scan control input		Scanning direction
U/D	L/R	
GND	V _{CC}	Up to down, left to right
V _{CC}	GND	Down to up, right to left
GND	GND	Up to down, right to left
V _{CC}	V _{CC}	Down to up, left to right

Note 5: Scanning direction refer to the figure below.

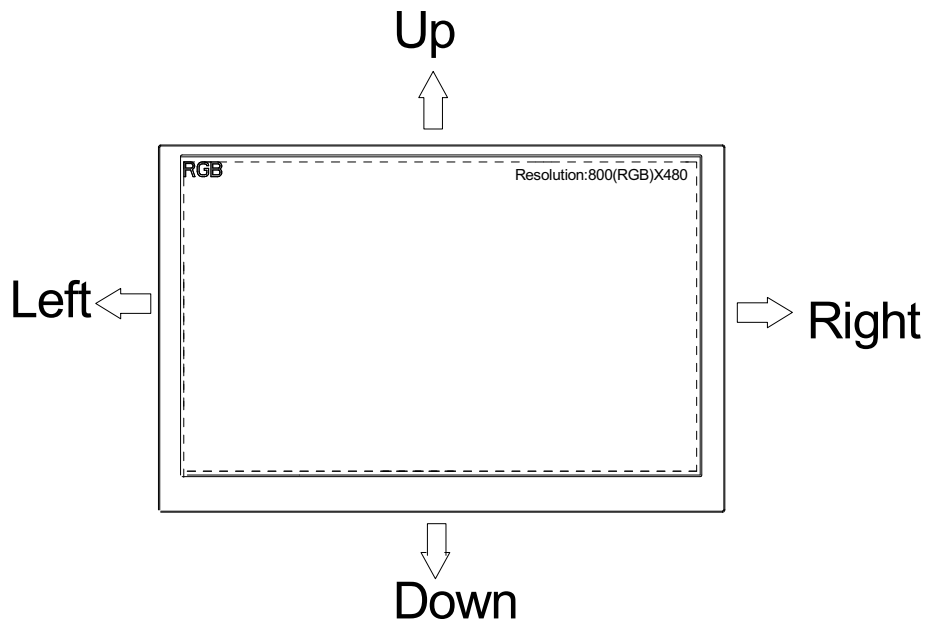

3. Operation Specifications

3.1. Absolute Maximum Ratings

Item	Symbol	Values		Unit	Remark
		Min.	Max.		
Power voltage	V_{CC}	-0.3	6.0	V	
	V_{LED}	-	5.5	V	
Input signal voltage	V_I	-0.3	6.3	V	
Operation Temperature	T_{OP}	-20	70	°C	
Storage Temperature	T_{ST}	-30	80	°C	

Note: The absolute maximum rating values of this product are not allowed to be exceeded at any times. A module should be used with any of the absolute maximum ratings exceeded, the characteristics of the module may not be recovered, or in an extreme condition, the module may be permanently destroyed.

3.2. Typical Operation Conditions

Item	Symbol	Values			Unit	Remark
		Min.	Typ.	Max.		
Power voltage	V_{CC}	3.1	3.3	3.5	V	Note 1
	V_{LED}	4.8	5.0	5.2	V	Note 2
Current consumption	I_{CC}	-	250	300	mA	
	I_{LED}	-	500	550	mA	Note 3
Input logic high voltage	V_{IH}	$0.7V_{CC}$	-	V	V	Note 4
Input logic low voltage	V_{IL}	0	-	0.3V	V	
LED life time	-	20,000	-	-	Hr	Note 5

Note1: V_{CC} setting should match the signals output voltage (refer to Note 4) of customer's system board.

Note 2: LED driving voltage.

Note 3: LED driving current.

Note 4: DCLK,DE, HS, VS, R0~ R5,,G0~ G5,B0~ B5.

Note 5: The "LED life time" is defined as the module brightness decrease to 50% original brightness at $T_a=25$ and $V_{LED}=5.0V$. The LED lifetime could be decreased if operating V_{LED} is larger than 5.0V.

3.3. Power Sequence

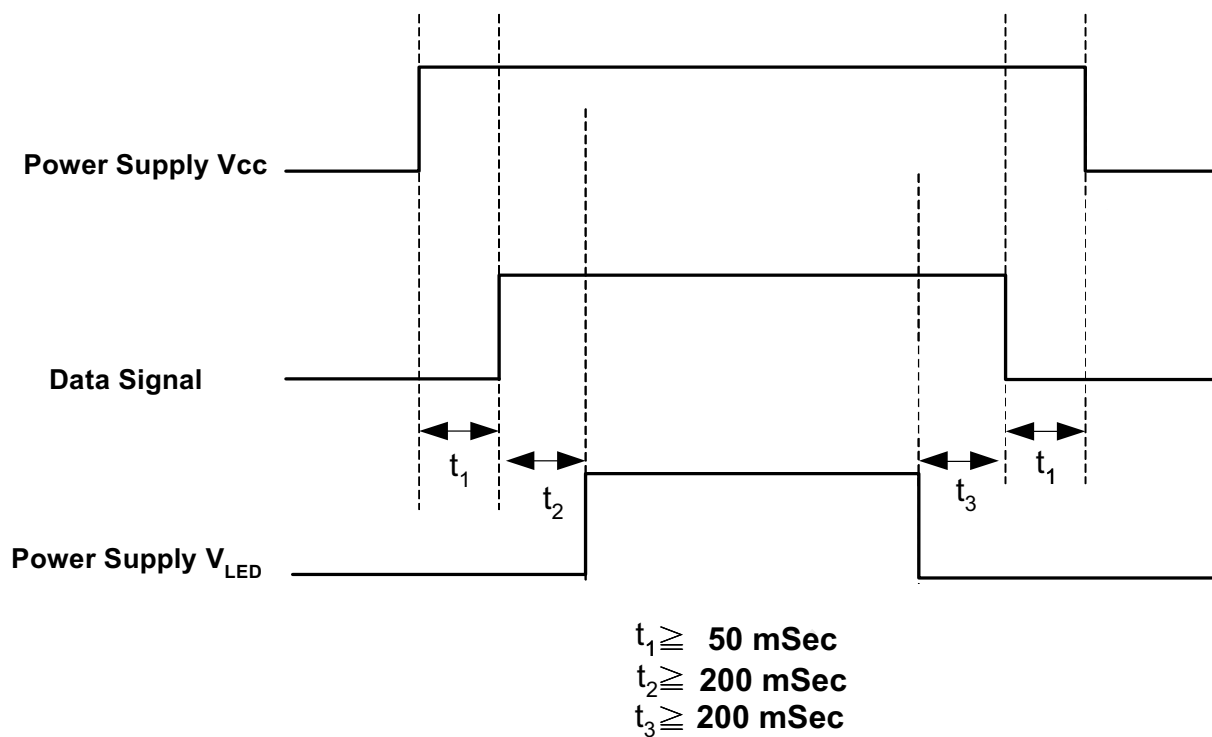

Note: Data Signal includes DCLK, DE, HS, VS, R0~ R5, G0~ G5, B0~ B5.

3.4. Timing Characteristics

3.4.1. Timing Conditions

Item	Symbol	Min	Typ	Max	Unit	Remark
Clock frequency	F_{CLK}	27.027	29.988	40.0	MHz	
Vertical display area	T_{VD}	480			H	
Vertical period area	T_V	525	525	530	H	
Vertical blanking area	T_{VB}	45	45	50	H	Note1
Vertical pulse width	T_{VPW}	3			H	
Vertical back porch	T_{VBP}	20			H	
Vertical front porch	T_{VFP}	25	25	30	H	
Horizontal display area	T_{HD}	800			dclk	
Horizontal period area	T_H	858	952	1258	dclk	
Horizontal blanking area	T_{HB}	58	152	458	dclk	Note2
Horizontal pulse width	T_{HPW}	3			dclk	
Horizontal back porch	T_{HBP}	48			dclk	
Horizontal front porch	T_{HFP}	10	104	410	dclk	
HS setup time	T_{HSU}	6	-	-	ns	
HS hold time	T_{HHD}	6	-	-	ns	
VS setup time	T_{VSU}	6	-	-	ns	
VS hold time	T_{VHD}	6	-	-	ns	
Data setup time	T_{DSU}	6	-	-	ns	
Data hold time	T_{DHU}	6	-	-	ns	
DE setup time	T_{ESU}	6	-	-	ns	

Note1: $T_{VB} = T_V - T_{VD}$

Note2: $T_{HB} = T_H - T_{HD}$

3.4.2. Timing Diagram

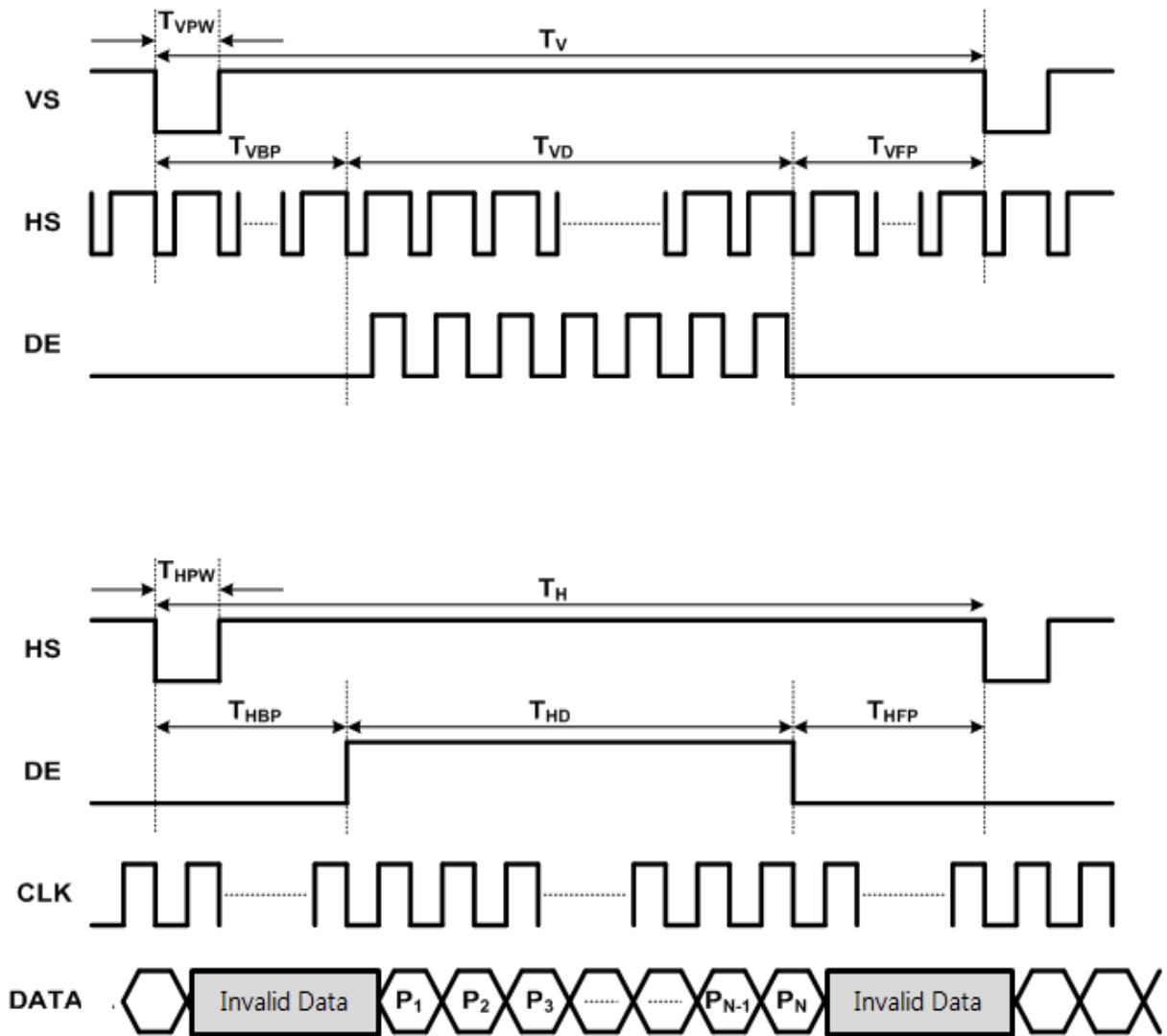

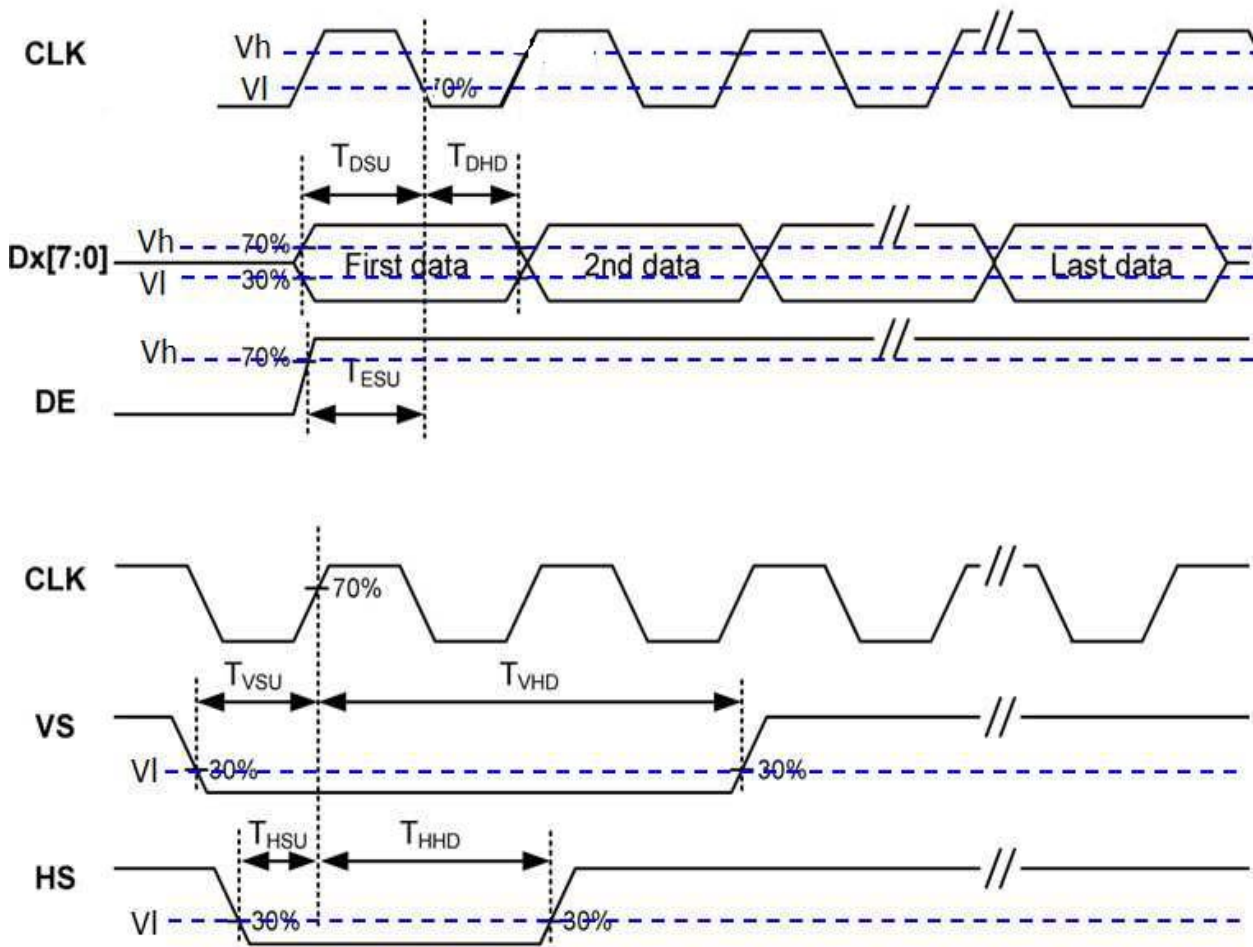

Note : Latch data at CLK falling edge.

4. Optical Specifications

Item	Symbol	Condition	Values			Unit	Remark
			Min.	Typ.	Max.		
Viewing angle (CR≥ 10)	θ_L	$\Phi=180^\circ$ (9 o'clock)	70	80	-	degree	Note 1
	θ_R	$\Phi=0^\circ$ (3 o'clock)	70	80	-		
	θ_T	$\Phi=90^\circ$ (12 o'clock)	70	80	-		
	θ_B	$\Phi=270^\circ$ (6 o'clock)	70	80	-		
Response time	T_{ON}	Normal $\theta=\Phi=0^\circ$	-	11	-	msec	Note 3
	T_{OFF}		-	9	-	msec	Note 3
Contrast ratio	CR		800	1000	-	-	Note 4
Color chromaticity	W_X		0.270	0.0290	0.350		Note 2 Note 5
	W_Y		0.280	0.0300	0.360		Note 6
Luminance	L		-	350	-	cd/m ²	Note 6
Luminance uniformity	Y_U		70	75	-	%	Note 7

Test Conditions:

1. $V_{CC}=3.3V$, $V_{LED}=5.0V$.The ambient temperature is $25^\circ C$.
2. The test systems refer to Note 2.

Note 1: Definition of viewing angle

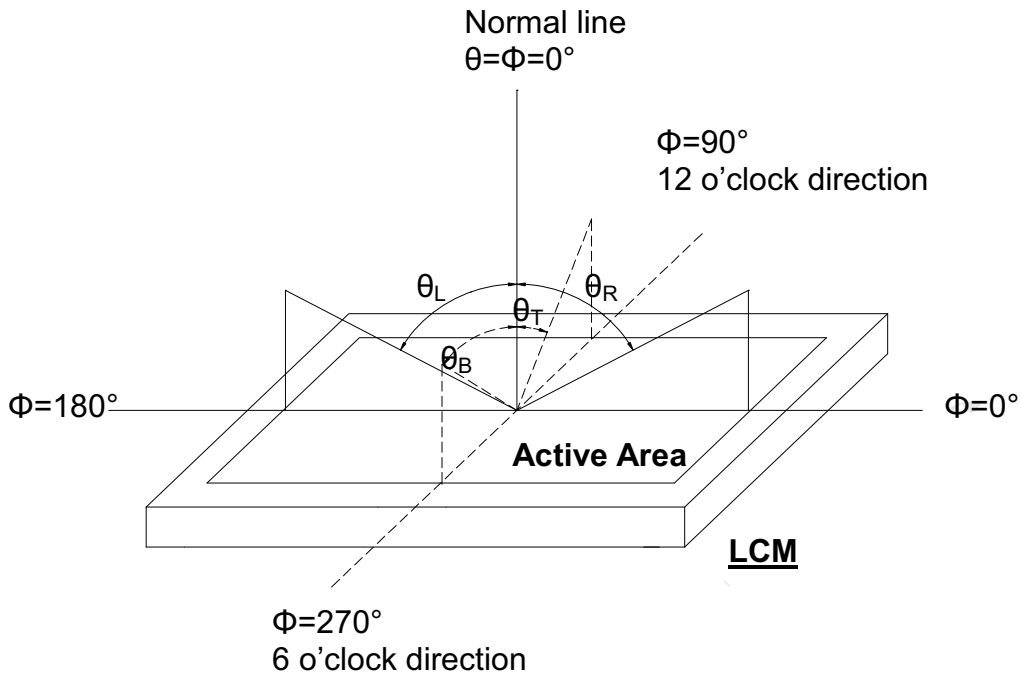

Fig. 4-1 Definition of viewing angle

Note 2: Definition of optical measurement system.

The optical characteristics should be measured in dark room. After 30 minutes operation, the optical properties are measured at the center point of the LCD screen. (Response time is measured by Photo detector TOPCON BM-7, other items are measured by BM-5A/Field of view: 1° /Height: 500mm.)

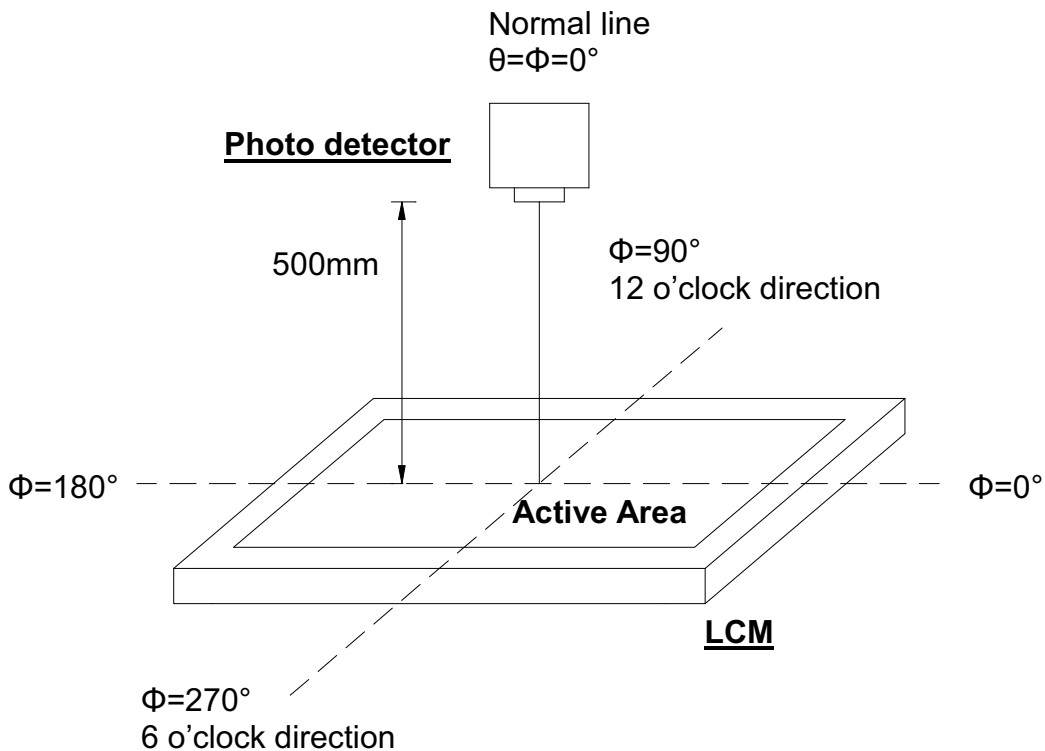

Fig. 4-2 Optical measurement system setup

Note 3: Definition of Response time

The response time is defined as the LCD optical switching time interval between "White" state and "Black" state. Rise time (T_{ON}) is the time between photo detector output intensity changed from 90% to 10%. And fall time (T_{OFF}) is the time between photo detector output intensity changed from 10% to 90%.

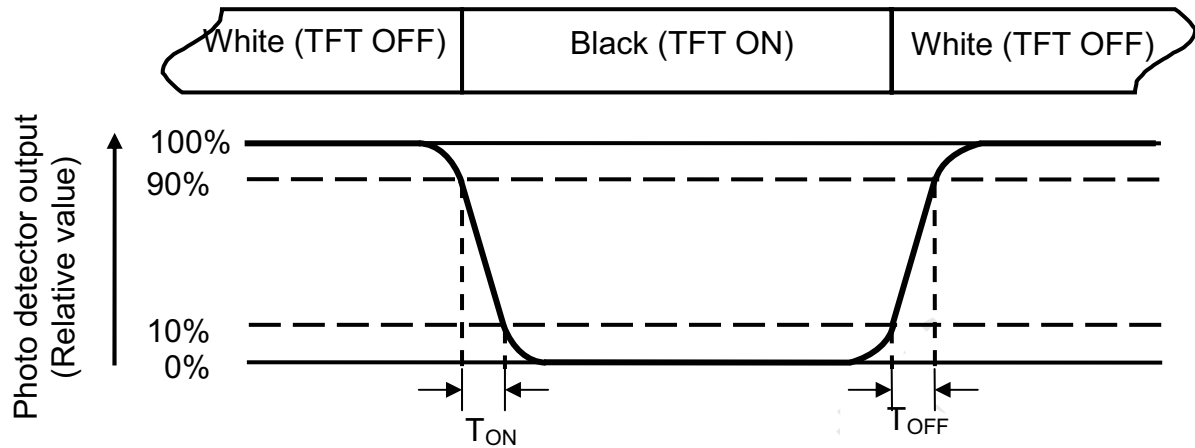

Fig. 4-3 Definition of response time

Note 4: Definition of contrast ratio

$$\text{Contrast ratio (CR)} = \frac{\text{Luminance measured when LCD on the "White" state}}{\text{Luminance measured when LCD on the "Black" state}}$$

Note 5: Definition of color chromaticity (CIE1931)

Color coordinates measured at center point of LCD.

Note 6: All input terminals LCD panel must be ground while measuring the center area of the panel. The LED driving condition is $V_{LED}=5.0V$.

Note 7: Definition of Luminance Uniformity

Active area is divided into 9 measuring areas (Refer to Fig. 4-4).Every measuring point is placed at the center of each measuring area.

$$\text{Luminance Uniformity (Yu)} = \frac{B_{min}}{B_{max}}$$

L-----Active area length W----- Active area width

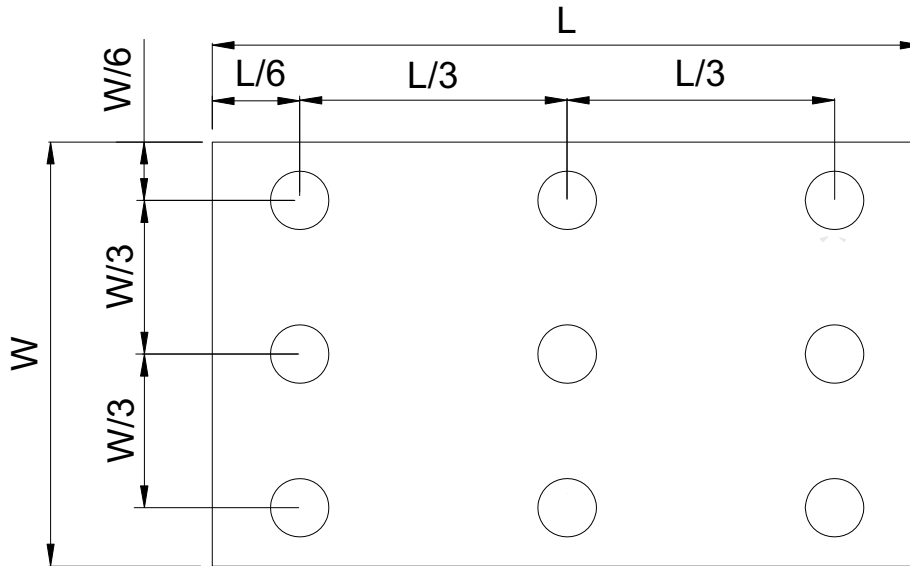

Fig. 4-4 Definition of measuring points

B_{max}: The measured maximum luminance of all measurement position.

B_{min}: The measured minimum luminance of all measurement position.

6. General Precautions

6.1. Safety

Liquid crystal is poisonous. Do not put it in your mouth. If liquid crystal touches your skin or clothes, wash it off immediately by using soap and water.

6.2. Handling

1. The LCD panel is plate glass. Do not subject the panel to mechanical shock or to excessive force on its surface.
2. The polarizer attached to the display is easily damaged. Please handle it carefully to avoid scratch or other damages.
3. To avoid contamination on the display surface, do not touch the module surface with bare hands.
4. Keep a space so that the LCD panels do not touch other components.
5. Put cover board such as acrylic board on the surface of LCD panel to protect panel from damages.
6. Transparent electrodes may be disconnected if you use the LCD panel under environmental conditions where the condensation of dew occurs.
7. Do not leave module in direct sunlight to avoid malfunction of the ICs.

6.3. Static Electricity

1. Be sure to ground module before turning on power or operating module.
2. Do not apply voltage which exceeds the absolute maximum rating value.

6.4. Storage

1. Store the module in a dark room where must keep at $25\pm 10^{\circ}\text{C}$ and 65%RH or less.
2. Do not store the module in surroundings containing organic solvent or corrosive gas.
3. Store the module in an anti-electrostatic container or bag.

6.5. Cleaning

1. Do not wipe the polarizer with dry cloth. It might cause scratch.
2. Only use a soft sloth with IPA to wipe the polarizer, other chemicals might permanent damage to the polarizer.

7. Mechanical Drawing

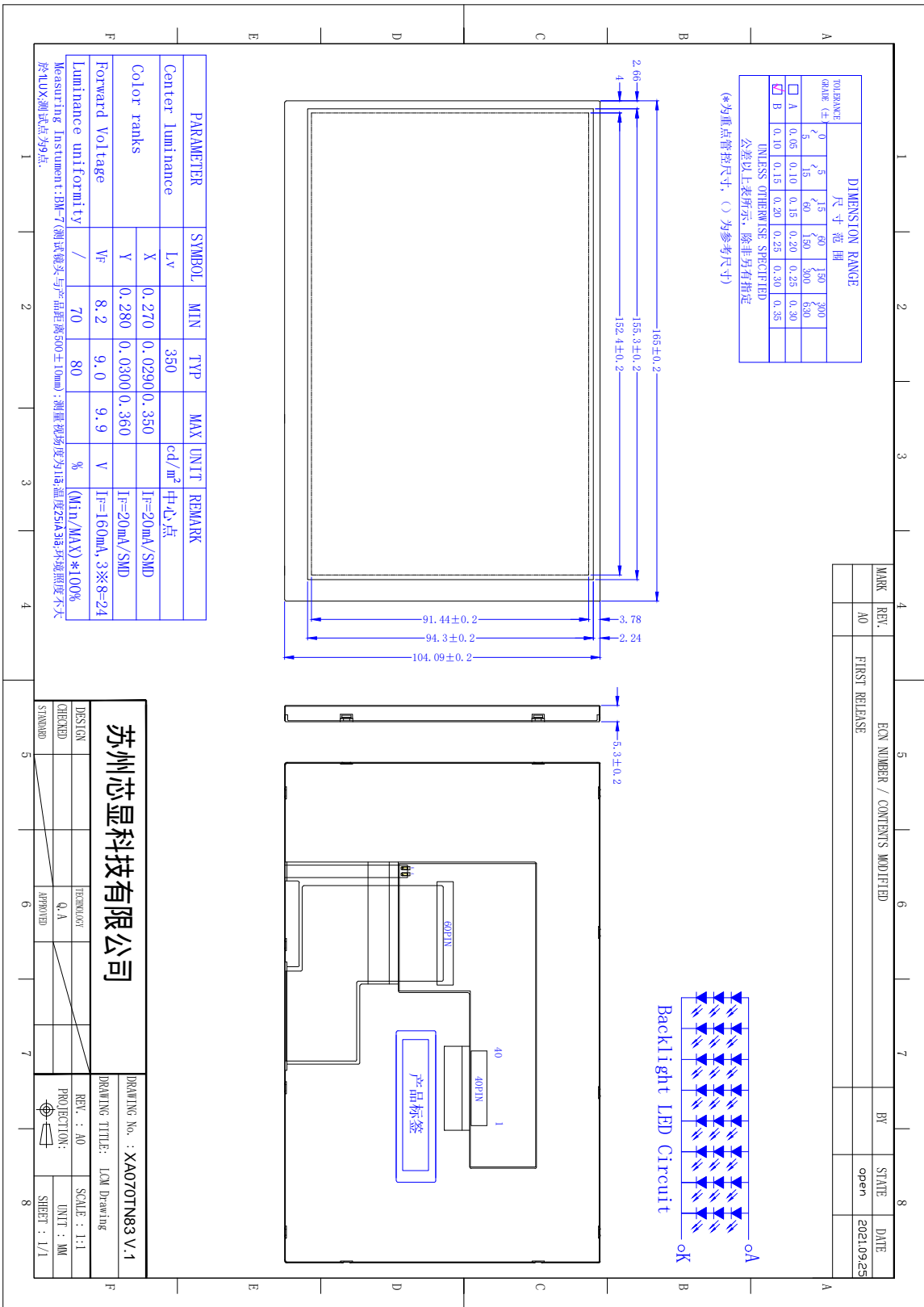

8. Package Drawing

T.B.D.