



PRODUCT SPECIFICATION

- Tentative Specification
- Preliminary Specification
- Approval Specification

MODELNAME:XB050VA40-R01

Version:RA01

Customer: Common	
APPROVED BY	SIGNATURE
Name / Title _____	_____
Note	

Please return 1 copy for your confirmation with your signature and comments.	

Approved By	Checked By	Prepared By

Revision Record**修订记录**

Rev. No.	Date	Description 描述
V01	2022-03-10	Preliminary Specification Release. 初步规格发布

Contents

内容

1. General Specifications	1
总体规格	
2. Mechanical Drawing	2
机械图纸	
3. Pin Assignments	3
引脚分配	
4. Electrical Specification	4
电子规格	
4.1. DC Characteristics	4
直流特性	
4.2. Typical Operation Conditions	4
平常运行条件	
4.3. Backlight Circuit Characteristics	5
背光线路特性	
4.4. Power on/off Sequence	6
上下电顺序	
4.5. Timing for RGB Interface	7
RGB 接口时序	
4.6. Parallel 24 bit RGB Input Timing Table	8
并行 24 位 RGB 输入时序	
4.7. Electro-Optical Characteristics	9
光电特性	
5. Measurement System	10
检测系统	
5.1. LCM Viewing Angle	10
LCM 观看角度	
5.2. Response Time	10
反应时间	
5.3. Contrast Ratio (CR)	10
对比度	
6. Reliability Test Items	11
可靠性测试项目	
7. Suggestions for Using LCD Modules	13
使用 LCD 模块的建议	
8. Storage Method	16
储存方法	

1. General Specifications

Item 项目	Contents 内容	Unit 单位
Size 尺寸	5.0'TFT	inch 英尺
LCM Dimension LCM 尺寸	120.7(W)*75.8(H)*3.00(D)	mm
LCD Active Area LCD 显示区域	108.0*64.8	mm
Number of Dots 点数	800*RGB*480	pixel 像素
LCD Type LCD 种类	a-Si TFT	
Viewing Direction 观看方向	ALL O'CLOCK	
Driver IC IC 驱动	ST7262	
Interface Type 接口类型	RGB	
Operating Temperature 运行温度	-20°C~70°C	
Storage Temperature 储存温度	-30°C~80°C	
Backlight Type 背光源类型	12 LEDs	
Weight 重量	TBD	g

2. Mechanical Drawing

机械图纸

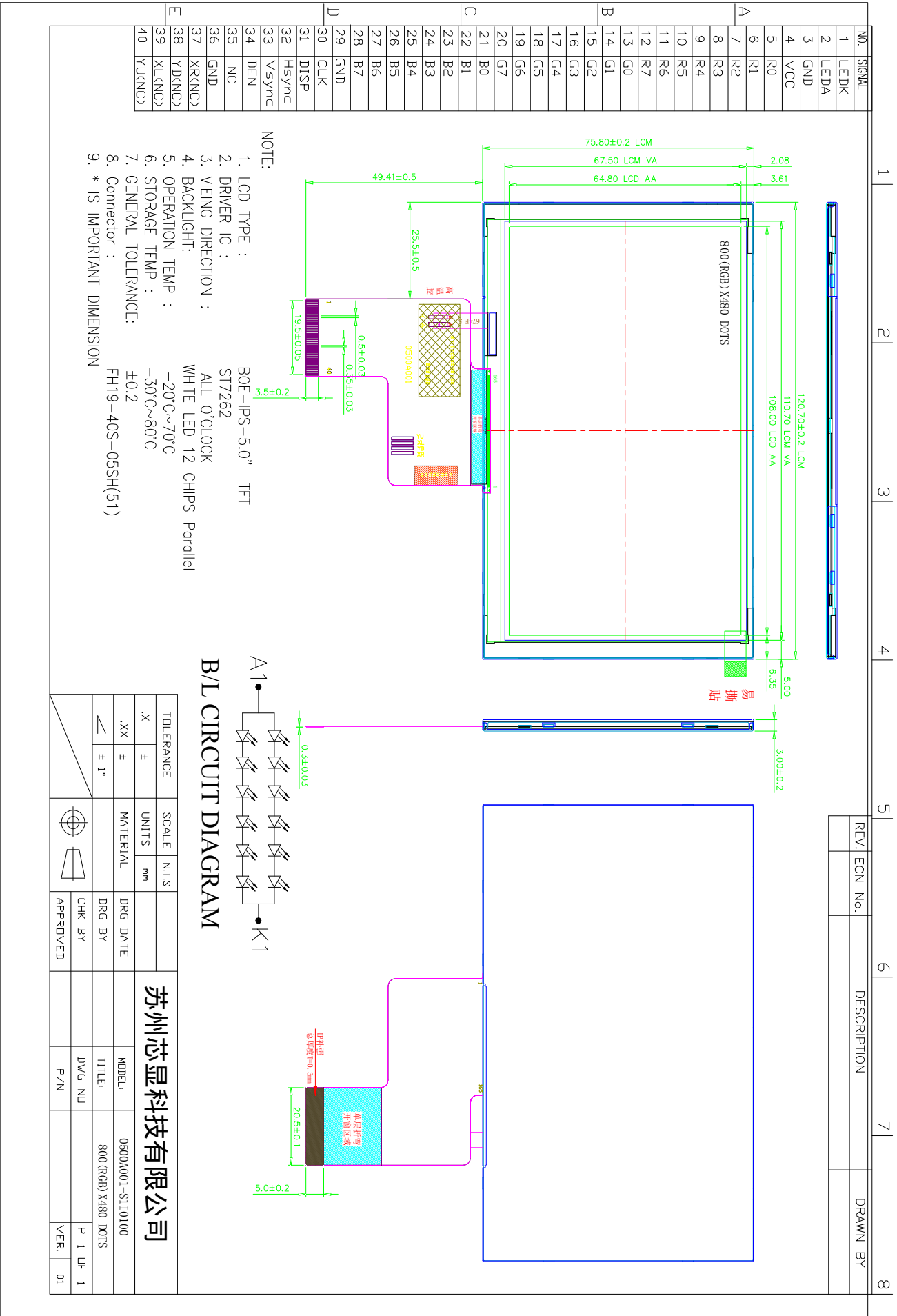

3. Pin Assignments

引脚分配

Pin No.	Symbol	Description
1	LEDK	LED BACKLIGHT(CATHODE)背光负极
2	LEDA	LED BACKLIGHT(ANODE)背光正极
3	GND	GROUND 接地
4	VCC	POWER SUPPLY 电源
5	R0	RED DATA 红色信号
6	R1	RED DATA 红色信号
7	R2	RED DATA 红色信号
8	R3	RED DATA 红色信号
9	R4	RED DATA 红色信号
10	R5	RED DATA 红色信号
11	R6	RED DATA 红色信号
12	R7	RED DATA 红色信号
13	G0	GREEN DATA 绿色信号
14	G1	GREEN DATA 绿色信号
15	G2	GREEN DATA 绿色信号
16	G3	GREEN DATA 绿色信号
17	G4	GREEN DATA 绿色信号
18	G5	GREEN DATA 绿色信号
19	G6	GREEN DATA 绿色信号
20	G7	GREEN DATA 绿色信号
21	B0	BLUE DATA 蓝色信号
22	B1	BLUE DATA 蓝色信号
23	B2	BLUE DATA 蓝色信号
24	B3	BLUE DATA 蓝色信号
25	B4	BLUE DATA 蓝色信号
26	B5	BLUE DATA 蓝色信号
27	B6	BLUE DATA 蓝色信号
28	B7	BLUE DATA 蓝色信号
29	GND	GROUND 接地
30	PCLK	CLOCK SIGNAL RGB 时钟信号
31	NC	NC
32	HS	HORIZONTAL SYNC INPUT IN RGB MODE 水平同步信号
33	VS	VERTICAL SYNC INPUT IN RGB MODE 垂直同步信号
34	DE	DATA ENABLE 数据使能
35	NC	NC
36	GND	GROUND 接地
37	XR(NC)	TOUCH PLANE PIN/NC 触摸脚
38	YD(NC)	TOUCH PLANE PIN/NC 触摸脚
39	XL(NC)	TOUCH PLANE PIN/NC 触摸脚
40	YU(NC)	TOUCH PLANE PIN/NC 触摸脚

4. Electrical Specification

4.1. DC Characteristics

DC 特性

Item	Symbol	Min	Typ.	Max	Unit
TFT gate on voltage TFT 栅极导通电压	VGH	--	12	--	V
TFT gate off voltage TFT 栅极不通电压	VGL	--	-12	--	V
TFT common electrode Voltage TFT 公共电极电压	Vcom	--	--	--	V

4.2. Typical Operation Conditions

平常运行条件

Item	Symbol	Min.	Typ.	Max.	Unit
Analog Supply Voltage 模拟电源电压	VCI	--	3.3	--	V
Digital Supply Voltage 数字电源电压	VDD	--	3.3	--	V
I/O Supply Voltage I/O 电源电压	IOVCC	--	1.8	3.3	V
Input High Voltage 输入高电压	VIH	0.8*IOVCC	-	IOVCC	V
Input Low Voltage 输入低电压	VIL	0	-	0.2*IOVCC	V
Output High Voltage 输出高电压	VOH	0.8*IOVCC	-	-	V
Output Low Voltage 输出低电压	VOL	-	-	0.2*IOVCC	V

4.3. Backlight Circuit Characteristics

背光源线路特性

Item 项目	Symbol 标志	Min.	Typ.	Max.	Unit
LED Current 电流 LED	IB	--	60	--	mA
LED Voltage 电压 LED	Vf	16.8	18.0	19.2	V
Brightness 亮度 of LCM LCM	L	430	500		cd/m2

4.4. Power on/off Sequence

上下电顺序

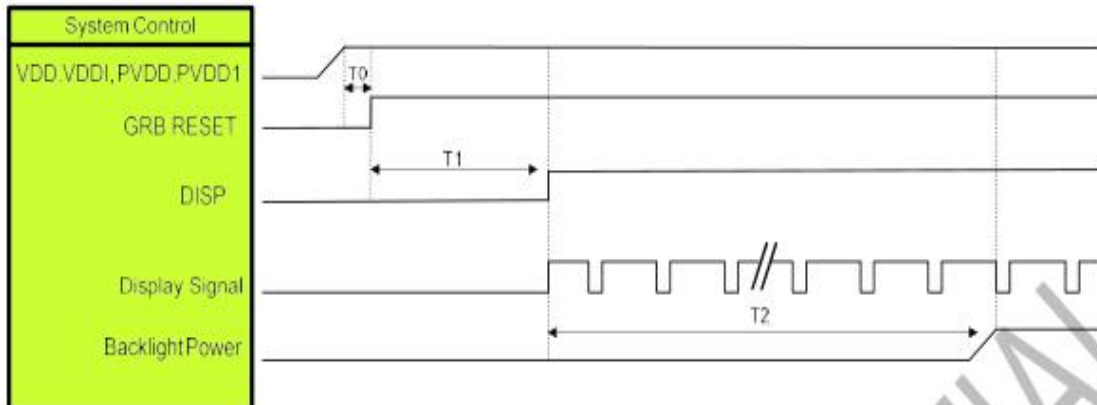

Symbol	Description	Min. Time	Unit
T0	System power stability to GRB RESET signal	0	ms
T1	GRB RESET= "High" to DISP="High"	10	ms
T2	Display Signal output to Backlight Power on	250	ms

Note: RGB interface Display signal: DCLK; VSYNC; HSYNC; DE; DR[7:0]; DG[7:0]; DB[7:0]

Note: LVDS interface Display signal: DCLK P/N; RX[3:0]P/N

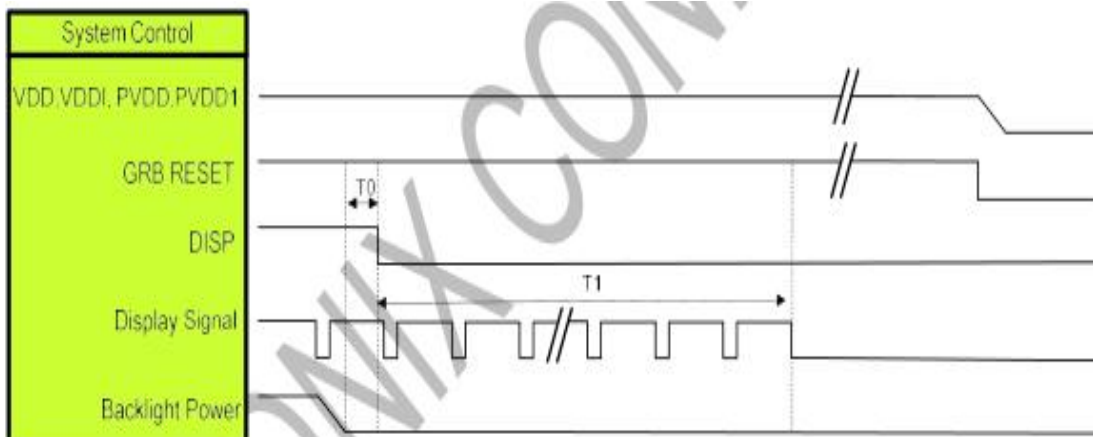

Symbol	Description	Min. Time	Unit
T0	Backlight Power off to DISP="Low"	5	ms
T1	DISP="Low" to IC internal voltage discharge complete	100	ms

Note: RGB interface Display signal: DCLK; VSYNC; HSYNC; DE; DR[7:0]; DG[7:0]; DB[7:0]

Note: LVDS interface Display signal: DCLK P/N; RX[3:0]P/N

4.5. Timing for RGB Interface

RGB 接口时序

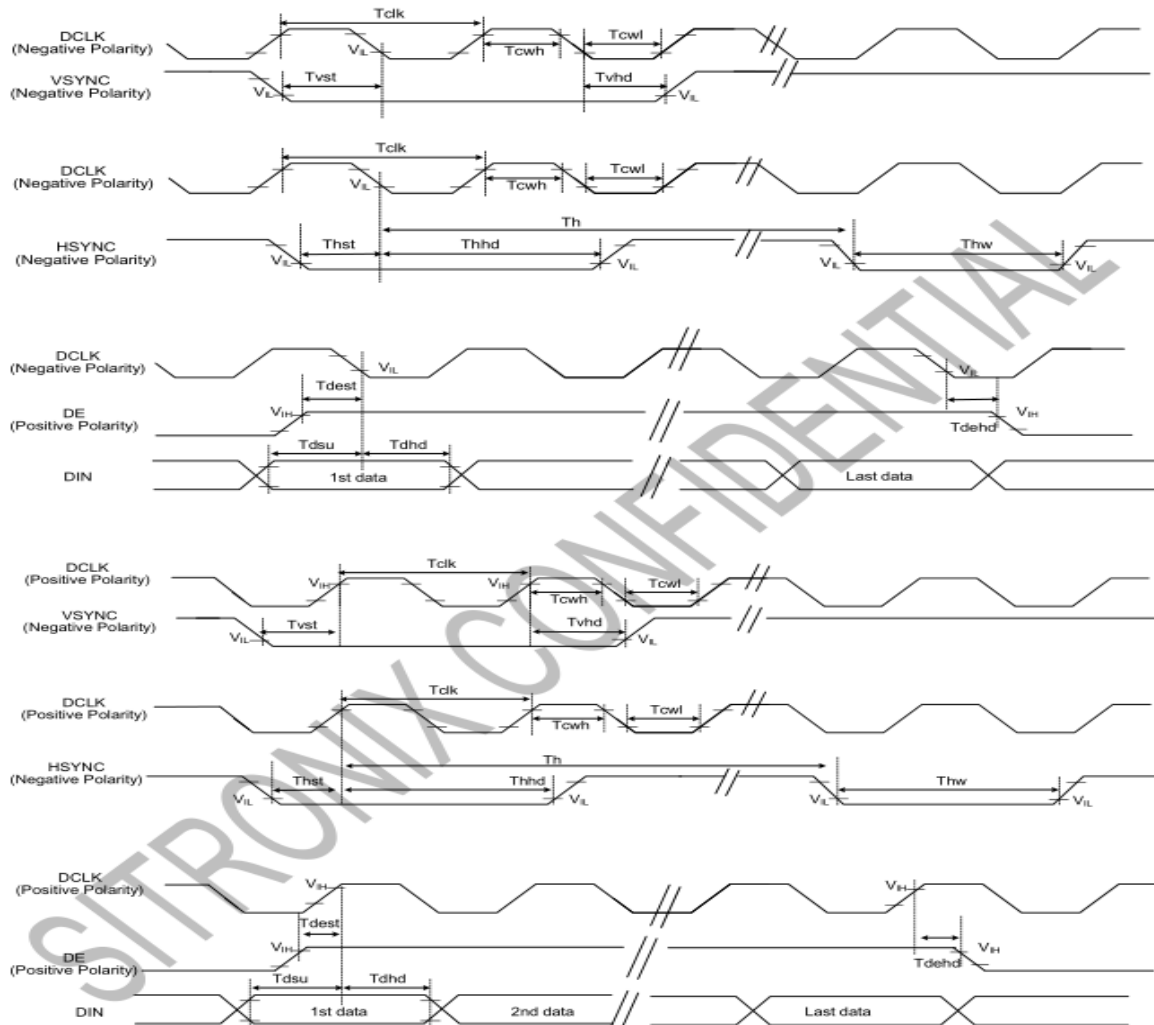

Item	Symbol	Min.	Typ.	Max.	Unit	Conditions
CLK Pulse Duty	T _{cw}	40	50	60	%	
VSYNC Setup Time	T _{vst}	-	-	10	ns	
VSYNC Hold Time	T _{vhd}	-	-	10	ns	
HSYNC Setup Time	T _{hst}	-	-	10	ns	
HSYNC Hold Time	T _{hhd}	-	-	10	ns	
Data Setup Time	T _{dsu}	-	-	10	ns	
Data Hold Time	T _{dhd}	-	-	10	ns	
DE Setup Time	T _{dest}	-	-	10	ns	
DE Hold Time	T _{dehd}	-	-	10	ns	

4.6. Parallel 24 bit RGB Input Timing Table

并行 24 位 RGB 输入时序

Parallel 24-bit RGB Input Timing (PVDD=PVDD1=VDD=VDDI= 3.3V, AGND= 0V, TA=25°C)

Parallel 24-bit RGB Interface Timing Table							
Item	Symbol	Min.	Typ.	Max.	Unit	Remark	
DCLK Frequency		Fclk	23	25	27	MHz	
HSYNC	Period Time	Th	-	816	896	DCLK	
	Display Period	Thdisp	800			DCLK	
	Back Porch	Thbp	-	8	48	DCLK	
	Front Porch	Thfp	-	8	48	DCLK	
	Pulse Width	Thw	-	4	8	DCLK	
VSYNC	Period Time	Tv	-	496	504	HSYNC	
	Display Period	Tvdisp	480			HSYNC	
	Back Porch	Tvbp	-	8	12	HSYNC	
	Front Porch	Tvfp	-	8	12	HSYNC	
	Pulse Width	Tvw	-	4	8	HSYNC	

Note: The minimum blanking time depends on the GIP timing of the panel specification.

4.7. Electro-Optical Characteristic

光电特性

S

Parameter		Symbol	Condition	Min.	Typ.	Max.	Unit	Remark
Viewing Angle Range	Horizontal	Θ3	CR>10	70	80	-	Deg.	Note1
		Θ9		70	80	-	Deg.	
	Vertical	Θ12		70	80	-	Deg.	
		Θ6		70	80	-	Deg.	
Contrast ratio		CR	Θ = 0°	1000	1500	-		Note2
Transmittance		Tr		3.78	4.45		%	Note3
Color Gamut		CG		55	60		%	
Reproduction of color	Red	Rx	Θ = 0°	0.618	0.638	0.658		Note4 (Based on C Light)
		Ry		0.318	0.338	0.358		
	Green	Gx		0.276	0.296	0.316		
		Gy		0.555	0.575	0.595		
	Blue	Bx		0.117	0.137	0.157		
		By		0.104	0.124	0.144		
White Chromaticity		Wx	Θ = 0°	0.298	0.318	0.338		
		Wy		0.321	0.341	0.361		
Response Time (Rising + Falling)		T _r + T _f	Ta= 25° C Θ = 0°		30	40	ms	Note 5

5. Measurement System

测试系统

5.1. LCM

LCM 观看角度

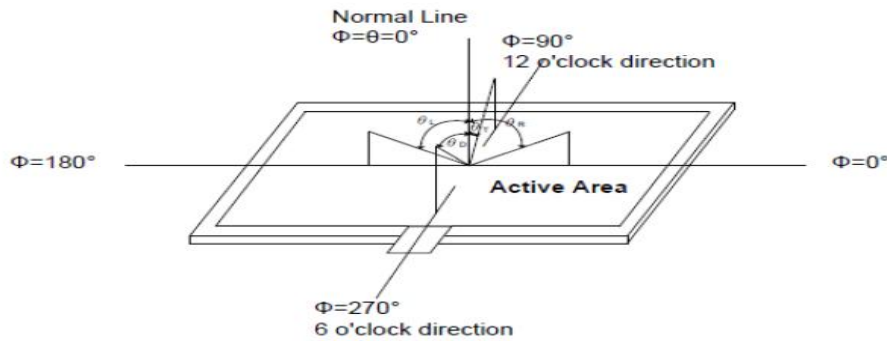

Viewing angle is the angle at which the contrast ratio is greater than 10. The angles are determined for the horizontal or x axis and the vertical or y axis with respect to the z axis which is normal to the LCD surface. 观看角度是对比度大于 10 的角度。角度是针对水平(x 轴)和垂直(y 轴)相对于与 LCD 表面垂直的 z 轴确定的。

5.2. Response Time

响应时间

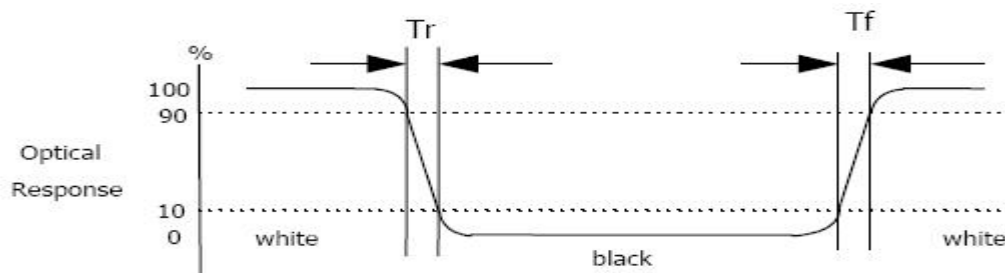

Response time is the time required for the display to transition from white to black (Rising time, T_r) and from black to white (Falling time, T_f) for additional information. 响应时间是显示器从白色过渡到黑色（上升时间， T_r ）和从黑色过渡到白色（下降时间， T_f ）以获取附加信息所需的时间。

5.3. Contrast Ratio (CR)

对比度

Contrast Ratio (CR) is defined mathematically as:

对比度 (CR) 在数学上定义为:

$$\text{Contrast Ratio} = \frac{\text{Surface Luminance with all white pixels}}{\text{Surface Luminance with all black pixels}}$$

$$\text{对比度} = \frac{\text{全白像素的表面亮度}}{\text{全黑像素的表面亮度}}$$

Surface luminance is the center point across the LCD surface 500mm from the surface with all pixels displaying white.

6. Reliability Test Items

可靠性测试项目

Test Item 测试项目	Test Condition 测试状态	Test result determinant gist 测试结果决定性要点
High temperature storage 高温 储存	80±3℃,48H;	1. Inspection after 2~4hours storage at room temperature, the sample shall be free from defects: a). Air bubble in the LCD; b). Non-display; c). Glass crack; 2. The electrical characteristics requirements shall be satisfied. 1. 样品在室温下存放 2~4 小时后检验, 样品应无缺 陷: a) LCD 中有气泡; b)不显示; C) 玻璃裂纹; 2、满足电气特性要求
Low temperature storage 低温 储存	-30±3℃,48H;	
High temperature operation 高 温运行	70±3℃,48H;	
Low temperature operation 低温运行	-20±3℃,48H;	
High temperature / humidity 高温/亮度	60℃±3℃,90%±3%RH,48H;	
Thermal Shock 热冲击	-20℃/0.5h~+70℃/0.5h for a total 24 cycles; 24 小时总循环	
Vibration Test 震动测试	Frequency:10Hz~55Hz~10Hz; Amplitude:1.5mm, X, Y, Z direction for total 1H; (Packing condition)	
ESD test ESD 测试	±4KV, Human Body Mode,150pF/330Ω; ±8KV, Air Mode, 150pF/330Ω;	

Remark:

备注

1.The test samples should be applied to only one test item.

测试样品只能应用于一个测试项目。

2.Sample size for each test item is 2pcs.

每个测试项目的样本大小为 2 个。

3.Failure Judgment Criterion: Basic Specification, Electrical Characteristic, Mechanical Characteristic, Optical Characteristic.

7. Suggestions for Using LCD Modules

LCD 模块的使用建议

1) The display panel is made of glass and polarizer. As glass is fragile. It tends chipped during handling especially on the edges. Please avoid dropping or jarring. Do not subject it to a mechanical shock by dropping it or impact.

显示面板由玻璃和偏光片制成。因为玻璃易碎，在处理过程中，特别是在边缘处，它会比较容易碎裂。请避免掉落或震动。请勿使其跌落或撞击而受到机械冲击。

2) If the display panel is damaged and the liquid crystal substance leaks out, be sure not to get any in your mouth. If the substance contacts your skin or clothes, wash it off using soap and water.

如果显示面板损坏和液晶物质泄漏，请务必不要让其进入您的嘴里。如果该物质接触到您的皮肤或衣服，请用肥皂和水清洗。

3) Do not apply excessive force to the display surface or the adjoining areas since this may cause the color tone to vary. Do not touch the display with bare hands. This will stain the display area and degraded insulation between terminals (some cosmetics are determined to the polarizer).

请勿对显示器表面或相邻区域施加过大的力，因为这可能会导致色调发生变化。请勿赤手触摸显示屏。这会弄脏显示区域。

4) The polarizer covering the display surface of the LCD module is soft and easily scratched. Please handle this polarizer carefully. Please do not touch, push or rub the exposed polarizers with anything harder than an HB pencil lead (glass, tweezers, etc.). Please do not put or attach anything on the display area to avoid leaving marks on it. Condensation on the surface and contact with terminals due to cold will be damaged, or dirty the polarizer. After products are tested at low temperature they must be warmed up in a container before coming in to contact with room temperature air.

覆盖在液晶模组显示面上的偏光片柔软，且容易划伤。请小心处理这个偏光片。请不要用比 HB 铅笔芯（玻璃、镊子等）更硬的任何东西接触、推动或摩擦暴露的偏光片。请勿在展示区域放置或粘贴任何物品，以免在其上留下痕迹。其表面冷凝和因寒冷而与端子接触会损坏或弄脏偏光片。产品在低温下测试后，必须在容器中预热，然后再与室温空气接触。

5) If the display surface becomes contaminated, exhale on the surface and gently wipe it with a soft dry cloth. If it is heavily contaminated, moisten cloth with one of the following solvents

- Isopropyl alcohol
- Ethyl alcohol

Do not scrub hard to avoid damaging the display surface.

如果显示器表面被污染，请在表面呼气并用柔软的无尘布轻轻擦拭。如果它被严重污染，请用以下溶剂之一弄湿布

- 无水丙醇 - 乙醇 请勿用力擦洗，以免损坏显示器表面。

6) Solvents other than those above-mentioned may damage the polarizer. Especially, do not use the following.

- Water
- Ketone
- Aromatic solvents

Wipe off saliva or water drops immediately, contact with water over a long period of time may cause deformation or color fading. Avoid contact with oil and fats.

6) 上述以外的溶剂可能会损坏偏光片。请勿使用以下溶剂。

- 水
- 丙酮

立即擦掉唾液或水滴，长时间与水接触可能会导致变形或褪色。避免接触油和脂肪。

7) Exercise care to minimize corrosion of the electrode. Corrosion of the electrodes is accelerated by water droplets, moisture condensation or a current flow in a high-humidity environment.

小心操作以尽量减少电极的腐蚀。水滴、湿气凝结或电流会加速电极的腐蚀。

8) Install the LCD Module by using the mounting holes. When mounting the LCD module make sure it is free of twisting, warping and distortion. In particular, do not forcibly pull or bend the I O cable or the backlight cable.

使用安装孔安装 LCD 模块。安装 LCD 模块时，请确保其没有扭曲、翘曲和变形。尤其不要强行拉扯或弯曲 I O 电缆或背光电缆。

9) Do not attempt to disassemble or process the LCD module.

请勿尝试拆卸或加工 LCD 模块。

10) NC terminal should be open. Do not connect anything.

NC 终端应打开。不要连接任何东西。

11) If the logic circuit power is off, do not apply the input signals.

如果逻辑电路电源关闭，请勿施加输入信号。

12) Electro-Static Discharge Control, since this module uses a CMOS LSI, the same careful attention should be paid to electrostatic discharge as for an ordinary CMOS IC. To prevent destruction of the elements by static electricity, be careful to maintain an optimum work environment.

- Before removing LCM from its packing case or incorporating it into a set, be sure the module and your body have the same electric potential. Be sure to ground the body when handling the LCD modules.

- Tools required for assembling, such as soldering irons, must be properly grounded. Make certain

the AC power source for the soldering iron does not leak. When using an electric screwdriver to attach LCM, the screwdriver should be of ground potentiality to minimize as much as possible any transmission of electromagnetic waves produced sparks coming from the commutator of the motor.

- To reduce the amount of static electricity generated, do not conduct assembling and other work under dry conditions. To reduce the generation of static electricity be careful that the air in the work is not too dry. A relative humidity of 50%-60% is recommended. As far as possible make the electric potential of your work clothes and that of the work bench the ground potential.

- The LCD module is coated with a film to protect the display surface. Exercise care when peeling off this protective film since static electricity may be generated.

静电放电控制，由于该模块使用 CMOS LSI，因此应与普通 CMOS IC 一样注意静电放电。为防止静电损坏元件，请注意保持最佳工作环境。

- 从包装箱中取出 LCM 或将其装入套件之前，请确保

模块和您的身体具有相同的电势。处理 LCD 模块时一定要把身体接地。

- 组装所需的工具，例如烙铁，必须正确接地。确保烙铁的交流电源不漏电。使用电动螺丝刀安装 LCM 时，螺丝刀应具有接地电位，以尽可能减少来自电机换向器产生的火花的电磁波传输。

- 为减少静电产生量，请勿在干燥条件下进行组装和其他工作。为减少静电的产生，请注意工作中的空气不要太干燥。建议相对湿度为 50%-60%。尽量使您的工作服和工作台的电位为地电位。- LCD 模块涂有一层薄膜以保护显示表面。剥离此保护膜时请小心，因为可能会产生静电。

13) Since LCM has been assembled and adjusted with a high degree of precision, avoid applying excessive shocks to the module or making any alterations or modifications to it.

- Do not alter, modify or change the shape of the tab on the metal frame.

- Do not make extra holes on the printed circuit board, modify its shape or change the positions of components to be attached.

- Do not damage or modify the pattern writing on the printed circuit board.

- Absolutely do not modify the zebra rubber strip (conductive rubber) or heat seal connector.

- Except for soldering the interface, do not make any alterations or modifications with a soldering iron.

- Do not drop, bend or twist the LCM.

。由于 LCM 已高精度组装和调整，请避免对模块施加过大的冲击或对其进行任何改动或修

改

- 请勿改动、修改或改变金属框架上拉环的形状。

- 不要在印刷电路板上打额外的孔，修改其形状或改变要连接的组件的位置。

- 不要损坏或修改印刷电路板上的图案书写。

- 绝对不要改装斑马橡胶条（导电橡胶）或热封接头。

- 除焊接接口外，请勿使用烙铁进行任何改动或修改。
- 不要掉落、弯曲或扭曲 LCM。

8. Storage Method

储存方法

1) Store in an ambient temperature of $23^{\circ}\text{C}\pm 5^{\circ}\text{C}$, and in a relative humidity of $55\%\pm 15\%$. Don't exceed 12 months and expose to sunlight or fluorescent light.

环境温度为 $23^{\circ}\text{C}\pm 5^{\circ}\text{C}$ ，相对湿度为 $55\%\pm 15\%$ 。不要超过 12 个月并暴露在阳光或荧光灯下。

2) Store in a clean environment, free from dust, active gas, and solvent.

存放在清洁的环境中，无灰尘、无活性气体和溶剂。

3) LCM module is stored in warehouse, Store in antistatic container, there may be air bubbles between the protective film on the surface of polarizer and polarizer. It can only be found under LED light, before production, IQC should be inspected directly by LED light, if residual traces are found, alcohol should be used to wipe them.

LCM 模块存放在仓库中，偏光片和偏光片表面的保护膜之间可能会有气泡。只能在 LED 灯下发现，生产前，IQC 应直接用 LED 灯检查，如有残留痕迹，可用酒精擦拭。