



**SPECIFICATION
FOR
LCD MODULE**

Customer : _____
Product Model: XM050VN40-R02
Sample code: _____

Designed by	Checked by	Approved by

Final Approval by Customer

<input type="checkbox"/> LCM Machinery OK Checked By _____ <input type="checkbox"/> LCM Display OK Checked By _____	<input type="checkbox"/> LCM OK <input type="checkbox"/> NG , Problem survey: Approved By _____
--	---

※The specification of "TBD" should refer to the measured value of sample . If there is difference between the design specification and measured value, we naturally shall negotiate and agree to solution with customer.

Contents

1. General Specifications	1
2. Pin Assignment	2
3. Operation Specifications	4
3.1. Absolute Maximum Ratings	4
3.1.1. Typical Operation Conditions	4
3.1.2. Backlight Driving Conditions	5
3.2. Power Sequence	6
3.3. Timing Characteristics	7
3.3.1. Sync Mode	7
3.3.2. De Mode.....	9
4. Optical Specifications	10
5. Reliability Test Items	14
6. General Precautions	15
6.1. Safety	15
6.2. Handling.....	15
6.3. Static Electricity.....	15
6.4. Storage	15
6.5. Cleaning	15
7. Mechanical Drawing	16

1. General Specifications

No.	Item	Specification	Remark
1	LCD size	5.0 inch(Diagonal)	
2	Driver element	a-Si TFT active matrix	
3	Resolution	800×3(RGB)×480	
4	Display mode	Normally White, Transmissive	
5	Dot pitch	0.135(W)×0.135(H) mm	
6	Active area	108(W)×64.8(H) mm	
7	Module size	120.7(W)×75.8(H)×2.8(D) mm	Note 1
8	Surface treatment	Anti-Glare	
9	Color arrangement	RGB-stripe	
10	Interface	Digital	
11	Backlight power consumption	TBD	
12	Panel power consumption	TBD	
13	Weight	TBD	

Note 1: Refer to Mechanical Drawing.

2. Pin Assignment

1	GLED	GND for LED
2	VLED	Power for LED
3	GND	Ground
4	VDD	Digital power supply(+3.3V)
5	R0	Red data(LSB)
6	R1	Red data
7	R2	Red data
8	R3	Red data
9	R4	Red data
10	R5	Red data
11	R6	Red data
12	R7	Red data(MSB)
13	G0	Green data(LSB)
14	G1	Green data
15	G2	Green data
16	G3	Green data
17	G4	Green data
18	G5	Green data
19	G6	Green data
20	G7	Green data(MSB)
21	B0	Blue data(LSB)
22	B1	Blue data
23	B2	Blue data
24	B3	Blue data
25	B4	Blue data
26	B5	Blue data
27	B6	Blue data
28	B7	Blue data(MSB)
29	GND	Ground

Suzhou Xi nxi an Technology Co. , LTD

30	DCLK	Data clk
31	DISP	Display ON/OFF control. Internally pulled high
32	HS	Horizontal sync input in RGB mode
33	VS	Vertical sync input in RGB mode
34	DE	Data Enable
35	NC	No connection
36	GND	Ground
37	XR	T/p X-Right(No connection)
38	YD	T/p Y-Bottom(No connection)
39	XL	T/p X-Left(No connection)
40	YU	T/p Y-Up(No connection)

3. Operation Specifications

3.1. Absolute Maximum Ratings

(Note 1)

Item	Symbol	Values		Unit	Remark
		Min.	Max.		
Supply voltage	V_{DD}	-0.3	4.5	V	
Operation Temperature	T_{OP}	-20	60	°C	
Storage Temperature	T_{ST}	-30	70	°C	
LED Reverse Voltage	VR	-	6	V	Each LED Note 2
LED Forward Current	IF	-	25	mA	Each LED

Note 1: The absolute maximum rating values of this product are not allowed to be exceeded at any times. Should a module be used with any of the absolute maximum ratings exceeded, the characteristics of the module may not be recovered, or in an extreme case, the module may be permanently destroyed.

Note 2: VR Conditions: Zener Diode 20mA

3.1.1. Typical Operation Conditions

Item	Symbol	Values			Unit	Remark
		Min.	Typ	Max.		
Power voltage	V_{DD}	3.0	3.3	3.6	V	Note 2
Current for Driver	$I_{V_{DD}}$	-	17	25	mA	
Input logic high voltage	V_{IH}	$0.8 V_{DD}$	-	V_{DD}	V	Note 3
Input logic low voltage	V_{IL}	0	-	$0.2 V_{DD}$	V	

3.1.2. Backlight Driving Conditions

Item	Symbol	Values			Unit	Remark
		Min.	Typ.	Max.		
Voltage for LED backlight	V_L	--	18	--	V	Note 1
Current for LED backlight	I_L	--	100	--	mA	
LED life time	-	-	20,000	-	Hr	Note 2

Note 1: The LED Supply Voltage is defined by the number of LED at $T_a=25^{\circ}\text{C}$ and $I_L=100\text{mA}$.

Note 2: The “LED life time” is defined as the module brightness decrease to 50% original brightness at $T_a=25^{\circ}\text{C}$ and $I_L=100\text{mA}$. The LED lifetime could be decreased if operating I_L is larger than 40mA.

LED CIRCUIT

3.2. Power Sequence

Power on sequence

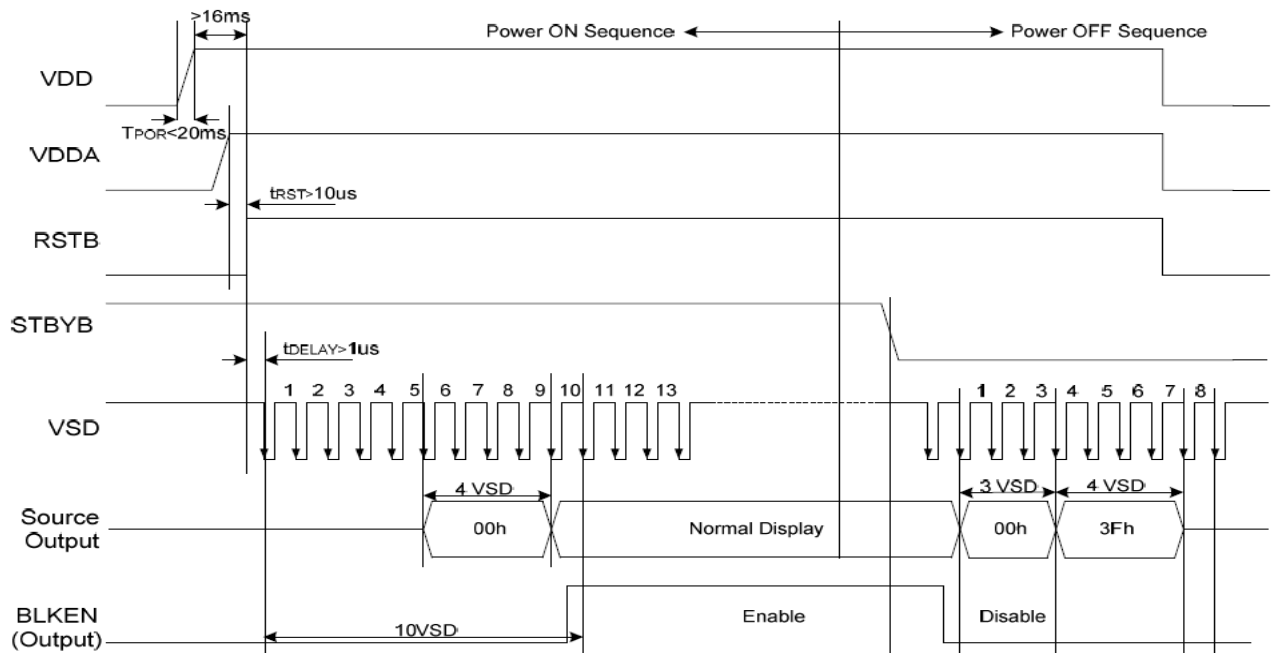

Note: For prevent anormal operation, t_{RST} must be longer than $10\mu\text{s}$ during Power ON sequence.

Power off sequence

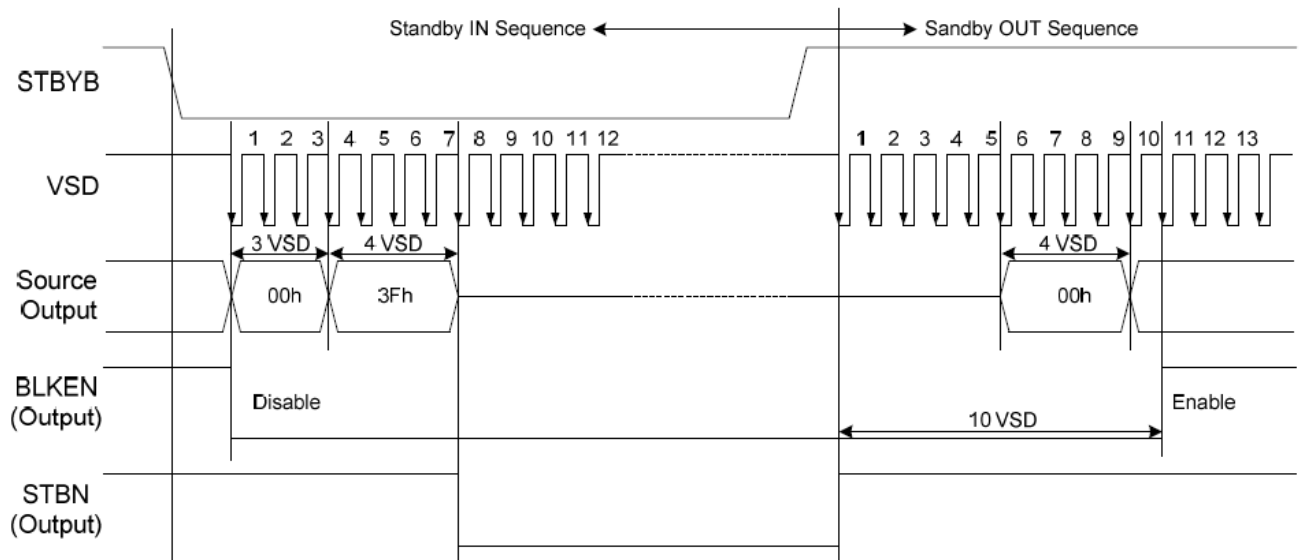

3.3. Timing Characteristics

3.3.1. Sync Mode

Horizontal Input Timing

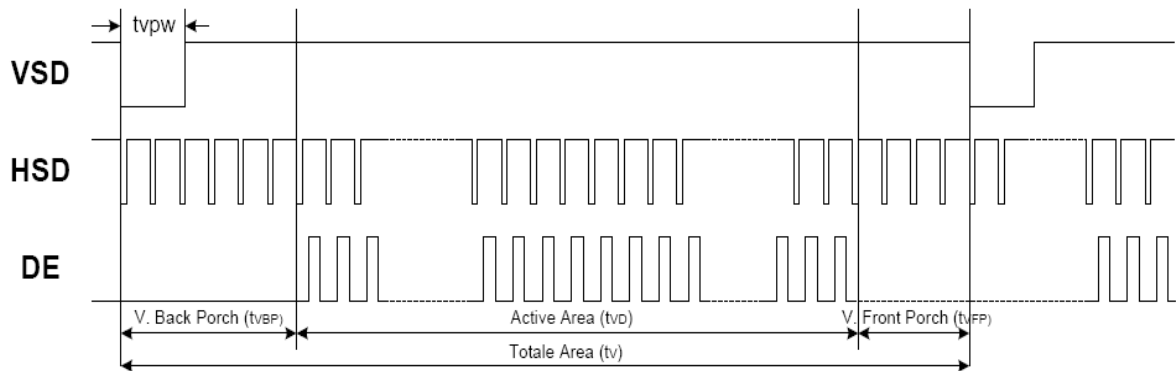
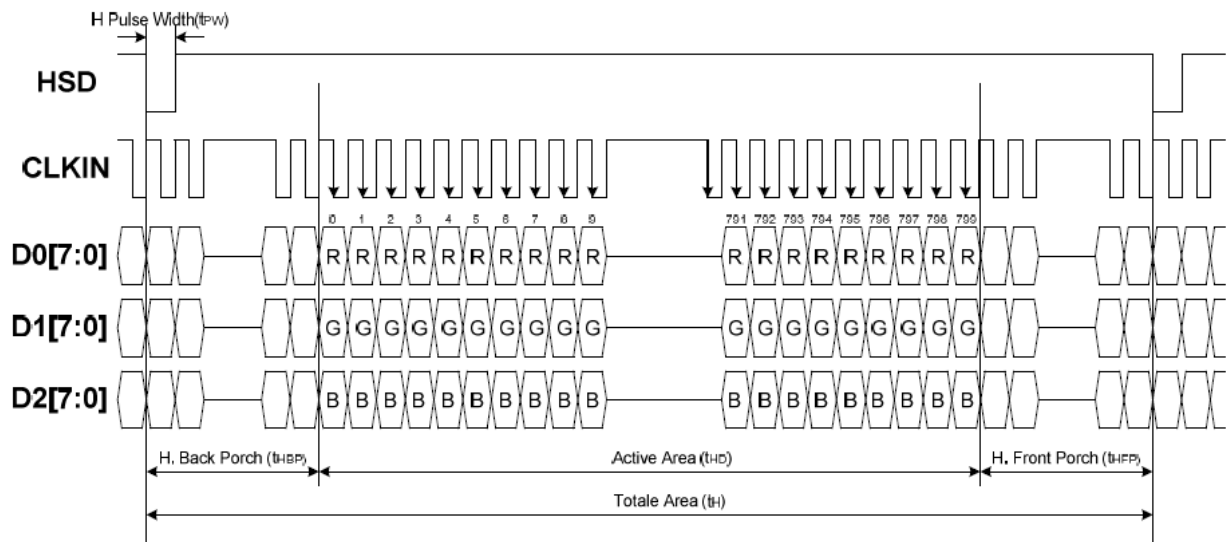

Suzhou Xi nxi an Technology Co., LTD

Timing Table

Parameter	Symbol	Spec			Unit	Conditions
		Min.	Typ.	Max.		
VDD Power ON slew rate	t _{POR}	--	--	20	ms	0V ~ 0.9VDD
RSTB pulse width	t _{RST}	10	--	--	us	CLKIN=50MHz
CLKIN cycle time	t _{CPH}	20	--	--	ns	
CLKIN pulse duty	t _{CWH}	40	50	60	%	
VSD setup time	t _{VST}	8	--	--	ns	
VSD hold time	t _{VHD}	8	--	--	ns	
HSD setup time	t _{HST}	8	--	--	ns	
HSD hold time	t _{HHD}	8	--	--	ns	
Data setup time	t _{DST}	8	--	--	ns	D0[7:0], D1[7:0], D2[7:0] to CLKIN
Data hold time	t _{DHD}	8	--	--	ns	D0[7:0], D1[7:0], D2[7:0] to CLKIN
DE setup time	t _{EST}	8	--	--	ns	
DE hold time	t _{EHD}	8	--	--	ns	
Output stable time	t _{SST}	--	--	6	us	10% to 90% target voltage. CL=120pF, R=10KΩ
CLKIN frequency	f _{CLK}	--	40	50	MHz	VDD=3.0 ~ 3.6V
CLKIN cycle time	t _{CLK}	20	25	--	ns	
CLKIN pulse duty	t _{CWH}	40	50	60	%	T _{CLK}
Time from HSD to Source output	t _{HSD}	--	20	--	CLKIN	
Time from HSD to LD	t _{HLD}	--	20	--	CLKIN	Note (2)
Time from HSD to STV	t _{HSTV}	--	2	--	CLKIN	
Time from HSD to CKV	t _{HCKV}	--	20	--	CLKIN	
Time from HSD to OEV	t _{HOEV}	--	4	--	CLKIN	
LD pulse width	t _{WLD}	--	10	--	CLKIN	Note (2)
CKV pulse width	t _{WCKV}	--	66	--	CLKIN	
OEV pulse width	t _{WEOEV}	--	74	--	CLKIN	

Note: (1) VDD=3.0 ~ 3.6V, VDDA=6.5~13.5V, DGND=AGND=0V, Ta=-20~+85℃

(2) The contents of the data register are transferred to the latch circuit at the rising edge of LD. Then the gray scale voltage is output from the device at the falling edge of LD.

(3) Output loading condition :

3.3.2. De Mode

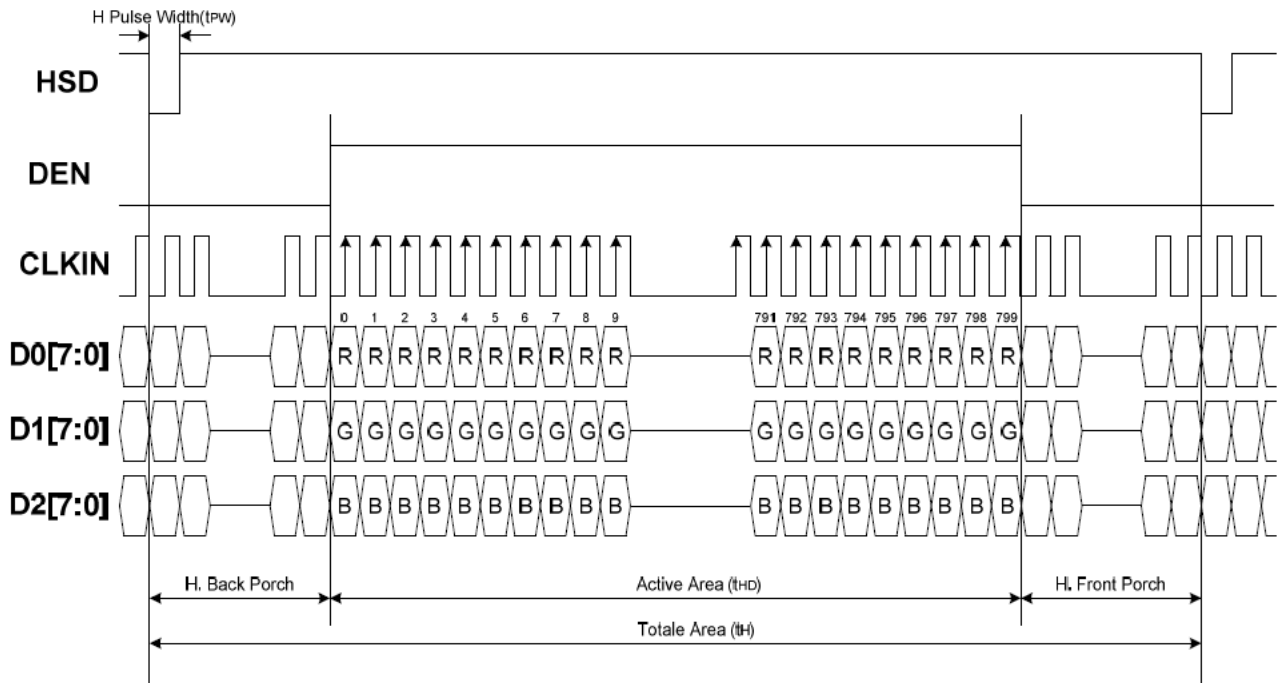

4. Optical Specifications

Item	Symbol	Condition	Values			Unit	Remark
			Min.	Typ.	Max.		
Viewing angle (CR≥ 10)	θ_L	$\Phi=180^\circ$ (9 o'clock)	-	70	-	degree	Note 1
	θ_R	$\Phi=0^\circ$ (3 o'clock)	-	70	-		
	θ_T	$\Phi=90^\circ$ (12 o'clock)	-	50	-		
	θ_B	$\Phi=270^\circ$ (6 o'clock)	-	70	-		
Response time	T_{ON}	Normal $\theta=\Phi=0^\circ$	-	10	20	msec	Note 3
	T_{OFF}		-	10	20	msec	Note 3
Contrast ratio	CR		500	700	-	-	Note 4
Color chromaticity	W_X		0.26	0.31	0.36	-	Note 2 Note 5
	W_Y		0.28	0.33	0.38	-	Note 6
Luminance	L		-	1000	-	cd/m ²	Note 6
Luminance uniformity	Y_U		70	75	-	%	Note 7

Test Conditions:

1. $V_{DD}=3.3V$, $I_L=100mA$ (Backlight current), the ambient temperature is $25^\circ C$.
2. The test systems refer to Note 2.

Note 1: Definition of viewing angle range

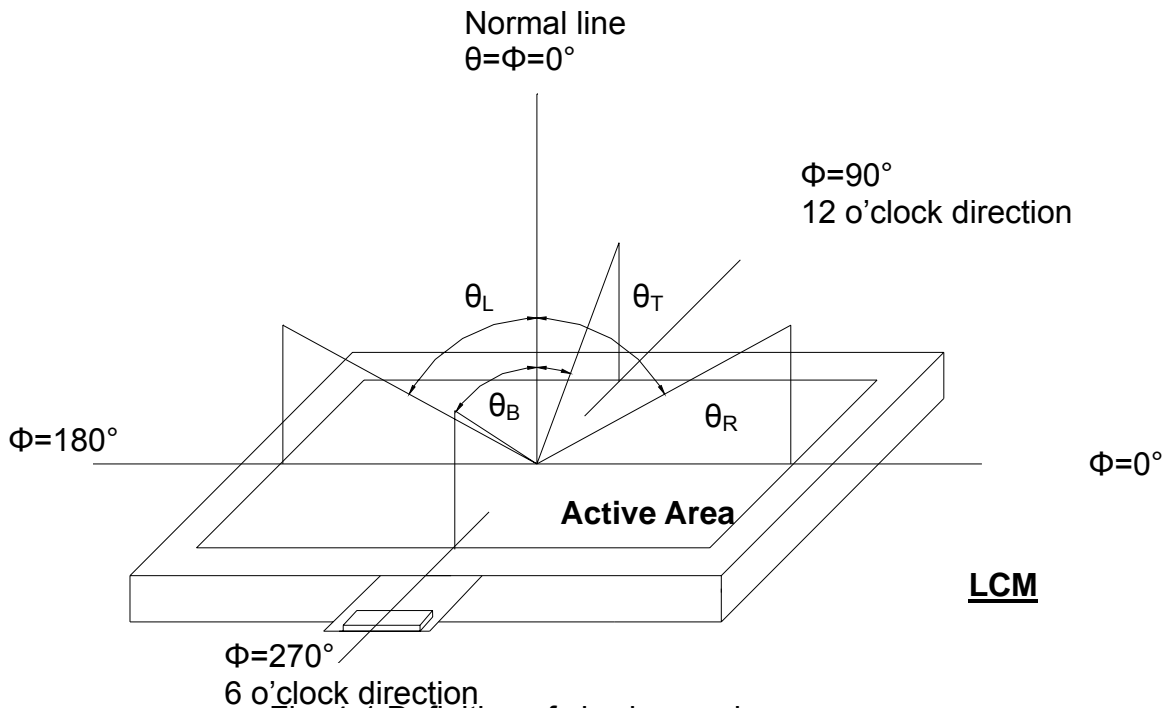

Fig. 4-1 Definition of viewing angle

Note 2: Definition of optical measurement system.

The optical characteristics should be measured in dark room. After 30 minutes operation, the optical properties are measured at the center point of the LCD screen. (Response time is measured by Photo detector TOPCON BM-7, other items are measured by BM-5A/Field of view: 1° /Height: 500mm.)

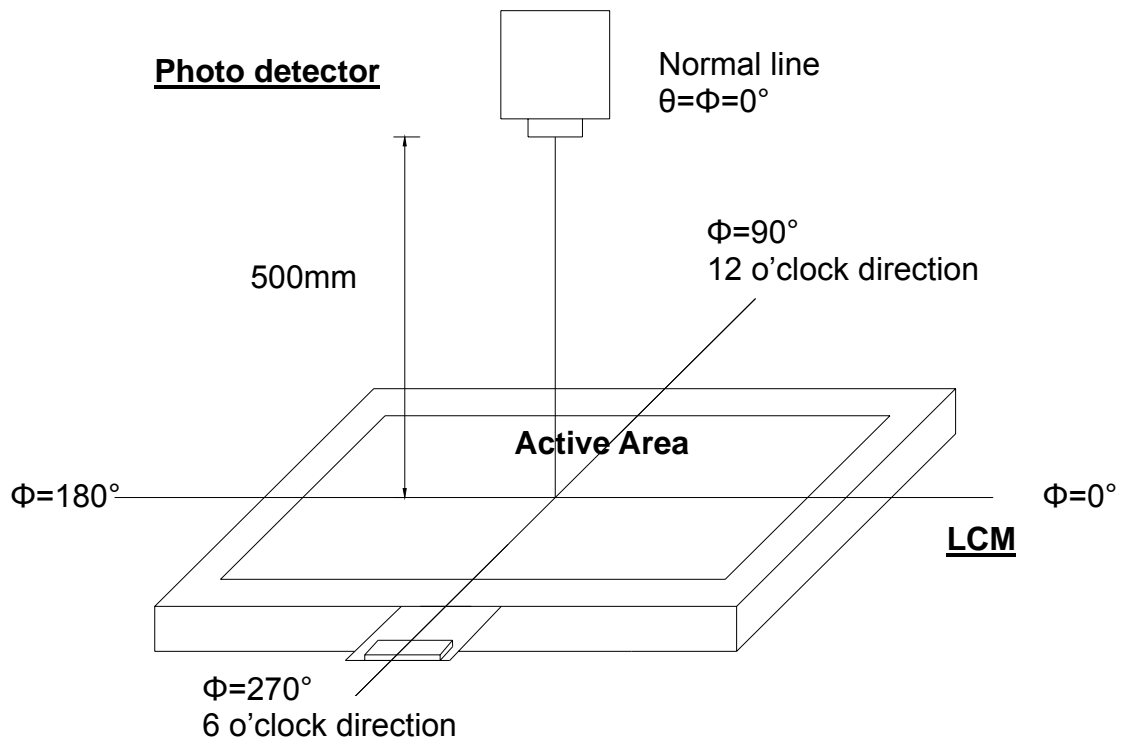

Fig. 4-2 Optical measurement system setup

Note 3: Definition of Response time

The response time is defined as the LCD optical switching time interval between "White" state and "Black" state. Rise time (T_{ON}) is the time between photo detector output intensity changed from 90% to 10%. And fall time (T_{OFF}) is the time between photo detector output intensity changed from 10% to 90%.

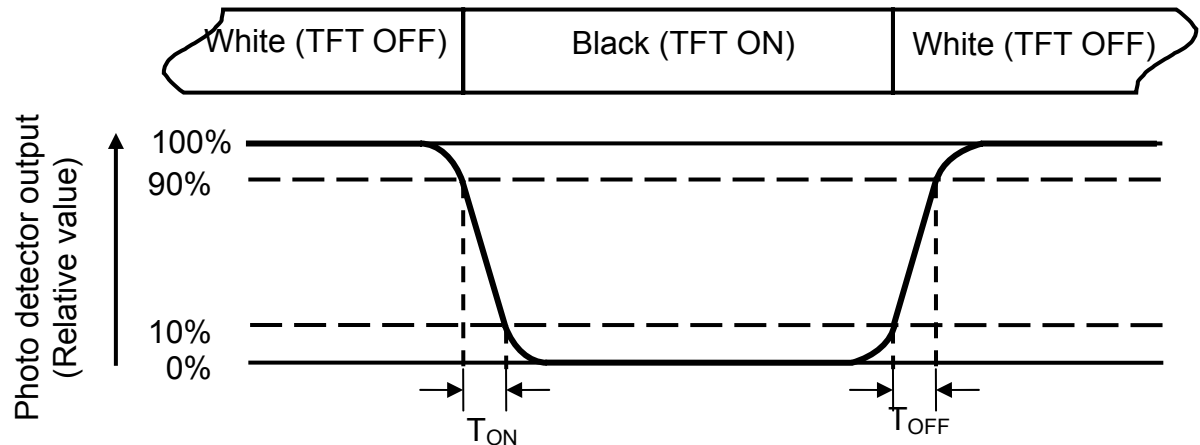

Fig. 4-3 Definition of response time

Note 4: Definition of contrast ratio

$$\text{Contrast ratio (CR)} = \frac{\text{Luminance measured when LCD on the "White" state}}{\text{Luminance measured when LCD on the "Black" state}}$$

Note 5: Definition of color chromaticity (CIE1931)

Color coordinates measured at center point of LCD.

Note 6: All input terminals LCD panel must be ground while measuring the center area of the panel. The LED driving condition is $I_L=100\text{mA}$.

Note 7: Definition of Luminance Uniformity

Active area is divided into 9 measuring areas (Refer to Fig. 4-4).Every measuring point is placed at the center of each measuring area.

$$\text{Luminance Uniformity } (Yu) = \frac{B_{min}}{B_{max}}$$

L-----Active area length W----- Active area width

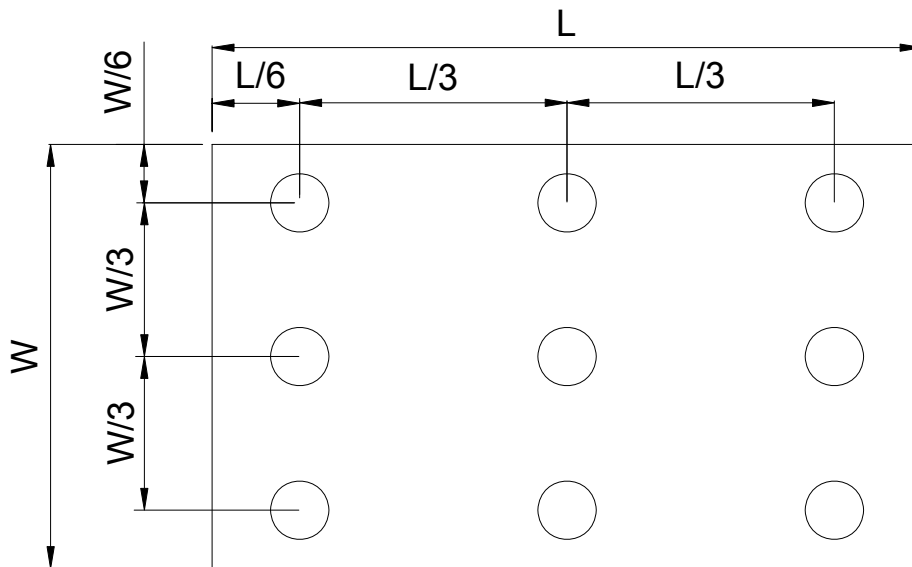

Fig. 4-4 Definition of measuring points

B_{max} : The measured maximum luminance of all measurement position.

B_{min} : The measured minimum luminance of all measurement position.

6. General Precautions

6.1. Safety

Liquid crystal is poisonous. Do not put it in your mouth. If liquid crystal touches your skin or clothes, wash it off immediately by using soap and water.

6.2. Handling

1. The LCD panel is plate glass. Do not subject the panel to mechanical shock or to excessive force on its surface.
2. The polarizer attached to the display is easily damaged. Please handle it carefully to avoid scratch or other damages.
3. To avoid contamination on the display surface, do not touch the module surface with bare hands.
4. Keep a space so that the LCD panels do not touch other components.
5. Put cover board such as acrylic board on the surface of LCD panel to protect panel from damages.
6. Transparent electrodes may be disconnected if you use the LCD panel under environmental conditions where the condensation of dew occurs.
7. Do not leave module in direct sunlight to avoid malfunction of the ICs.

6.3. Static Electricity

1. Be sure to ground module before turning on power or operating module.
2. Do not apply voltage which exceeds the absolute maximum rating value.

6.4. Storage

1. Store the module in a dark room where must keep at $25\pm 10^{\circ}\text{C}$ and 65%RH or less.
2. Do not store the module in surroundings containing organic solvent or corrosive gas.
3. Store the module in an anti-electrostatic container or bag.

6.5. Cleaning

1. Do not wipe the polarizer with dry cloth. It might cause scratch.
2. Only use a soft sloth with IPA to wipe the polarizer, other chemicals might permanent damage to the polarizer.

