

# PRODUCT SPECIFICATION

**Doc. Number:**

- Tentative Specification
- Preliminary Specification
- Approval Specification

**MODEL NO.: YH024RHQ4001**

**SUFFIX: S01**

<b>Customer:</b>	
<b>APPROVED BY</b>	<b>SIGNATURE</b>
<b>Name / Title</b> _____	
Note : _____	
Please return 1 copy for your confirmation with your signature and comments .	

Approved By	Checked By	Prepared By
		MW Chen



## Table of Contents

1. General Specification .....	3
2. TFT LCD Display Drawing (Non Touch Version) .....	4
3. TFT LCD Display Drawing (Resistive Touch Version) .....	5
4. TFT LCD Display Drawing (Cover Lens Bezel Version – Non Touch).....	6
5. Absolute Maximum Ratings .....	7
6. Electrical Characteristics .....	7
7. Electro-Optical Characteristics .....	7
8. Backlight Characteristics .....	8
9. Interface Descriptions .....	10
9.1. LCD Interface .....	10
10. Initialisation Code .....	11
11. LCD Timing Details .....	13
11.1. Timing Chart .....	13
11.2. Reset Timing .....	14
11.3. Power On Sequence .....	14
11.3.1. Case 1 - RES line is held High or Unstable by Host at Power ON .....	14
11.3.2. Case 2 - RES line is held Low by Host at Power ON.....	15
11.4. Power-off Sequence - Uncontrolled Power Off .....	15
12. Reliability Test .....	16
13. Legal Information.....	17

## 1. General Specification

YH024RHQ4001 is a colour active matrix LCD module incorporating amorphous silicon TFT (Thin Film Transistor). It is composed of a colour TFT-LCD panel, driver IC, FPC and a back light unit and with/without a Resistive Touch Panel (RTP), and with/without a Cover Lens Bezel (CLB). The module display area contains 240 x 320 pixels. This product accords with RoHS environmental criterion.

ITEM		CONTENTS	UNIT
LCD Type		TFT / Transmissive / Normally white	
Size		2.4	Inch
Viewing Direction		6:00 (without image inversion)	O'Clock
Gray Scale Inversion Direction		12:00	O'Clock
LCD (W × H)		42.72 x 60.26	mm <sup>3</sup>
Active Area (W × H)		36.72 × 48.96	mm <sup>2</sup>
Dot Pitch (W × H)		0.153 × 0.153	mm <sup>2</sup>
Number of Dots (Pixels)		240 (RGB) × 320	
Driver IC		ILI9341V	
Backlight Type		4 LEDs	
Surface Luminance	24320240	228 (typical)	cd/m <sup>2</sup>
	24320240-CLB	221 (typical)	
	24320240-RTP	182 (typical)	
Interface Type		MCU-8/16bit	
Color Depth		16.7M	
Pixel Arrangement		RGB Vertical Stripe	
Surface Treatment		AG	
Input Voltage		2.8 (typical)	V
With/Without TP (Touch Panel)		24320240 - Without TP 24320240-CLB – Without TP, with CLB 24320240-RTP – With Resistive Touch	
Weight	24320240	11.0	g
	24320240-CLB	19.8	
	24320240-RTP	16.2	

**Note 1:** RoHS compliant

**Note 2:** LCD weight tolerance: ± 5%.

### Part Number Details:

LCD	TFT Systems LCD Display
24320240	2.4 inch, 240 x 320 Resolution
RTP	Resistive Touch
CLB	Cover Lens Bezel



## 5. Absolute Maximum Ratings

PARAMETER	SYMBOL	MIN	MAX	UNIT
Supply Voltage for LCD Logic	VDD/VCC	-0.3	4.6	V
Supply Voltage for TP Logic	VDD/VCC-VSS	-	-	V
Input Voltage for Logic	VIN	VSS-0.5	VDD	V
LED forward voltage (each LED)	IF	-	25	mA
Operating Temperature	T <sub>OP</sub>	-20	70	°C
Storage Temperature	T <sub>ST</sub>	-30	80	°C
Humidity	RH	-	90% (Max 60°C)	RH

## 6. Electrical Characteristics

PARAMETER	SYMBOL	MIN	TYP	MAX	UNIT
Power Voltage	VDD/DCC	2.6	2.8	3.3	V
Input Current	IVDD	-	-	-	mA
Input Voltage 'H' Level	V <sub>IH</sub>	0.7 VDD	-	VDD	V
Input Voltage 'L' Level	V <sub>IL</sub>	0	-	0.3 VDD	V

## 7. Electro-Optical Characteristics

ITEM	SYM	CONDITION	MIN	TYP	MAX	UNIT	REMARK
Response Time	Tr+Tf	$\theta=0$	-	30	-	ms	Figure 1 (4)
Contrast Ratio	Cr	$^{\circ}$	-	250	-	-	Figure 2 (1)
Luminance Uniformity	$\delta$ WHITE	$\phi=0$	75	80	-	%	Figure 2 (3)
Surface Luminance	Lv	4DLCD-24320240	205	228	-	cd/m <sup>2</sup>	Figure 2 (2)
		4DLCD-24320240-RTP	164	182			
		4DLCD-24320240-CLB	199	221			
Viewing Angle Range	$\theta$	$\phi = 90^{\circ}$	-	35	-	deg	Figure 3 (6)
		$\phi = 270^{\circ}$	-	55	-	deg	
		$\phi = 0^{\circ}$	-	55	-	deg	
		$\phi = 180^{\circ}$	-	55	-	deg	
CIE (x,y) Chromacity	Red	x	$\theta=0^{\circ}$ $\phi=0^{\circ}$ Ta=25	0.574	0.624	0.674	Figure 2 (5)
		y		0.318	0.368	0.418	
	Green	x		0.3	0.35	0.4	
		y		0.5	0.55	0.6	
	Blue	x		0.093	0.143	0.193	
		y		0.069	0.119	0.169	
	White	x		0.26	0.31	0.36	
		y		0.283	0.333	0.383	

## 8. Backlight Characteristics

PARAMETER	SYMBOL	MIN	TYP	MAX	UNIT
Voltage for LED backlight	V <sub>l</sub>	-	3.2	3.4	V
Current for LED backlight	I <sub>l</sub>	-	80	100	mA
LED Life Time	-	30000	-	-	Hrs

**Note:** The LED life time is defined as the module brightness decrease to 50% original brightness at Ta=25°C.

**Note 1:** Contrast Ratio(CR) is defined mathematically as below, for more information see Figure 1.

$$\text{Contrast Ratio} = \frac{\text{Average Surface Luminance with all white pixels (P1, P2, P3, P4, P5)}}{\text{Average Surface Luminance with all black pixels (P1, P2, P3, P4, P5)}}$$

**Note 2:** Surface luminance is the LCD surface from the surface with all pixels displaying white. For more information, see Figure 2.

L<sub>v</sub> = Average Surface Luminance with all white pixels (P1, P2, P3, P4, P5)

**Note 3:** The uniformity in surface luminance δ WHITE is determined by measuring luminance at each test position 1 through 5, and then dividing the maximum luminance of 5 points luminance by minimum luminance of 5 points luminance. For more information, see Figure 2.

$$\delta \text{ WHITE} = \frac{\text{Minimum Surface Luminance with all white pixels (P1, P2, P3, P4, P5)}}{\text{Maximum Surface Luminance with all white pixels (P1, P2, P3, P4, P5)}}$$

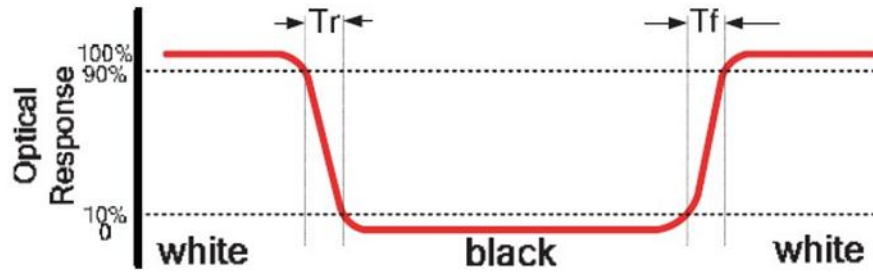
**Note 4:** Response time is the time required for the display to transition from white to black (Rise Time, Tr) and from black to white (Decay Time, Tf). For additional information see FIG 1. The test equipment is Autronic-Melchers ConoScope series.

**Note 5:** CIE (x, y) chromaticity, the x, y value is determined by measuring luminance at each test position 1 through 5, and then make average value.

**Note 6:** Viewing angle is the angle at which the contrast ratio is greater than 2. For TFT module the contrast ratio is greater than 10. The angles are determined for the horizontal or x axis and the vertical or y axis with respect to the z axis which is normal to the LCD surface. For more information, see Figure3.

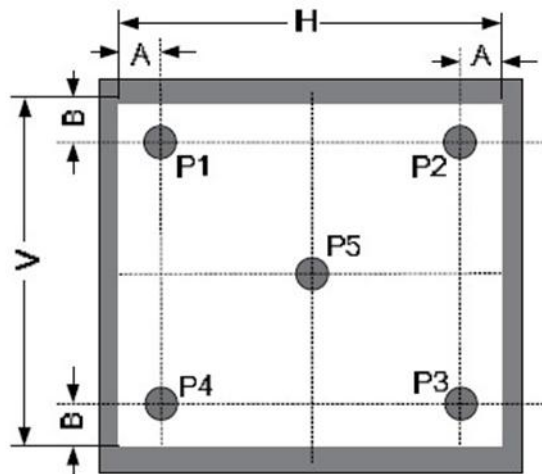
**Note 7:** For viewing angle and response time testing, the testing data is based on Autronic-Melchers ConoScope series. Instruments for Contrast Ratio, Surface Luminance, Luminance Uniformity, CIE the test data is based on TOPCONs BM-5 photo detector.

**Figure 1.** The definition of response time

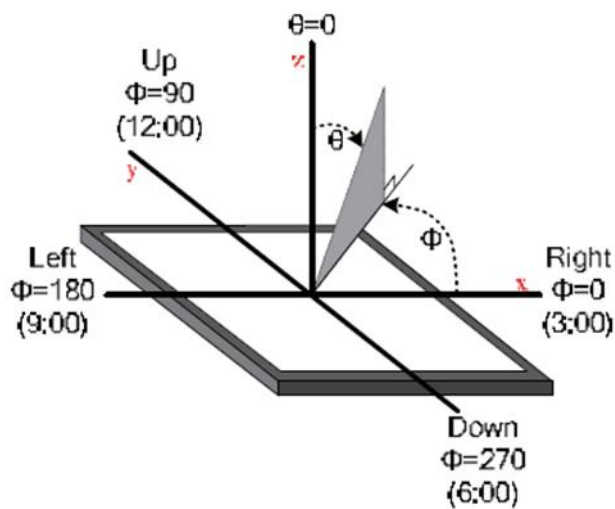


**Figure 2.** Measuring method for Contrast ratio, surface luminance, Luminance uniformity, CIE (x, y) chromaticity

A : 5 mm  
 B : 5 mm  
 H, V : Active Area  
 Light spot size  $\varnothing=5\text{mm}$ , 500mm distance from the LCD surface to detector lens  
 measurement instrument is TOPCON's luminance meter BM-5



**Figure 3.** The definition of viewing angle



## 9. Interface Descriptions

### 9.1. LCD Interface

PIN NO.	SYMBOL	DESCRIPTION	REMARK
1	GND	Ground	
2	GND	Ground	
3	IM0	8/16bit selection pin	Note 1
4	FMARK	Tearing effect output signal	
5	YD/NC	The touch panel Y bottom pin	
6	XL/NC	The touch panel X left pin	
7	RESET	Reset input signal	
8	RS	Data/Command selection pin	
9	CS	Chip select input pin	
10	RD	Read signal	
11	WR	Write signal	
12	VCC	Power supply	
13	NC	No Connect	
14	GND	Ground	
15	DB15	Databus DB15	
16	DB14	Databus DB14	
17	DB13	Databus DB13	
18	DB12	Databus DB12	
19	DB11	Databus DB11	
20	DB10	Databus DB10	
21	DB9	Databus DB9	
22	DB8	Databus DB8	
23	DB7	Databus DB7	
24	DB6	Databus DB6	
25	DB0	Databus DB0	
26	DB1	Databus DB1	
27	DB2	Databus DB2	
28	DB3	Databus DB3	
29	DB4	Databus DB4	
30	DB5	Databus DB5	
31	YU/NC	The touch panel Y up pin	
32	XR/NC	The touch panel X right pin	
33	LEDA	Anode of LED Backlight	
34	LEDK1	Cathode1 of LED Backlight	
35	LEDK2	Cathode2 of LED Backlight	
36	LEDK3	Cathode3 of LED Backlight	
37	LEDK4	Cathode4 of LED Backlight	
38	NC	No Connect	
39	NC	No Connect	
40	GND	Ground	

**Note 1:** IM0(8/16) (pin 3)

IM0(8/16)	Interface	Remark
0	MCU 16bit	Databus:DB0~DB15
1	MCU 8bit	Databus:DB8~DB15

## 10. Initialisation Code

```
//*****Hardware reset*****//
LCD_RESET=1;
Delays(15);
LCD_RESET=0;
Delays(120);
LCD_RESET=1;
Delays(120);

//*****Start Initial Sequence*****//
write_reg(0xCF);
write_dat(0x00);
write_dat(0xC1);
write_dat(0x30);

write_reg(0xED);
write_dat(0x64);
write_dat(0x03);
write_dat(0x12)
write_dat(0x81)

write_reg(0xE8);
write_dat(0x85);
write_dat(0x10);
write_dat(0x7A);

write_reg(0xCB);
write_dat(0x39);
write_dat(0x2C);
write_dat(0x00);
write_dat(0x34);
write_dat(0x02);

write_reg(0xF7);
write_dat(0x20);

write_reg(0xEA);
write_dat(0x00);
write_dat(0x00);

write_reg(0xC0); //Power control
write_dat(0x21); //VRH[5:0]

write_reg(0xC1); //Power control
write_dat(0x13); //SAP[2:0]; BT[3:0]

write_reg(0xC5); //VCM control
write_dat(0x32);
write_dat(0x3C);

write_reg(0xC7); //VCM control2
write_dat(0x9C);
write_reg(0x36); // Memory Access Control
write_dat(0x08);
write_reg(0x3A);
write_dat(0x55);
write_reg(0xB1);
write_dat(0x00);
write_dat(0x16);
```

```
write_reg(0xB6); // Display Function Control
write_dat(0x0A);
write_dat(0xA2);

write_reg(0xF6);
write_dat(0x01);
write_dat(0x30);

write_reg(0xF2); // 3Gamma Function Disable
write_dat(0x00);

write_reg(0x26); //Gamma curve selected
write_dat(0x01);

write_reg(0xE0); //Set Gamma
write_dat(0x0F);
write_dat(0x1E);
write_dat(0x1B);
write_dat(0x0B);
write_dat(0x0E);
write_dat(0x08);
write_dat(0x47);
write_dat(0xB7);
write_dat(0x37);
write_dat(0x0B);
write_dat(0x14);
write_dat(0x05);
write_dat(0x0C);
write_dat(0x07);
write_dat(0x00);

write_reg(0xE1); //Set Gamma
write_dat(0x00);
write_dat(0x21);
write_dat(0x24);
write_dat(0x04);
write_dat(0x11);
write_dat(0x07);
write_dat(0x38);
write_dat(0x48);
write_dat(0x48);
write_dat(0x04);
write_dat(0x0B);
write_dat(0x0A);
write_dat(0x33);
write_dat(0x38);
write_dat(0x0F);

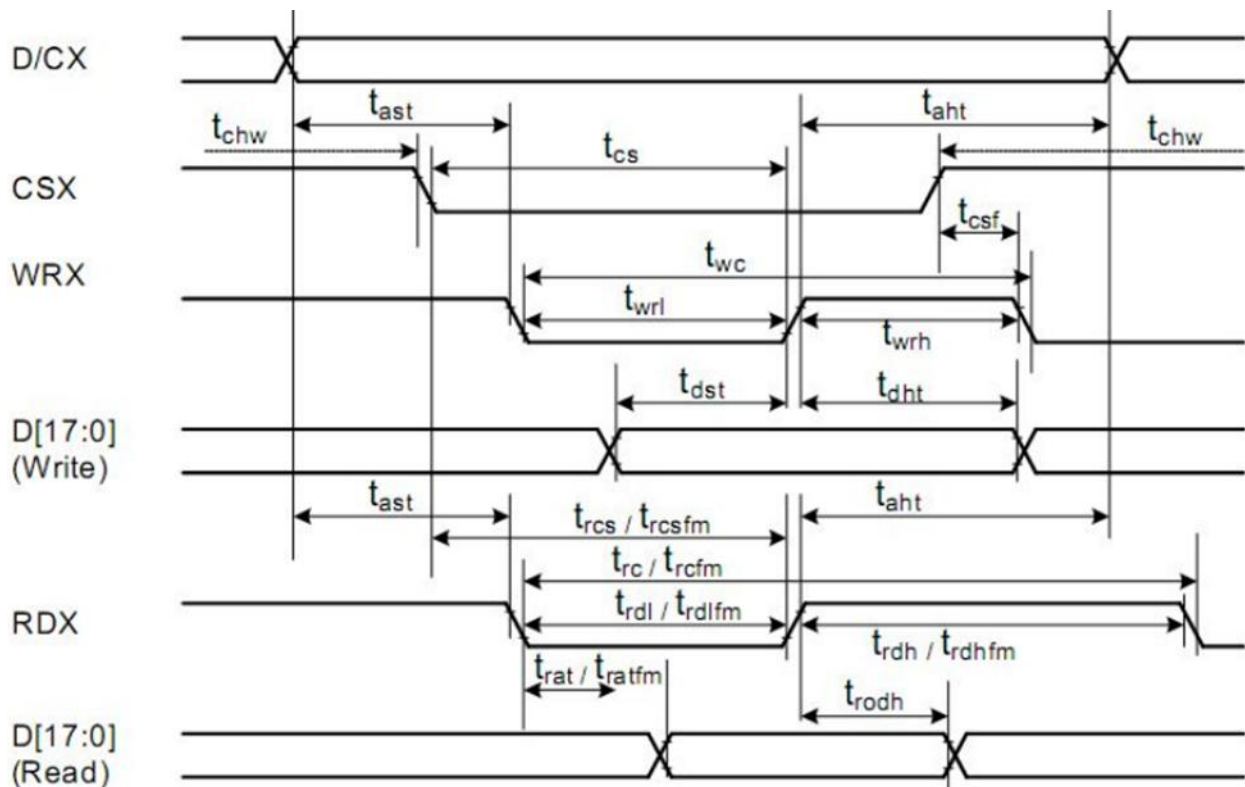
write_reg(0x11); //Exit Sleep
Delayms(120);
write_reg(0x29); //Display on
```

## 11. LCD Timing Details

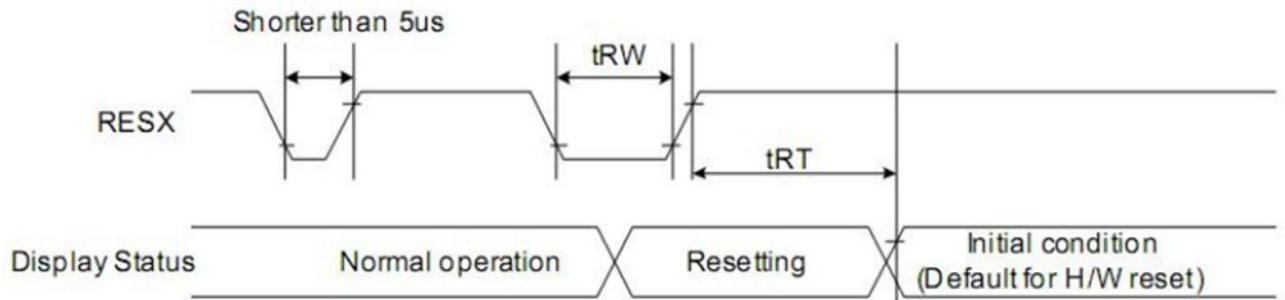
### 11.1. Timing Chart

SIGNAL	SYMBOL	PARAMETER	MIN	MAX	UNIT	DESCRIPTION
DCX	tast	Address setup time	0	-	ns	-
	taht	Address hold time (Write/Read)	0	-	ns	-
CSX	tchw	CSX "H" pulse width	0	-	ns	-
	tcs	Chip Select setup time	15	-	ns	-
	trcs	Chip Select setup time (Read ID)	45	-	ns	-
	trcsfm	Chip Select setup time (Read FM)	355	-	ns	-
	tcsf	Chip Select Wait time (Write/Read)	10	-	ns	-
WRX	twc	Write cycle	66	-	ns	-
	twrh	Write Control Pulse H duration	15	-	ns	-
	twrl	Write Control Pulse L duration	15	-	ns	-
RDX(FM)	trcfm	Read cycle (FM)	450	-	ns	-
	trdhfm	Read Control Pulse H duration (FM)	90	-	ns	-
	trdlfm	Read Control Pulse L duration (FM)	355	-	ns	-
RDX(ID)	trc	Read cycle (ID)	160	-	ns	-
	trdh	Read Control Pulse H duration	90	-	ns	-
	trdl	Read Control Pulse L duration	45	-	ns	-
D[17:0]	tdst	Write data setup time	10	-	ns	-
	tdht	Write data hold time	10	-	ns	-
	trat	Read access time	-	40	ns	-
	Tratfm	Read access time	-	340	ns	-
	trrod	Read output disable time	20	80	ns	-

Timing parameter (VDD=3.3V, GND=0V, Ta=25°C)



## 11.2. Reset Timing



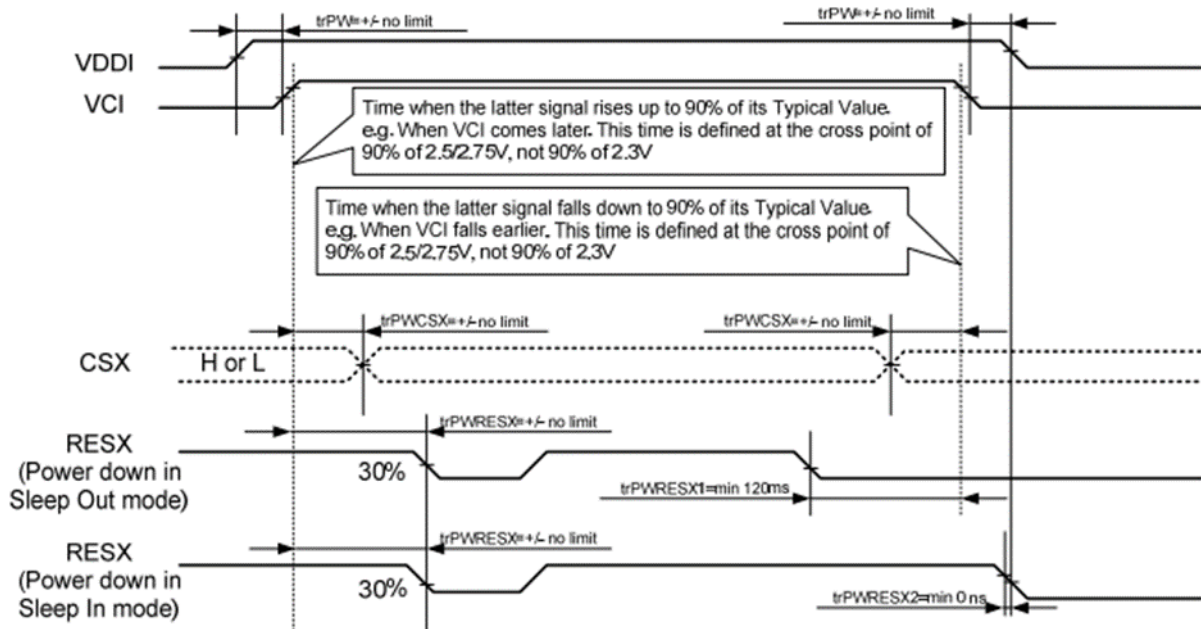
SIGNAL	SYMBOL	PARAMETER	MIN	MAX	UNIT
RESET	$t_{RW}$	Reset low pulse width	10	-	us
	$t_{RT}$	Reset complete time	-	5 (note1)	ms
			-	120 (note2)	ms

**Note 1:** When reset applied during SLPIN mode

**Note 2:** When reset applied during SLPOUT mode.

## 11.3. Power On Sequence

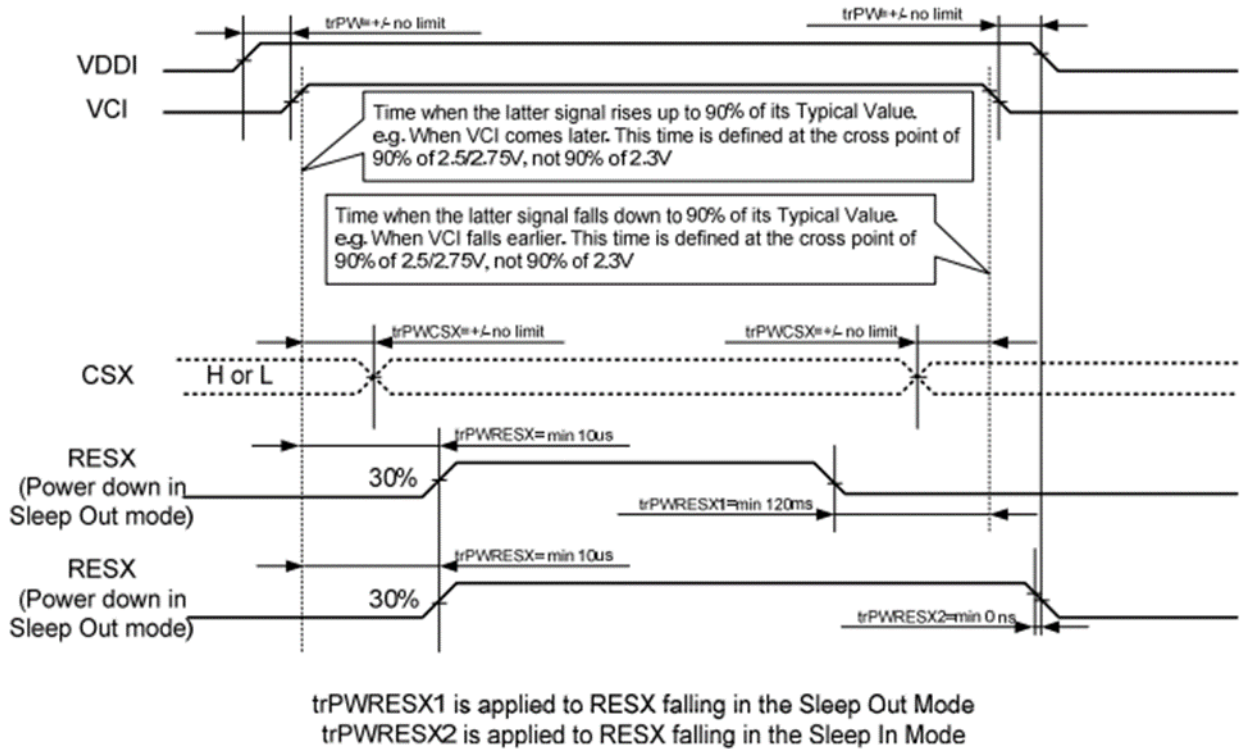
### 11.3.1. Case 1 - RES line is held High or Unstable by Host at Power ON



$t_{rPWRESX1}$  is applied to RESX falling in the Sleep Out Mode

$t_{rPWRESX2}$  is applied to RESX falling in the Sleep In Mode

### 11.3.2. Case 2 - RES line is held Low by Host at Power ON



### 11.4. Power-off Sequence - Uncontrolled Power Off

Uncontrolled power off is a situation where power is removed unexpectedly, e.g. a battery powering a device is disconnected without using the controlled power off sequence. There will not be any damage to the display module, nor will the display module cause any damage to the host. During an uncontrolled power off event, ILI9341V will force the display to blank its content and there will not be any further abnormal visible effects on the display after 1 second of the power being removed. The display will remain blank until the Power On Sequence occurs.

## 12. Reliability Test

No.	SYMBOL	TEST CONDITION	REMARK
1	High Temperature Storage	80°C±2°C 96H Restore 2H at 25°C Power off	After test cosmetic and electrical defects should not happen.
2	Low Temperature Storage	-30°C±2°C 96H Restore 2H at 25°C Power off	
3	High Temperature Operation	70°C±2°C 96H Power on	
4	Low Temperature Operation	-20°C±2°C 96H Power on	
5	High Temperature & Humidity Operation	60°C±2°C 90%RH 96H Power on	
6	Temperature Cycle	-20°C←→25°C←→70°C 30min 5min 30min  After 10 cycles, restore 2H at 25°C Power off	
7	Vibration Test	10Hz~150Hz, 100m/s <sup>2</sup> , 120min	
8	Shock Test	Half-sinewave, 300m/s <sup>2</sup> , 11ms	

---

### **13. Legal Information**

TFT systems makes nowarranty, either expressed or implied with respect to any product, and specifically disclaims all other warranties, including, without limitation, warranties for merchantability, non- infringement and fitness for any particular purpose. Information about device are the property of 4D systems and may be the subject of patents pending or granted. It is not allowed to copy or disclosed this document without prior written permission.