



深圳市宇华微科技有限公司

PRODUCT SPECIFICATION

Doc. Number:

- Tentative Specification
- Preliminary Specification
- Approval Specification

MODEL NO.: YH032BF3001

SUFFIX: M01

Customer:	
APPROVED BY	SIGNATURE
Name / Title _____	
Note : _____	
Please return 1 copy for your confirmation with your signature and comments .	

Approved By	Checked By	Prepared By
		MW Chen

1. Version Status

REV.NO.	DESCRIPTION	REMARK	DATE
V0	First Release	Original	2024.08.31

2. General Specifications

YH032BF3001 is a color active matrix TFT LCD module using amorphous silicon TFT's(Thin Film Transistors) as an active switching devices. This module has a 3.2 inch diagonally measured active area with DG resolutions(1024 horizontal by 768 vertical pixel array). Each pixel is divided into RED, GREEN, BLUE dots which are arranged in vertical stripe and this module can display 16.7M colors.

Item	Content	Unit	Note
Module Type	TFT	/	
Viewing direction	ALL	O'Clock	
Module outline	Refer to outline drawing	mm	1
Active Area(Φ)	64.512(H)*48.384(V)	mm	
Pixel Size	63*63	um	
Number of Dots	1024 x 768	dots	2
Controller IC	JD9168	/	
Backlight Typs	--	/	
Interface Type	MIPI	/	
F.P.C spec.	0.3	mm	3
Wight	--	g	
Input Voltage	3.3v	V	
Luminance for LCD	--	Cd/m ²	
TP IC	--		

Note 1:Refer to the outline drawing,you will find the detailed parameters,including the length,width,thickness

Note 2:Refer the Module Drawing

Note 3:Refer to the outline drawing, which includes a description of FPC dimensions

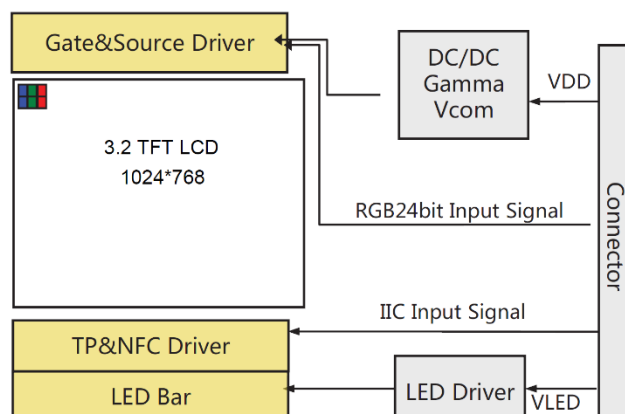

3 . Maximum Ratings

Parameter	Symbol	Spec			Unit	Note
		Min.	Typ.	Max.		
Analog Power supply	VCI	-0.3	-	6.6	V	-
I/O Voltage	VDDIO	-0.3	-	3.6	V	-
Operating temperature	Top	-20	-	70	°C	-
Storage temperature	Tstg	-30	-	80	°C	-
High Temp & Hum Operation	60°C 85%RH,240 hrs				/	-
Thermal shoc(non-operation)	-30°C(30min)~80(30min),50cycle				/	-

Note . The absolute maximum ratings are the values that must not be exceeded at any time for this product. It is not allowed for any of these ratings to be exceeded. In an extreme case, the product may be permanently destroyed.

4. Electrical Characteristics

4.1 Typical DC Characteristic: (Ta=25±2°C)

Parameter	Symbol	Min	Typ	Max	Unit	Note
Analog Supply Voltage	VCI	2.8	3.3	3.6	V	Note
Power Supply IO Voltage	IOVCC	2.5	3.3	3.3	V	
Input voltage	'H'	0.7* IOVCC	-	IOVCC	V	
	'L'	0	-	0.3* IOVCC	V	
Current Consumption		-	N/A	-	mA	
		-	N/A	-	mA	

Note: The supply voltage is measured and specified at the interface connector of LCM.
The current draw and power consumption specified is for 3.3V at 25°C
Max value at White Pattern, Frame Frequency=60HZ

4.2 Timing Characteristics

4.2.1 The 3.2 inch is operated by the DE only.

Parameter	Symbol	Spec			Unit
		Min.	Typ.	Max.	
DCLK Frequency	Fclk	-	51	-	MHZ
Horizontal display area	Thd	1024			Pixel
HSYNC	Th	20			Pixel
HSYNC blanking	Thbp+thfp	-	40	-	Pixel
Vertical display area	Tvd	768			Pixel
VSYNC	Th	2			Line
VSYNC blanking	Tvbp+tvfp	6	14	-	Line
Frequency	fV	-	60	-	Hz

Note: The DCLK range at last line of V-blanking should be set in 0-H-active/2.

4.2.2 Signal Timing waveforms of interface signal

Note: Please refer to JD9168 data sheet for more details.

For example: DOTCLK=51MHz;Frame Rate=60Hz;
 HA=1024,HFP=20,HBP=20,Hsync=20;
 VA=768,VFP=9,VBP=5,Vsync=2;

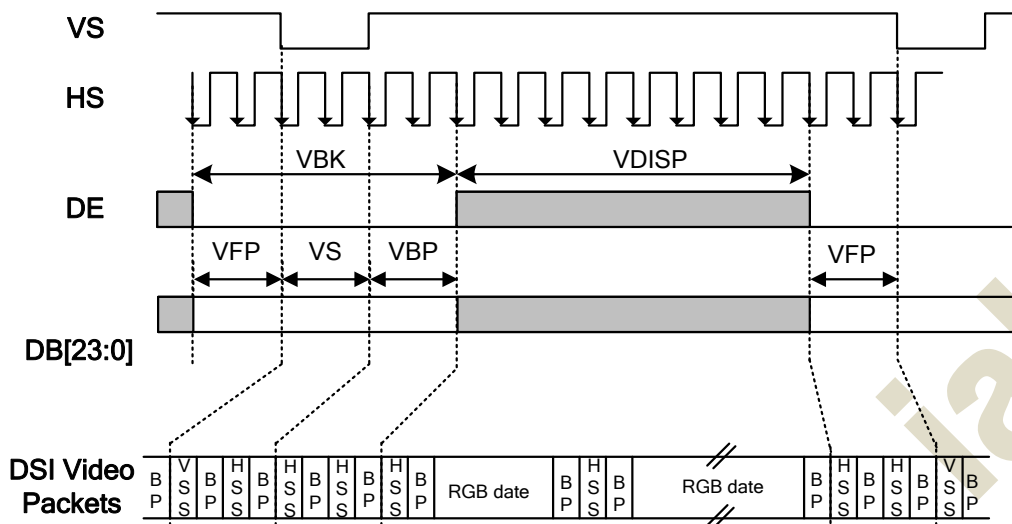

Figure 11.12: Vertical Timings for DPI I/F

Resolution=1024x600 (T_A=25°C, IOVCC=3.3V, VCI=3.3V)

Item	Symbol	Condition	Min.	Typ.	Max.	Unit
Vertical low pulse width	VS	-	2	-	Note ⁽¹⁾	Line
Vertical front porch	VFP	-	2	-	-	Line
Vertical back porch	VBP	-	2	-	Note ⁽¹⁾	Line
Vertical blanking period	VBL	VS+VBP+VFP	6	-	-	Line
Vertical active area	-	VDISP	-	600	-	Line
Vertical Refresh rate	VRR	-	-	60	-	Hz

Note:

1. The VS and VBP pulse width are related to GIP start pulse and GIP clock pulse timing. The GIP start pulse and GIP clock pulse must be set at corresponding position for LCD normal display.

Table 11.16: Vertical Timings for DSI Video I/F

Horizontal Timings

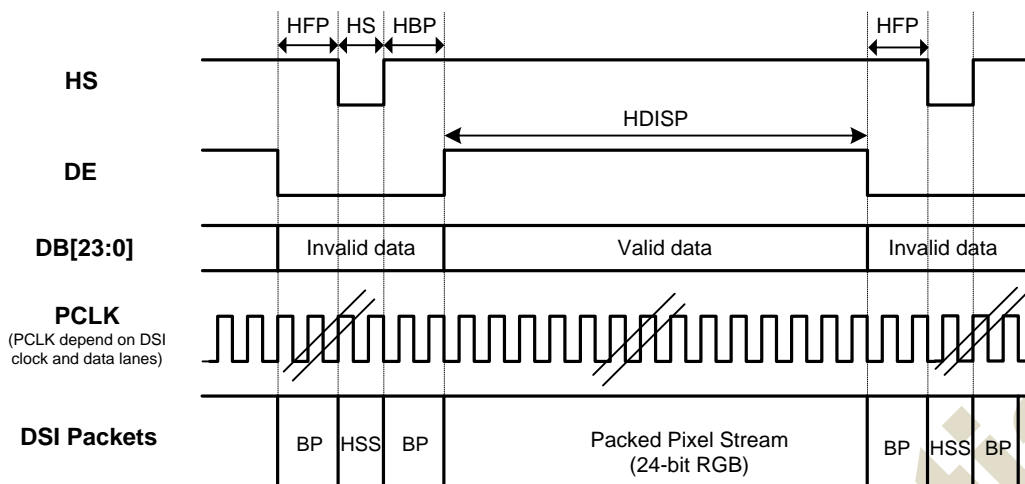

Figure 11.13: Horizontal Timing for DSI Video mode I/F

RGB Resolution=1024x600 (T_A=25°C, VCCH=IOVCC=3.3V, VCI=3.3V)

Item	Symbol	Condition	Min.	Typ.	Max.	Unit
HS low pulse width	HS	-	100	-	-	ns
Horizontal back porch	HBP	-	100	-	-	ns
Horizontal front porch	HFP	-	400	-	-	ns
Horizontal blanking period	HBLK	HS+HBP+HFP	-	900 ⁽¹⁾	-	ns
Horizontal active area	HDISP	1024 pixels	-	12 ⁽²⁾	-	us

Note:

1. Below time limitation will apply in all DSI speed range.

(1) HS+HBP >= 500ns.

(2) HFP >= 400ns.

2. Base on frame rate = 60HZ,

(1) VS=2, VBP=2 and VFP=2.

Table 11.17: Horizontal Timings for DSI Video mode I/F

4.2.3 Power Sequence

To prevent at latch-up or DC operation of the LCD module, the power on/off sequence shall be as shown in below.

Power on sequence – DSI:

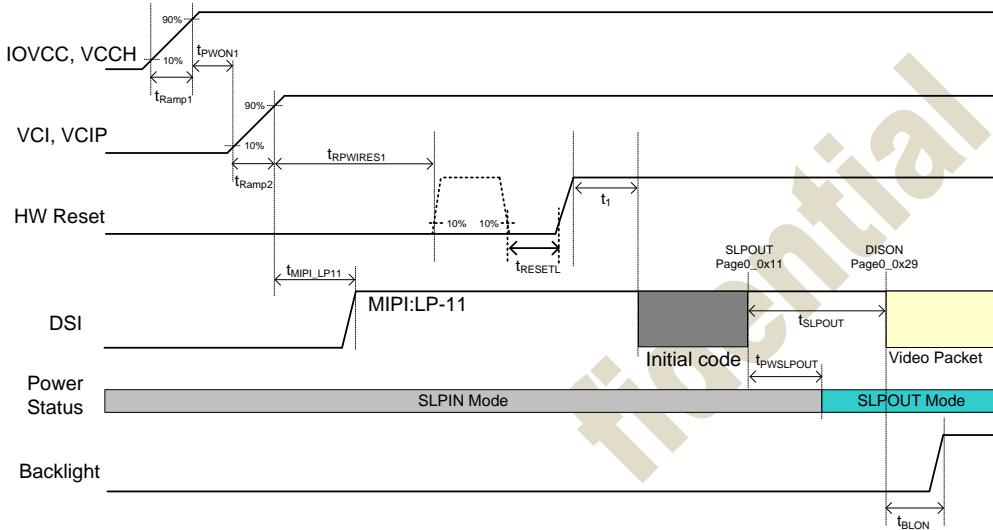

Power off sequence – DSI:

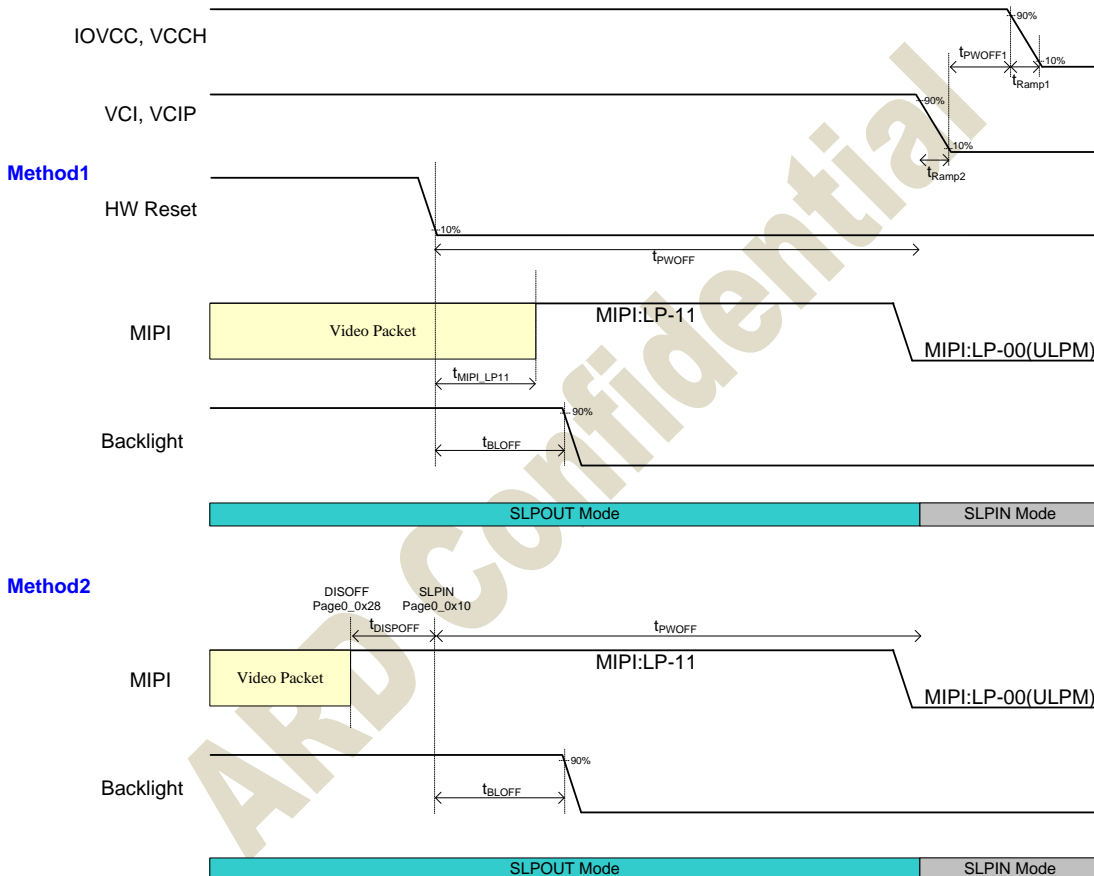

5. Pin Define

FPC connector customers can choose suitable suppliers according to their needs, as long as they meet the standard of 0.5mm pitch.

No.	Symbol	Function Description
1-2	LEDK2-K1	LED backlight(cathode)
3	LEDA	LED backlight(anode)
4	GND	Ground
5	D0N	Mimi Data
6	D0P	Mimi Data
7	GND	Ground
8	D1N	Mimi Data
9	D1P	Mimi Data
10	GND	Ground
11	CLKN	MIPI Clock
12	CLKP	MIPI Clock
13	GND	Ground
14	D2N	Mimi Data
15	D2P	Mimi Data
16	GND	Ground
17	D3N	Mimi Data
18	D3P	Mimi Data
19	GND	Ground
20	RESET	SYSTEM reset pin
21	STBYB/NC	Control standby or normal mode of LCM;If not use,let it open.
22	IOVCC	Power supply for the I/O circuit.
23	VCI	Power supply
24	VCI	Power supply
25	TP_GND/GND	TP Ground pin,connected to LCM ground pin.
26	TP_SCL	I2C clock input for TP.(If TP is connected)
27	TP_SDA	I2C data input and output for TP. (If TP is connected)
28	TP_RESET	TP reset pin. (If TP is connected)
29	TP_INT	External interrupt to the host for TP. (If TP is connected)
30	TP_VCI	TP Voltage power. (If TP is connected)

6. Backlight Characteristics

Item	Symbol	Condition	Min	Typ	Max	Unit	Note
Forward voltage	V _f	I _f =24mA	32.4	34.8	37.2	V	Note1
Forward current	I _{Led}	-	-	24	-	mA	
Number of LED	--	--		12		pcs	
Life Time	--	--	10000	20000	--	Hrs	Note3
Connection mode	S	--	2 Parallel/6 Serial			--	

Note 1: I_f is defined for one channel LED. There are total four LED channels in back light unit

To avoid the individual difference of LED, CC driving mode is strongly recommended

Note 2: Optical performance should be evaluated at T_a=25°C only.

Note 3: I_f LED is driven by high current , high ambient temperature & humidity condition. The life time of LED Will be reduced. Operating life means brightness goes down to 50% initial brightness. Typical operating Life Time is estimated data.

LED CIRCUIT DIAGRAM:

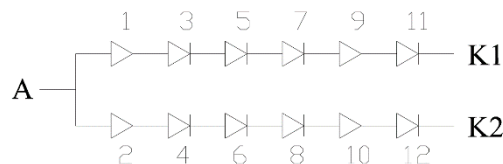

$$32.4V < V_f < 37.2V, V_{Led} = 5.8V$$

$$I_f = 28 \text{ mA}$$

7. Optical Characteristics

(Contrast, RT, viewing angle results are using CPT LC+ EWV Polarizer+ CPT's BLU (2L1D) reference only.) (Note1)

Item	Symbol	Condition	Min	Typ	Max	Unit	Note	
Brightness	Bp	$\theta=0^\circ, \Phi=0^\circ$	--	300	--	Cd/m ²	2	
Contrast Ratio	CR		400	600	--	--	3	
Response Time	Tr+Tf	$\theta=0^\circ, \Phi=0^\circ$	--	25	35	ms	4	
Viewing Angle	Vertical	U	--	CR \geq 10	70	80	--	Deg
		D	--		70	80	--	
	Horizontal	L	--		70	80	--	Deg
		R	--		70	80	--	
Color Filter Chroma-cicity	<i>If need more information pls contact</i>							

Note: The parameter is slightly changed by temperature, driving voltage and material

Note 1. Ambient condition: 25°C \pm 2°C, 60 \pm 10%RH, under 10 Lux in the darkroom

Note 2. The data are measured after LEDs are turned on for 5 minutes. LCM displays full white. The brightness is the average value. Measurement equipment BM-7(TOPCON) (Φ 8mm)

Measuring condition:

- Measuring surroundings: Dark room.
- Measuring temperature: Ta=25°C.
- Adjust operating voltage to get optimum contrast at the center of the display.

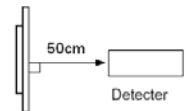

Measured value at the center point of LCD panel after more than 5 minutes while backlight turning on

Note 3. Definition of Contrast Ratio: CR=White Luminance(ON)/Black Luminance(OFF)

Note 4. Definition of response time: The response time is defined as the time interval between the 10% and 90% amplitudes.

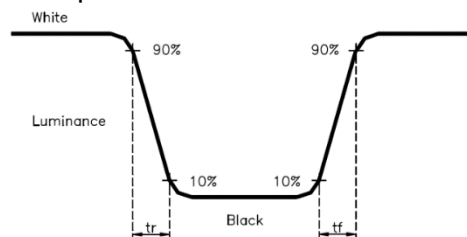

Note 5. Definition of view angle(θ, Φ)

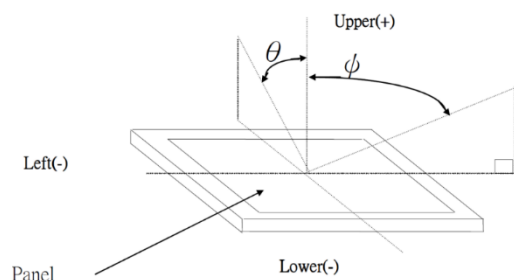

8. Reliability Test items and Criteria

No	Test Item	Test Condition	Criterion
1	High Temperature Storage	70°C;240hrs	1. After testing, cosmetic and electrical defects should not happen. 2. Total current consumption should not be more than twice of initial value.
2	Low Temperature Storage	-20°C;240hrs	
3	High Temperature Operation	60°C;240hrs	
4	Low Temperature Operation	-10°C;240hrs	
5	Hight Temperature and High Humidity Operation	60°C,90%RH;240hrs	
6	Thermal Shock	-20°C+70°C,0.5Hr;200cycles	Not allowed cosmetic and electrical defects.
7	Vibration Test	10Hz~150Hz,100m/s ² ,120min	
8	Shock Test	Half-sine wave,300m/s ² ,11ms	

- Note:**
1. All judgement of display are performed after temperature of panel return to room temperature.
 2. Display function should be no change under normal operating condition.
 3. Under no condensation of dew.
 4. only guarantee the above
 - 5 test items, and without guarantee the others.

9. Inspection Certeria

9.1 Classification of defects

Major defects (MA): A major defect refers to a defect that may substantially degrade usability for product applications, including all functional defects(such as no display, abnormal display, open or missing segment, short circuit, missing component), outline dimension beyond the drawing, progressive defects and those affecting reliability.

Minor defects (MI): A minor defect refers to a defect which is not considered to be able to substantially degrade the product application or a defect that deviates from existing standards almost unrelated to the effective use of the product or its operation, such as black spot, white spot, bright spot, pinhole, black line, white line, contrast variation, glass defect, polarizer defect, etc.

9.2 Definition of inspection range

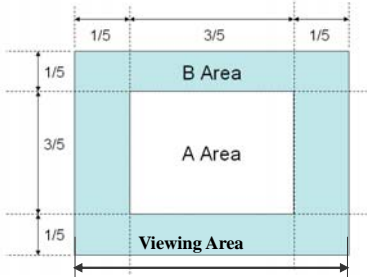
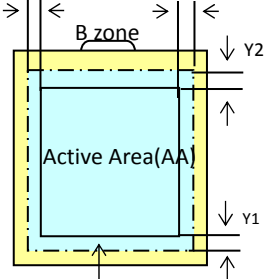
<p>For dot defect of TFT LCD which is not smaller than 3 inches, dividing three areas to make a judgment (according to figure 1).</p> <p>A area : center of viewing area B area : periphery of viewing area C area : Outside viewing area</p> <p>For other defects, dividing two areas to make a judgment (according figure 2).</p> <p>A zone : Inside Viewing area B zone : Outside Viewing area</p> <p>X1(A.A~V.A): 2mm X2(A.A~V.A): 2mm Y1(A.A~V.A): 2mm Y2(A.A~V.A): 2mm</p>	 <p>Figure 1</p>	 <p>Figure 2</p>
--	--	---

9.3 Inspection items and general notes

General notes	<p>Should any defects which are not specified in this standard happen, additional standard shall be determined by mutual agreement between customer and</p> <p>Viewing area should be the area which guarantees.</p> <p>Limit sample should be prior to this Inspection standard.</p> <p>Viewing judgment should be under static pattern.</p> <p>Inspection conditions</p> <p>Inspection distance: 250 mm (from the sample) Temperature : 25±5 °C</p> <p>Inspection angle : 45 degrees in 6 o'clock direction (all defects in viewing area should be inspected from this direction)</p>	
Inspection items	Pinhole, Bright spot, Black spot, White spot, Black line, White Line, Foreign particle, Bubble	The color of a small area is different from the remainder. The phenomenon doesn't change with voltage
	Contrast variation	The color of a small area is different from the remainder. The phenomenon changes with voltage
	Polarizer defect	Scratch, Dirt, Particle, Bubble on polarizer or between polarizer and glass
	Dot defect (TFT LCD)	The pixel appears bright or dark abnormally when display
	Functional defect	No display, Abnormal display, Open or missing segment, Short circuit, False viewing direction
	Glass defect	Glass crack, Shaved corner of glass, Surplus glass
	PCB defect	Components assembly defect

9.4 Outgoing Inspection level

Outgoing Inspection standard	Inspection conditions	Inspection				
		Min.	Max.	Unit	IL	AQL
Outline Dimension	See 13: Outline Drawing	See 11			II	0.065
Position finding Dimension Assemble Dimension	See 13: Outline Drawing	See 11			II	0.065

Note: Sampling standard conforms to GB2828

9.5 Inspection Items and Criteria

Inspection items	Judgment standard		
	Category	Acceptable number	
		A zone	B zone

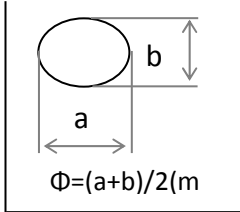
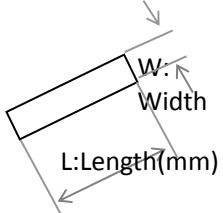
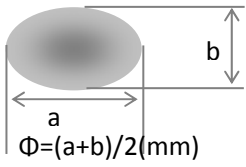
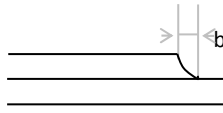
1	Black spot, White spot, Pinhole, Foreign Particle, Particle in or on glass, Scratch on glass		A	$\Phi \leq 0.10$	Neglected	Neglected
			B	$0.10 < \Phi \leq 0.2$	1	
			C	$0.2 < \Phi$	0	
			D	-	-	
			Total defective point(B,C)		1	
2	Black line, White line, and Particle Between Polarizer and glass, Scratch on glass		A	$W \leq 0.02$	Neglected	Neglected
			B	$0.02 < W \leq 0.03$ $L \leq 1.0$	1	
			C	$0.03 < W \leq 0.05$ $L > 1.0$	0	
			D	$0.05 < W, 1.0 < L$	0	
			Total defective point(B,C)		1	
3	Bright spot		$0.5 \text{ Dot} < \Phi$	none	none	
4	Contrast variation		A	$\Phi < 0.2$	Neglected	Neglected
			B	$0.2 < \Phi \leq 0.3$	2	
			C	$0.3 < \Phi \leq 0.4$	1	
			D	$0.4 < \Phi$	0	
			Total defective point(B,C)		3	
5	Bubble inside cell		any size	none	none	
6	Polarizer defect (if Polarizer is used)	Scratch ,damage on polarizer, Particle on polarizer or between polarizer and glass.	Refer to item 1 and item 2.			
		Bubble, dent and convex	A	$\Phi \leq 0.1$	Neglected	Neglected
			B	$0.1 < \Phi \leq 0.2$	1	
			C	$0.2 < \Phi$	0	
7	Surplus glass		$B \leq 0.3\text{mm}$			

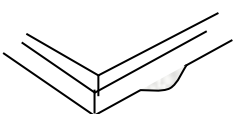
		Surrounding surplus glass 	Should not influence outline dimension and assembling.
8	Open segment or open common		Not permitted
9	Short circuit		Not permitted
10	False viewing direction		Not permitted
11	Contrast ratio uneven		According to the limit specimen
12	Crosstalk		According to the limit specimen
13	Black /White spot(display)		Refer to item 1
14	Black /White line(display)		Refer to item 2

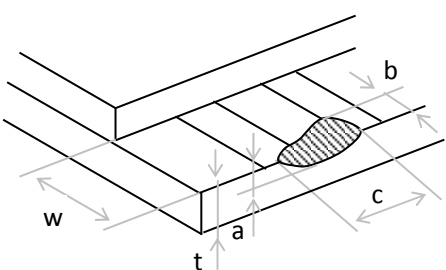
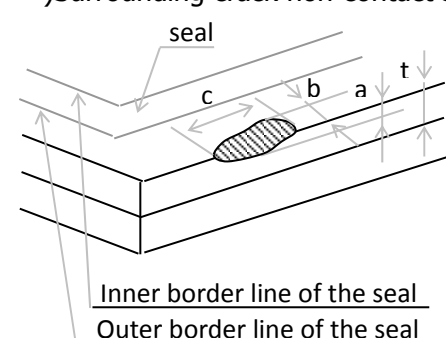
Inspection items		Judgment standard		Acceptable number	
		Category(application: B zone)			
15	Glass defect crack	i)The front of lead terminals 	A	$a \leq t, b \leq 1/5W, c \leq 3\text{mm}$	Max.3 defects allowed
			B	Crack at two sides of lead terminals should not cover patterns and alignment mark	
	ii)Surrounding crack-non-contact side 			$b < \text{Inner borderline of the seal}$	

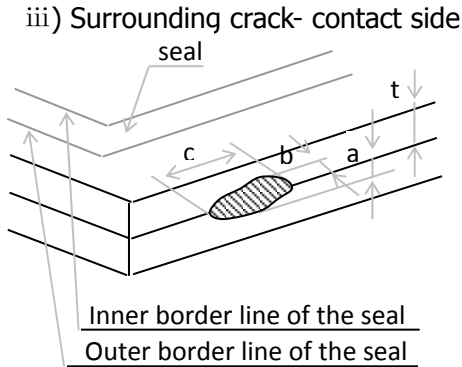
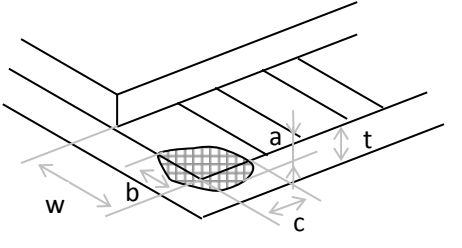
		<p>iii) Surrounding crack- contact side seal</p> 	<p>$b < \text{Outer borderline of the seal}$</p>	
		<p>iv) Corner</p> 	<p>A $a \leq t, b \leq 3.0, c \leq 3.0$</p> <p>B Glass crack should not cover patterns u and alignment mark and patterns.</p>	

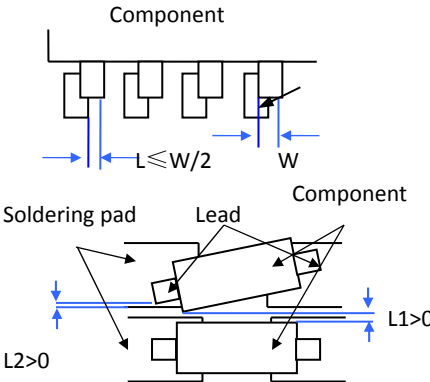
Inspection items		Judgment standard
		Category(application: B zone)
16	PCB defect	<p>Component soldering: No cold soldering, short, open circuit, burr, tin ball The flat encapsulation component position deviation must be less than 1/3 width of the pin (Pic.1); the sheet component deviation: Pin deviates from the pad and contact with the near components is not permitted (Pic.2)</p>  <p>lead defect: The lead lack must be less than 1/3 of its width; The lead burr must be less than 1/3 of the seam; Impurities connect with the near leads is not permitted</p>

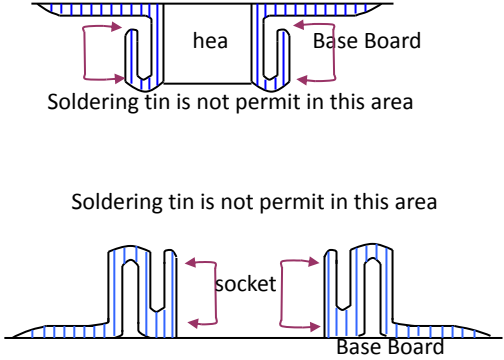
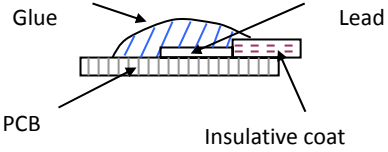
	<p>Connector soldering: Soldering tin is at contact position of the plug and socket is not permitted No foundation is scald Serious cave distortion on plug and socket contact pin is not permitted</p>	
	<p>Glue on root of the speaker receiver and motor lead: The insulative coat of the lead must join into the PCB; the protected glue must envelop to the insulative coat.</p>	

10. Precautions for Use of LCD Modules

10.1 Handling Precautions

- 10.1.1** The display panel is made of glass. Do not subject it to a mechanical shock by dropping it from a high place, etc.
- 10.1.2** If the display panel is damaged and the liquid crystal substance inside it leaks out, be sure not to get any in your mouth, if the substance comes into contact with your skin or clothes, promptly wash it off using soap and water.
- 10.1.3** Do not apply excessive force to the display surface or the adjoining areas since this may cause the color tone to vary.
- 10.1.4** The polarizer covering the display surface of the LCD module is soft and easily scratched. Handle this polarizer carefully.
- 10.1.5** If the display surface is contaminated, breathe on the surface and gently wipe it with a soft dry cloth. If still not completely clear, moisten cloth with one of the following solvents:
- Isopropyl alcohol
 - Ethyl alcohol
- Solvents other than those mentioned above may damage the polarizer. Especially, do not use the following:
- Water
 - Ketone
 - Aromatic solvents
- 10.1.6** Do not attempt to disassemble the LCD Module.
- 10.1.7** If the logic circuit power is off, do not apply the input signals.
- 10.1.8** To prevent destruction of the elements by static electricity, be careful to maintain an optimum work environment.
- a. Be sure to ground the body when handling the LCD Modules.
 - b. Tools required for assembly, such as soldering irons, must be properly ground.
 - c. To reduce the amount of static electricity generated, do not conduct assembly and other work under dry conditions.
 - d. The LCD Module is coated with a film to protect the display surface. Be care when peeling off this protective film since static electricity may be generated.

10.2 Storage precautions

- 10.2.1** When storing the LCD modules, avoid exposure to direct sunlight or to the light of fluorescent lamps.
- 10.2.2** The LCD modules should be stored under the storage temperature range. If the LCD modules will be stored for a long time, the recommend condition is:
- Temperature : 0°C ~ 35°C
Relatively humidity: ≤80%
- Remark:** If the LCD modules is covered with Touch Panel, in order to ensure the effectiveness of the protective film, its storage conditions are more harsh, the recommend condition is:
- Temperature : 20±5°C
Relatively humidity: 60%±10%RH
- 10.2.3** The LCD modules should be stored in the room without acid, alkali and harmful gas.

- 10.3** The LCD modules should be no falling and violent shocking during transportation, and also should avoid excessive press, water, damp and sunshine

