



深圳市宇华微科技有限公司

PRODUCT SPECIFICATION

Doc. Number:

- Tentative Specification
- Preliminary Specification
- Approval Specification

MODEL NO.: YH043ND25V.2

SUFFIX: L01

Customer:	
APPROVED BY	SIGNATURE
Name / Title _____	
Note :	

Please return 1 copy for your confirmation with your signature and comments .	

Approved By	Checked By	Prepared By
		MW Chen



Record of Revision

Version	Revise Date	Page	Content
Pre-spec .01	2022/01/15		Initial Release.

1. General Specifications

No.	Item	Specification	Remark
1	LCD size	4.3 inch(Diagonal)	
2	Driver element	a-Si TFT active matrix	
3	Resolution	480 × 3 (RGB) × 272	
4	Display mode	Normally White, Transmissive	
5	Dot pitch	0.066(W) × 0.198(H) mm	
6	Active area	95.04(W) × 53.856(H) mm	
7	Module size	105.5(W) × 67.2(H) × 2.90(D) mm	Note 1
8	Surface treatment	Anti-Glare	
9	Color arrangement	RGB-stripe	
10	DRIVER IC	ST7282/ILI6485	
11	Backlight Power consumption	0.6 W(Typ.)	
12	Panel Power consumption	0.06 W (Typ.)	
13	Weight	TBD (Typ.)	

Note 1: Refer to Mechanical Drawing.

2.BLOCK DIAGRAM:

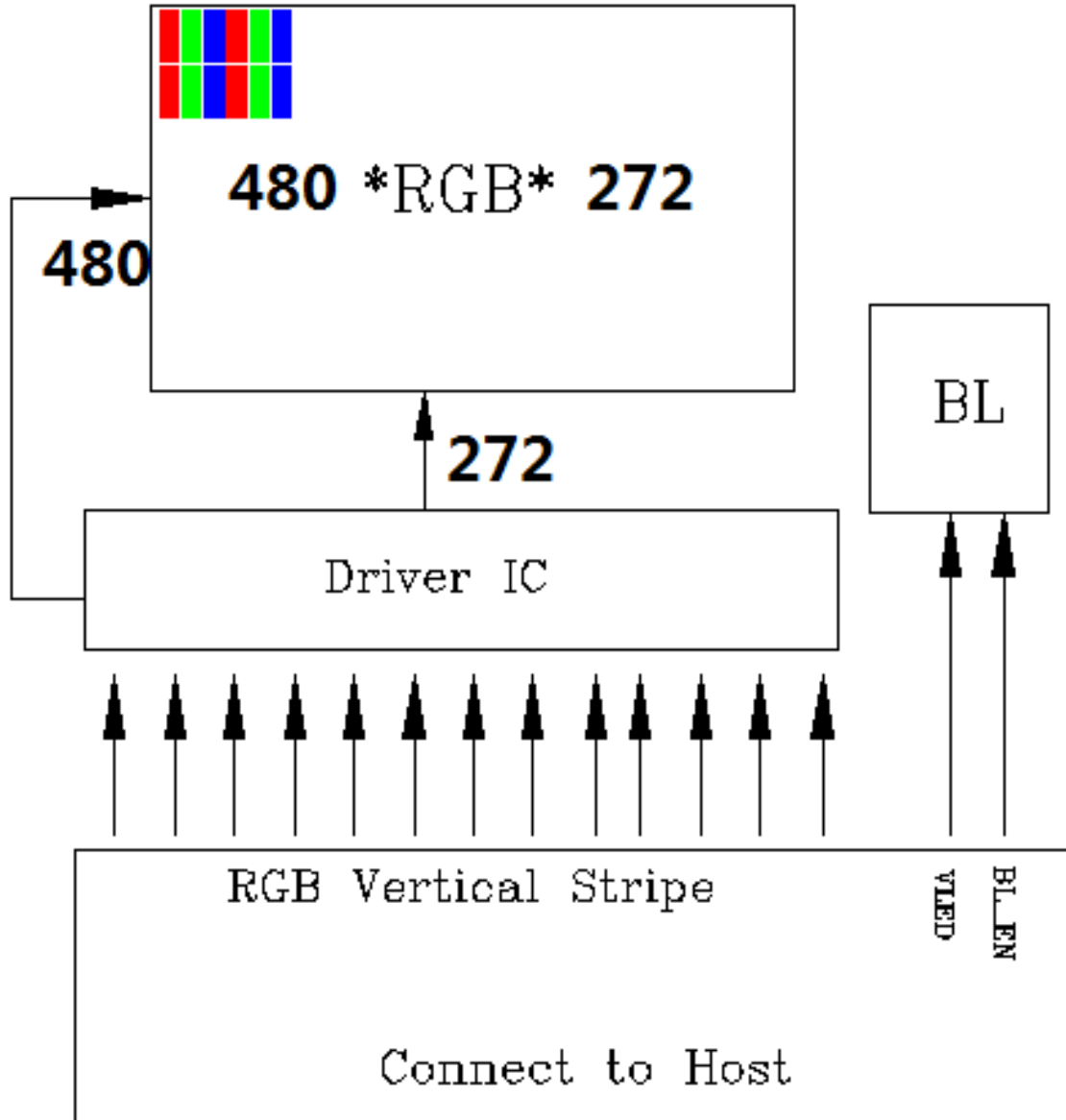

3.DIMENSION

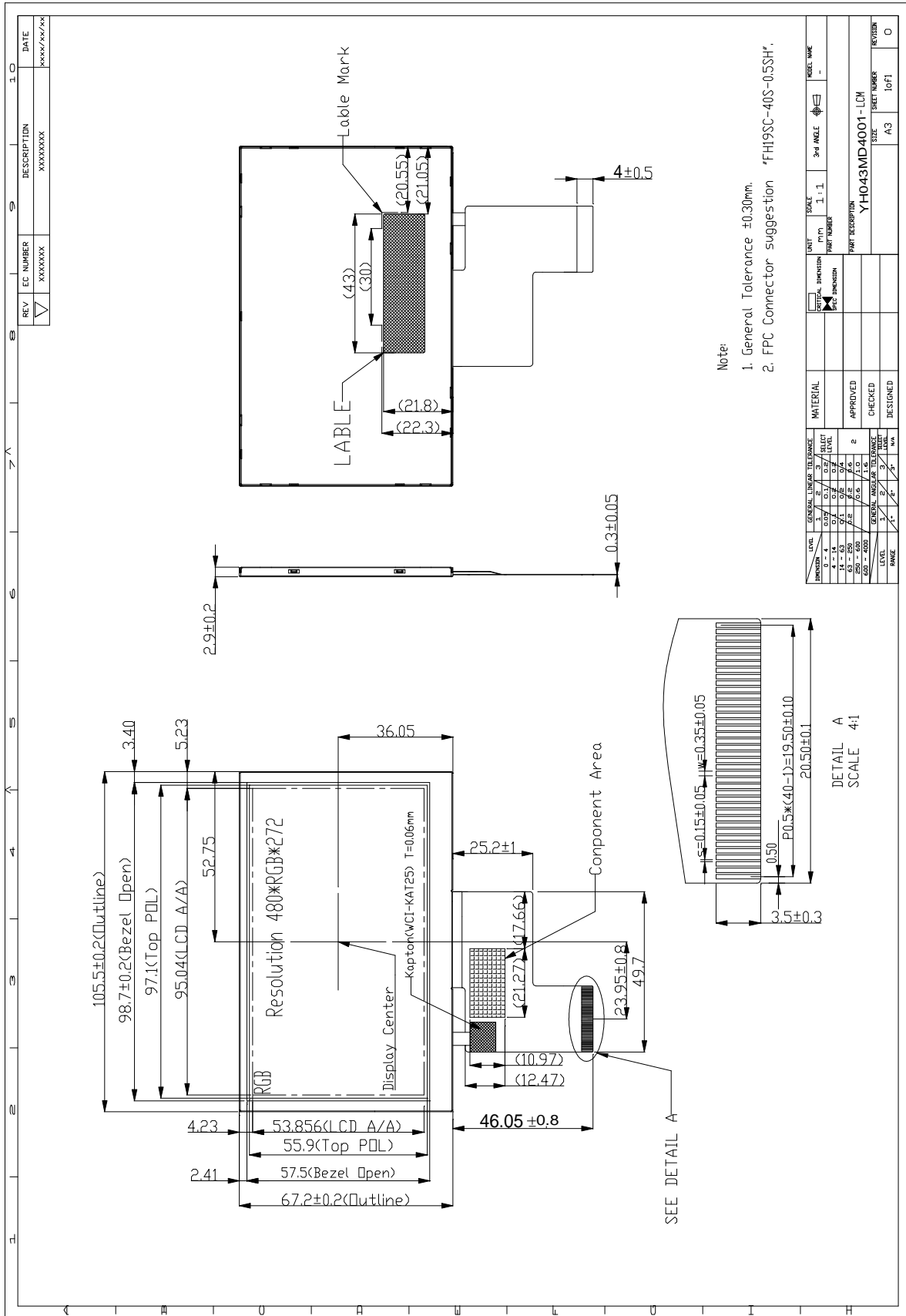

Note:
 1. General Tolerance ±0.30mm.
 2. FPC Connector suggestion "FH19SC-40S-0.5SH".

REV	EC NUMBER	DESCRIPTION	DATE
▽	XXXXXX	XXXXXXXXXX	XXXX/XX/XX

UNIT	SCALE	3rd ANGLE	MODEL NAME
MATERIAL	1:1	1:1	-
APPROVED	YH043MD4001-LCM		
CHECKED			
DESIGNED			

LEVEL	GENERAL TOLERANCE	LINEAR TOLERANCE	ANGULAR TOLERANCE	FORM TOLERANCE	POSITION TOLERANCE
0-4	0.15	0.1	0.5	0.1	0.1
5-8	0.2	0.15	0.6	0.15	0.15
9-12	0.3	0.2	0.8	0.2	0.2
13-15	0.4	0.3	1.0	0.3	0.3
16-20	0.5	0.4	1.2	0.4	0.4
21-25	0.6	0.5	1.5	0.5	0.5
26-30	0.8	0.7	2.0	0.7	0.7
31-40	1.0	0.9	2.5	0.9	0.9
41-50	1.2	1.1	3.0	1.1	1.1
51-60	1.5	1.4	4.0	1.4	1.4
61-70	2.0	1.8	5.0	1.8	1.8
71-80	2.5	2.3	6.0	2.3	2.3
81-90	3.0	2.8	8.0	2.8	2.8
91-100	4.0	3.6	10.0	3.6	3.6

DETAIL A
SCALE 4:1



YHW DISPLAY

深圳市宇华微科技有限公司

4. PIN DESCRIPTION:

FPC Connector is used for the module electronics interface. The recommended model is "FH19SC-40S-0.5SH" manufactured by HIROSE.

Pin No.	Symbol	I/O	Function	Remark
1	V _{LED-}	P	Power for LED backlight cathode	
2	V _{LED+}	P	Power for LED backlight anode	
3	GND	P	Power ground	
4	V _{DD}	P	Power voltage	
5	R0	I	Red data (LSB)	
6	R1	I	Red data	
7	R2	I	Red data	
8	R3	I	Red data	
9	R4	I	Red data	
10	R5	I	Red data	
11	R6	I	Red data	
12	R7	I	Red data (MSB)	
13	G0	I	Green data (LSB)	
14	G1	I	Green data	
15	G2	I	Green data	
16	G3	I	Green data	
17	G4	I	Green data	
18	G5	I	Green data	
19	G6	I	Green data	
20	G7	I	Green data (MSB)	

21	B0	I	Blue data (LSB)	
22	B1	I	Blue data	
23	B2	I	Blue data	
24	B3	I	Blue data	
25	B4	I	Blue data	
26	B5	I	Blue data	
27	B6	I	Blue data	
28	B7	I	Blue data (MSB)	
29	GND	P	Power ground	
30	CLK	I	Pixel clock	
31	DISP	I	Display on/off	
32	NC	-	No connection	
33	NC	-	No connection	
34	DE	I	Data Enable	
35	NC	-	No connection	
36	GND	P	Power ground	
37	NC	-	No connection	
38	NC	-	No connection	
39	NC	-	No connection	
40	NC	-	No connection	

I: input, O: output, P: Power

5.ELECTRICAL CHARACTERISTICS

5.1 Absolute Maximum Ratings

Item	Symbol	Values		Unit	Remark
		Min	Max.		
Digital supply voltage	VDDIO	-0.3	4.5	V	
Power Supply for Pump	VD	-0.3	4.5	V	
Analog supply voltage	VDD2	-0.3	7.0	V	

Note: Stresses beyond those given in the Absolute Maximum Rating table may cause operational errors or damage to the device. For normal operational conditions see AC/DC Electrical Characteristics

5.2DC Characteristics

5.2.1 Operating Conditions

Item	Symbol	Values			Unit	Conditions
		Min	Typ.	Max.		
Charge Pump Supply	PVDD	3	3.3	3.6	V	PWR_SEL=H
Digital Supply Voltage	VDD	3	3.3	3.6	V	PWR_SEL=H
Digital Interface Supply Voltage	VDDIO	1.8	-	VDD	V	
Digital Input Voltage	Din	0	-	VDDIO	V	
OTP Supply Voltage	V_OTP	-	6	-	V	
VCOM AC Voltage	VCOMH-VCOML	2.96	-	6.2	V	

5.2.2 DC Characteristics for Digital Circuit

Item	Symbol	Values			Unit	Conditions
		Min	Typ.	Max.		
Low Level Input Voltage	Vil	GND	-	0.3xVDDIO	v	
High Level Input	Vih	0.7xVDDIO	-	VDDIO	V	
High Level output Voltage	Voh	VDDIO-0.4	-	VDDIO	V	
Low Level Output	Vol	GND	-	GND+0.4	V	
Input Leakage Current	Iil	-	-	1.0	mA	
Pull High/Low Resistor	Rp	-	100K	-	Ohm	

5.2.3 DC Characteristics for Analog Circuit

$VDDIO=1.8V$, $VDD = 3.3V$, $AVDD = 6V$, $AGND = 0V$, $TA = -20^{\circ}C$ to $70^{\circ}C$

Item	Symbol	Values			Unit	Conditions
		Min	Typ.	Max.		
Analog Supply	VDD2	-	5	-	V	
Positive High-voltage	VGH	9	15	16	V	No Load. By VGH_SEL setting.
Negative High-voltage	VGL	-11	-10	-7	V	No Load. By VGL_SEL setting.
VCOMH Output Level	VCOM	2.46	-	5	V	By VCOMH setting.
VCOML Output Level	VCOM	-3	-	-0.46	V	By VCOML setting
Output Voltage Deviation	Vod	-	± 20	± 35	mV	$VO = 0.15V \sim 0.5V$, $3.45V \sim 3.8V$
		-	± 15	± 20		$VO = 0.5V \sim 3.45V$
Output Dynamic	Vdr	0.1	-	AVDD-0.1		S1 to S720
VCOM Low Level Output	IOLC	-	-10	-	mA	VCOM AC output =0.5V
VCOM High Level Output Current	IOHC	-	-10	-	mA	VCOM AC output =5.7V
Analog Standby	Iast	-	-	20	μA	
Analog Operation	IDD	-	5.0	-	mA	Without panel loading

5.3 DC BackLight Unit

Item	Symbc	Min	Typ	Max	Unit	Remark
Chromaticity Coordinates	X	0.234	0.284	0.334		$IF=20mA$
	Y	0.303	0.353	0.403		$IF=20mA$
Forward Voltage	VF		30	34	V	$IF=20mA$
Reverse Current	IR			50	μA	$VR=20V, 1LED$
Luminous Tolerance	IV-M	75			%	$(MIN/MAX) \times 100$
Power Dissipation	Pd	600			mW	
Peak Forward Current	I _{fp}	20			mA	
Reverse Voltage	VR	50			V	
Life time	L	30000	-	-	Hrs	

5.3.1 Internal Circuit Diagram

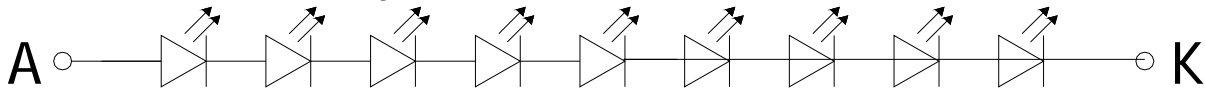

B/L CIRCUIT DIAGRAM

9 PCS WHITE LED; $I_F = 20\text{mA}$, $V_F = 27\text{V}$

5.4 POWER SEQUENCE

Power On Sequence

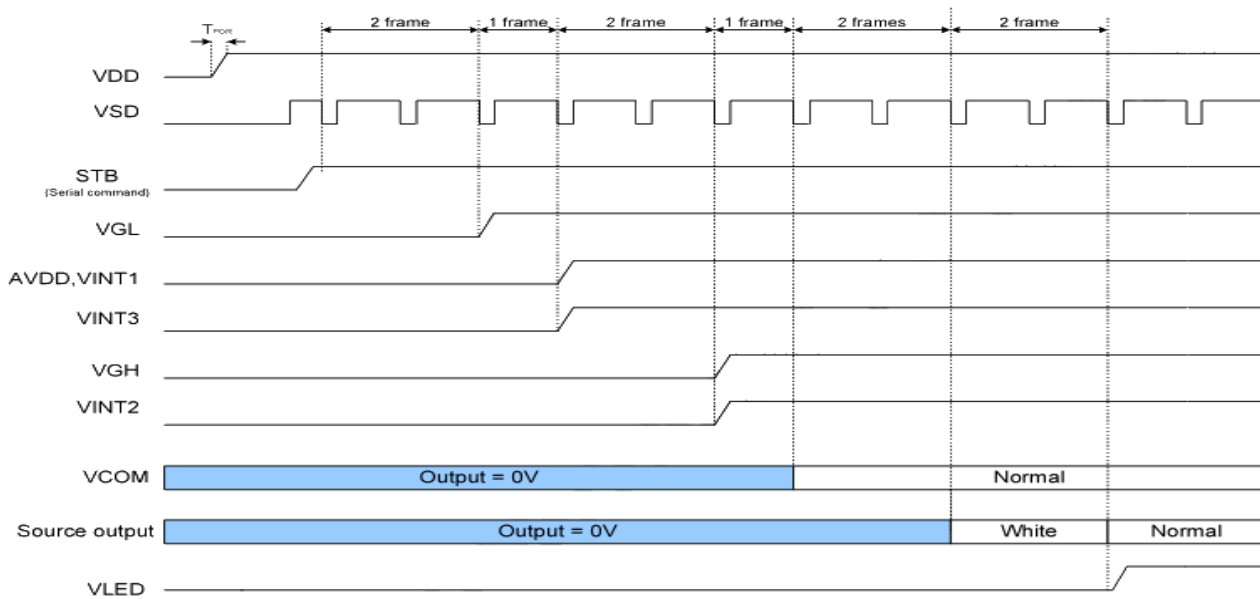

Power Off Sequence

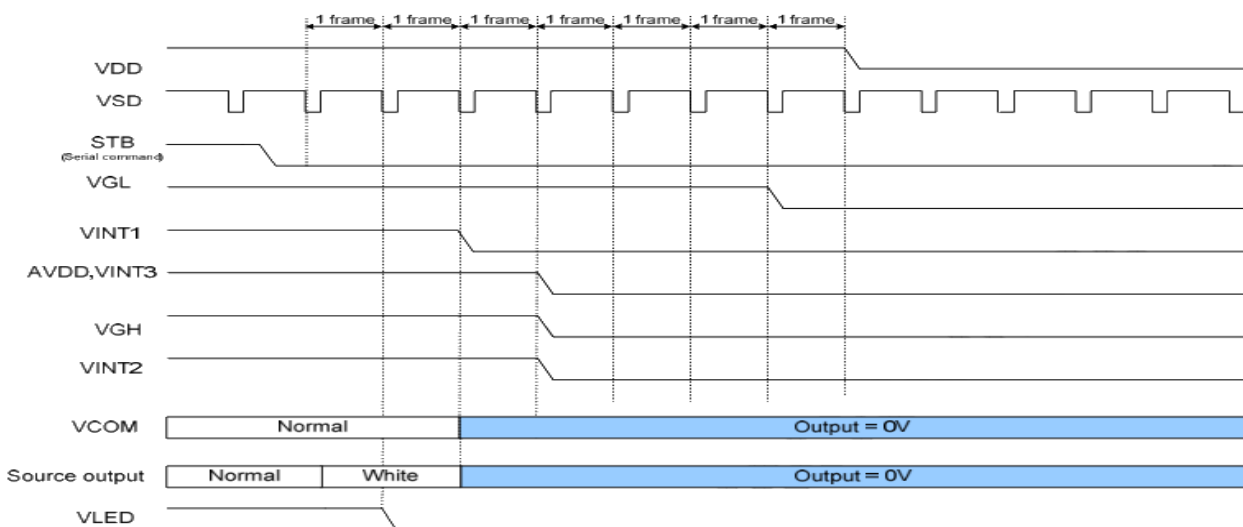

Note:

- When normally-black LC is used, please send black pattern to discharge the panel.
- When normally-white LC is applied, please send white pattern to discharge the pane

6. INPUT SIGNAL TIMING

6.1 AC Characteristics

$VDDIO=1.8V$, $VDD = 3.3V$, $AVDD = 6V$, $AGND = 0V$, $TA = -20^{\circ}C$ to $70^{\circ}C$

Item	Symbol	Min.	Typ.	Max.	Unit	Note
<i>CLK pulse duty</i>	<i>T_{cw}</i>	40	50	60	%	
<i>Hsync width</i>	<i>T_{hw}</i>	1.0	-	-	DCLK	
<i>Hsync period</i>	<i>T_h</i>	55	60	65	us	
<i>Vsync setup time</i>	<i>T_{vst}</i>	12	-	-	ns	
<i>Vsync hold time</i>	<i>T_{vhd}</i>	12	-	-	ns	
<i>Hsync setup time</i>	<i>T_{hst}</i>	12	-	-	ns	
<i>Hsync hold time</i>	<i>T_{hhd}</i>	12	-	-	ns	
<i>Data set-up time</i>	<i>T_{dsu}</i>	12	-	-	ns	
<i>Data hold time</i>	<i>T_{dhd}</i>	12	-	-	ns	
<i>DE set-up time</i>	<i>T_{desu}</i>	12	-	-	ns	
<i>DE hold time</i>	<i>T_{dehd}</i>	12	-	-	ns	
<i>SD output stable time</i>	<i>T_{st}</i>	-	10	12	us	
<i>GD output rise and fall time</i>	<i>T_{gst}</i>	-	500	1000	ns	
<i>Serial communication</i>						
<i>Delay between CSB and Vsync</i>	<i>T_{cv}</i>	1			us	
<i>CS input setup time</i>	<i>T_{s0}</i>	50			ns	
<i>Serial data input setup time</i>	<i>T_{s1}</i>	50			ns	
<i>CS input hold time</i>	<i>T_{h0}</i>	50			ns	
<i>Serial data input hold time</i>	<i>T_{h1}</i>	50			ns	
<i>SCL pulse high width</i>	<i>T_{wh1}</i>	50			ns	
<i>SCL pulse low width</i>	<i>T_{w11}</i>	50			ns	
<i>CS pulse high width</i>	<i>T_{w2}</i>	400			ns	

6.2 AC Timing Diagram

6.2.1 Clock and Data Input Timing Diagram

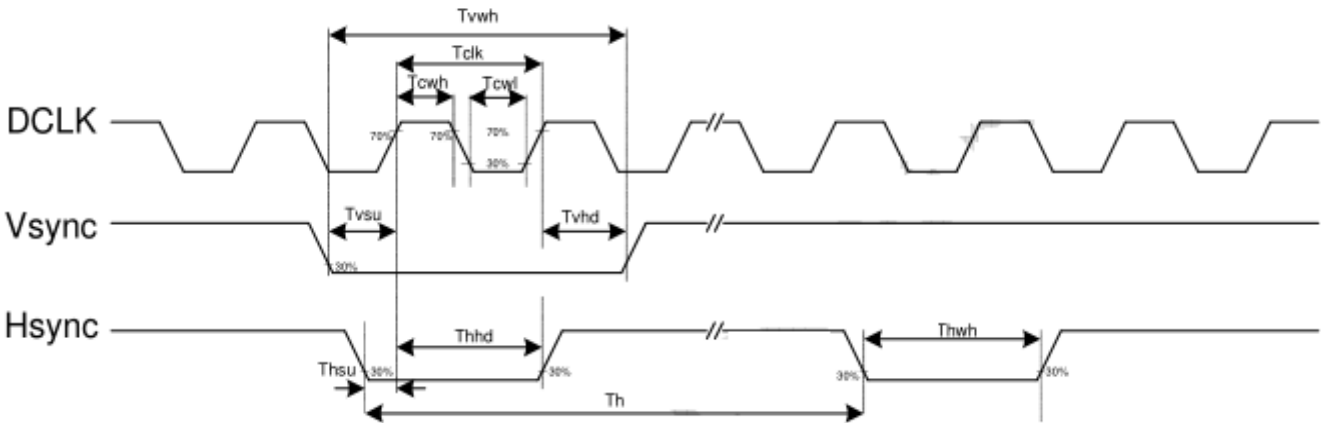
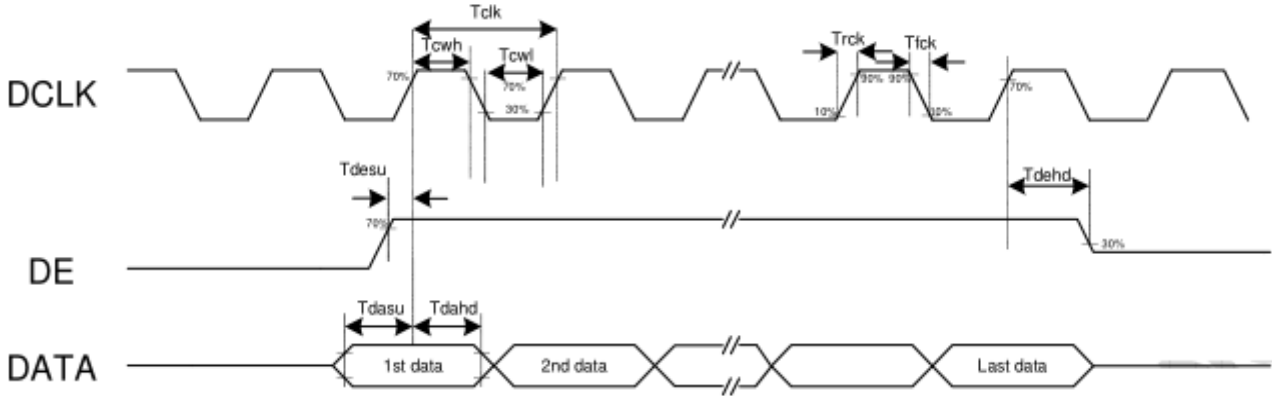

6.2.2 3-wire communication timing diagram

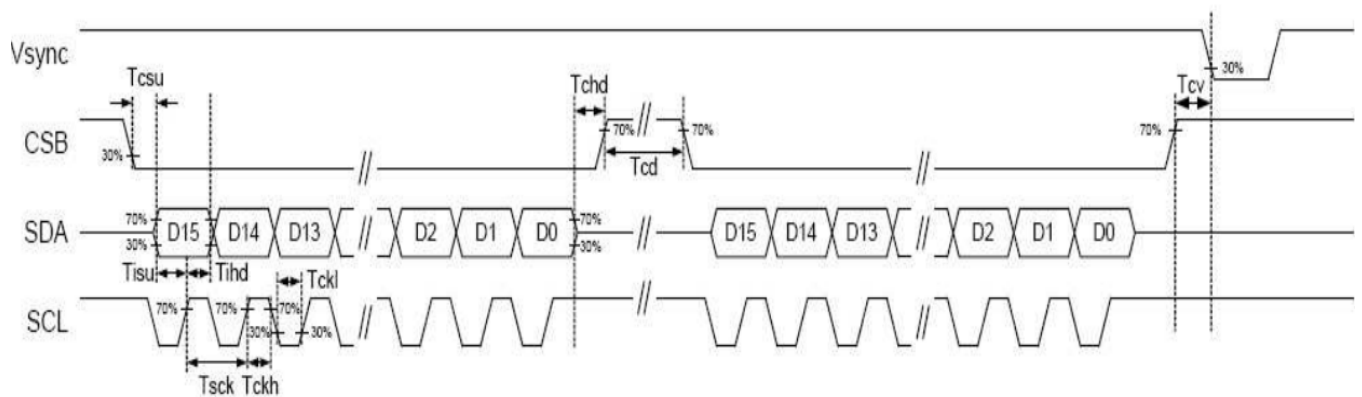

6.3 Parallel RGB Data Format

6.3.1 Parallel RGB Input Timing Table

Item	Symbol	Min.	Typ.	Ma	Unit	Note	
DCLK Frequency	F_{clk}	5	9	12	MHz		
DCLK Period	T_{clk}	83	110	200	ns		
Hsync	Period Time	T_h	490	531	605	DCLK	
	Display Period	T_{hd}		480		DCLK	
	Back Porch	T_{hbp}	36	40	255	DCLK	By H_BLANKING Setting
	Front Porch	T_{hfp}	4	5	65	DCLK	
	Pulse Width	T_{hw}	1			DCLK	
Vsync	Period Time	T_v	277	288	400	H	
	Display Period	T_{vd}		272		H	
	Back Porch	T_{vbp}	3	8	31	H	By V_BLANKING setting
	Front Porch	T_{vfp}	2	8	97	H	
	Pulse Width	T_{vw}	1	10		H	

6.3.2 Parallel RGB Mode Data format

(HV Mode)

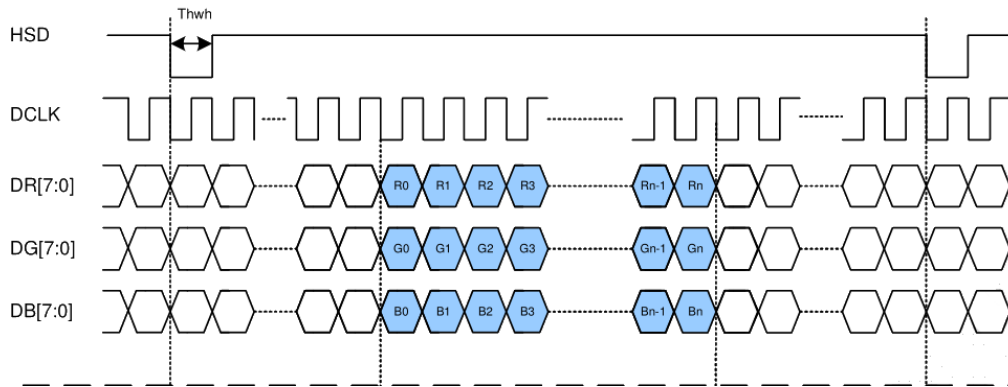

(DE Mode)

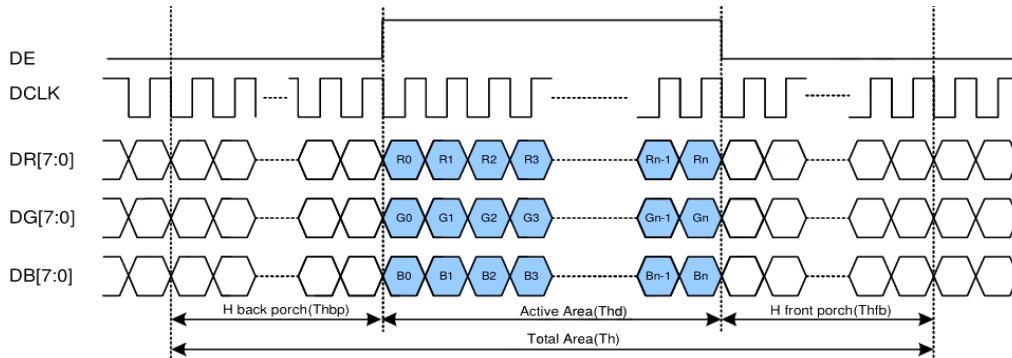

7. OPTICAL CHARACTERISTICS

Item	Symbol	Condition	Min.	Typ.	Max.	Unit	Note
Contrast Ratio	CR	*1)	-	500	-	-	Note 3
Brightness	B		-	450	-	cd/m ²	
Response Time	Tr+ Tf	*3)	-	25	50	ms	Note 4
Color Filter Chromacicity with C light	White	x	$\theta = \Phi = 0^\circ$	0.234	0.284	0.334	Note 6
		y		0.273	0.323	0.373	
	Red	x	$\theta = \Phi = 0^\circ$	0.515	0.565	0.615	
		y		0.284	0.334	0.384	
	Green	x	$\theta = \Phi = 0^\circ$	0.286	0.336	0.386	
		y		0.520	0.570	0.620	
	Blue	x	$\theta = \Phi = 0^\circ$	0.094	0.144	0.194	
		y		0.062	0.112	0.162	
View angle	Ver.	θL		60	70		Note 5
		θR	$\Phi = 0^\circ$ (3 o'clock)	60	70		
	Hor.	θT	$\Phi = 90^\circ$ (12 o'clock)	40	50		
		θB	$\Phi = 270^\circ$ (6 o'clock)	60	70		

Note1: Ambient condition: 25 °C±2 °C, 60±10%RH, under 10 Lunx in the darkroom.

Note2: Measure device: BM-7, viewing cone=1°, IL=40mA

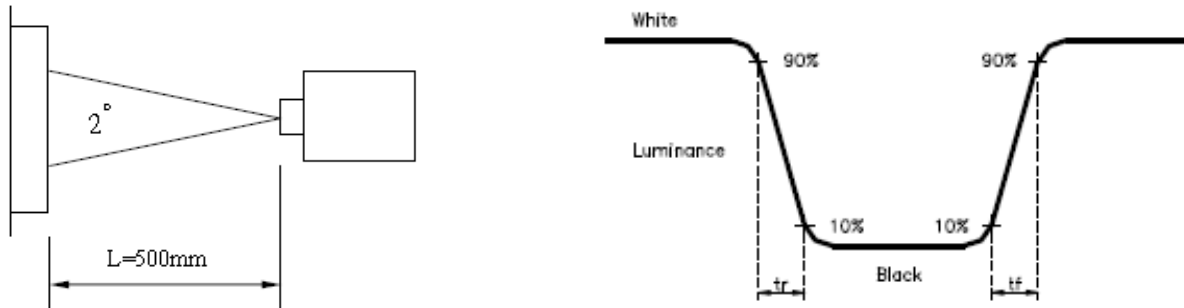

Note3: Definition of Contrast Ratio:

$$CR = \text{White Luminance (ON)} / \text{Black Luminance (OFF)}$$

Note4: Definition of response time: The response time is defined as the time interval between the 10% and 90% amplitudes.

Note5: Definition of viewing angle (θ , ψ):

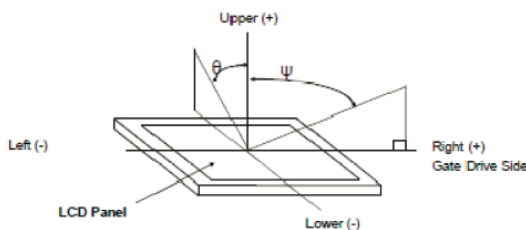

Definition of viewing angle

Note6: Light source: C light

8.PACKAGE.

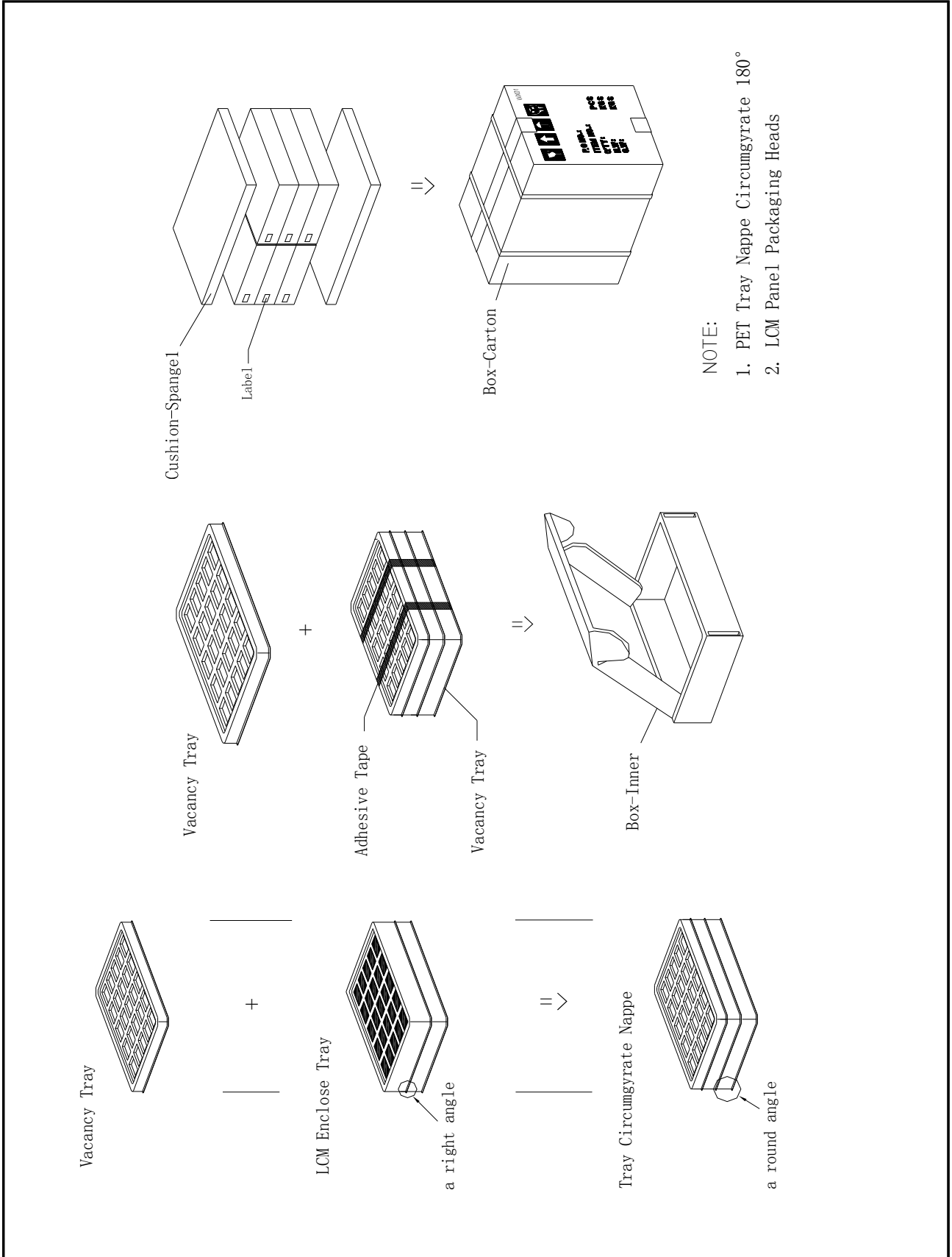

9. STANDARD SPECIFICATION FOR RELIABILITY:

Item	Condition		Time (hrs)	Assessment
High temp. Storage	85 °C		120	No abnormalities in functions and appearance
High temp.	80 °C		120	
Low temp. Storage	-30 °C		120	
Low temp. Operating	-35 °C		120	
Humidity	40 °C/ 90%RH		120	
Thermal Shock Temp. Cycle	-30 °C ← →70 °C (0.5hour ← → 0.5 hour)		10cycles	
ESD Testing	HBM:	±8KV		330Ω/150PF
	MM:	±200V		200PF/0Ω

Functions, performance, appearance, etc. shall be free from remarkable deterioration within 50,000 hours under ordinary operating and storage conditions room temperature (25 ± 10 °C), normal humidity ($45\pm 20\%$ RH), and in area not exposed to direct sun light. (Life time of backlight, please refer to Data about backlight.)

Testing Conditions and Inspection Criteria:

For the final test the testing sample must be stored at room temperature for 24 hours, after the tests listed in up Table, Standard specifications for Reliability have been executed in order to ensure stability.

Item	Test Model	In section Criteria
Current Consumption	Refer To Specification	The current consumption should conform to the product specification.
Contrast	Refer To Specification	After the tests have been executed, the contrast must be larger than half of its initial value prior to the tests.
Appearance	Visual inspection	Defect free.

10.SPECIFICATION OF QUALITY ASSURANCE:

10-1 Purpose

This standard for Quality Assurance should affirm the quality of LCD Module products to supply to purchaser by Future Focus.

10-2 Standard for Quality Test

a. Inspection:

Before delivering, the supplier should take the following tests, and affirm the quality of product.

b. Electro-Optical Characteristics:

According to the individual specification to test the product.

c. Test of Appearance Characteristics:

According to the individual specification to test the product.

d. Test of Reliability Characteristics:

According to the definition of reliability on the specification for testing products.

e. Delivery Test:

Before delivering, the supplier should take the delivery test.

(i) Test method: According to MIL-STD105E.General Inspection Level II take a single time.

(ii) The defects classify of AQL as following:

Major defect: AQL = 0.65

Minor defect: AQL = 2.5

Total defects: AQL = 2.5

10-3. Nonconforming Analysis & Deal With Manners

a. Nonconforming Analysis:

(i) Purchaser should supply the detail data of non- conforming sample and the non- conforming.

(ii) After accepting the detail data from purchaser, the analysis of nonconforming should be finished in two weeks.

(iii) If supplier can not finish analysis on time, must announce purchaser before two weeks.

b. Disposition of nonconforming:

(i) If find any product defect of supplier during assembly time, supplier must change the good product for every defect after recognition.

(ii) Both supplier and customer should analyze the reason and discuss the disposition of nonconforming when the reason of nonconforming is not sure.

10-4. Agreement items

Both sides should discuss together when the following problems happen.

a. There is any problem of standard of quality assurance, and both sides think that it must be modified.

b. There is any argument item which does not record in the standard of quality assurance.

c. Any other special problem.

10-5 Standard of The Product Appearance Test

a. Manner of appearance test: This specification should be applied for both light on and off situation.

(i) The test must be under 20W × 2 or 40W fluorescent light, and the distance of view must be at 30±5cm.

(ii) When test the model of transmissive product must add the reflective plate.

(iii) The test direction is base on about around 10° of vertical line (Left graph)

(iii) Temperature: 25±5 °C Humidity: 65±10%RH

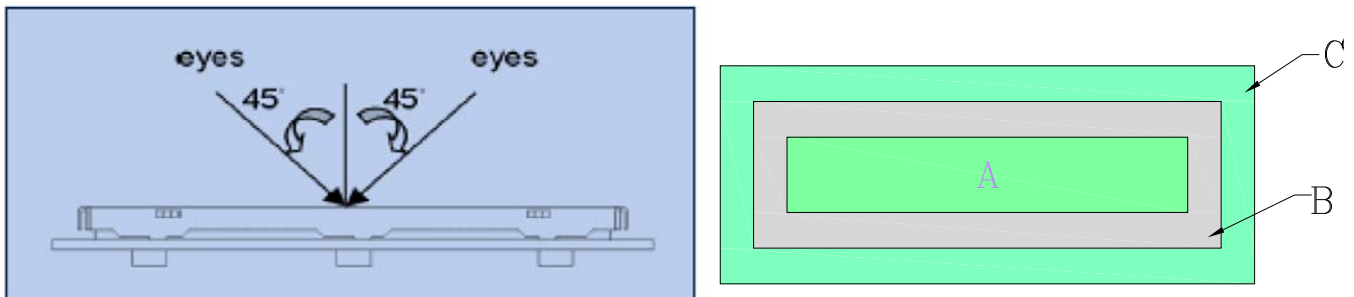

(iv) Definition of area (Right graph)

A. Area: Viewing area. B. Area: Out of viewing area. (Outside viewing area)

b. Basic principle:

(i) It will accord to the AQL when the standard can not be described.

(ii) The sample of the lowest acceptable quality level must be discussed by both supplier and customer when any dispute happened.

(iii) Must add new item on time when it is necessary.

c. Standard of inspection: (Unit: mm)

Allowable limits defined in follow Dot defect Table should be met for each white, black, R, G, B raster. The limits apply to the entire area. Missing white in 60% or more of typical (one color, R or G or B) pixel aperture is defined as a bright defect, less than 60% is acceptable. Black spot in 60% or more of typical pixel aperture is defined as a dark defect, less than 60% is acceptable.

Dot defect table:

Item		White dot defect	Black dot defect	Total
1	Defect counts	3	3	3
2	Combined defect Counts	No combined dot defect allowed. Two Single dot defect that within 5mm during each dot defect should be counted as combined dot defect.		

10-6 Inspection specification

AQL inspection standard

Sampling method: MIL-STD-105E, Level II, single sampling

Classify	Item		Note	AQL
Major	Display state	Short or open circuit	1	0.65
		Contrast defect (dim, ghost)		
		LC leakage		
		Flickering		
		No display		
	Non-display	Wrong viewing direction	2	
		Wrong Back-light	7	
		Flat cable or pin reverse	9	
Minor	Display state	Wrong or missing component	10	
		Background color deviation	2	
		Black spot and dust	3	
		Line defect	4	
		Scratch		
		Rainbow	5	
	Pin hole	6		
	Polarizer	Bubble and foreign material	3	
		Scratch	4	
	PCB,FPC	Scratch	4	
	Soldering	Poor connection	8	
Wire	Poor connection	9		
LCD	CHIP OUT	11		

Note on defect classification:

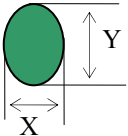
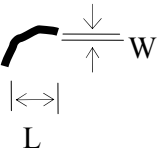
No.	Item	Criterion																	
1	<i>Short or open circuit</i>	Not allow																	
	<i>LC leakage</i>																		
	<i>Flickering</i>																		
	<i>No display</i>																		
	<i>Wrong viewing direction</i>																		
	<i>Wrong Back-light</i>																		
2	<i>Contrast defect</i>	Refer to approval sample																	
	<i>Background color deviation</i>																		
3	<p><i>Point defect, Black spot, dust (incl. Polarizer) ex.: dirt under polarizer, Pinhole of reflector, glass scratch, dirt under glass, scratch on polarizer</i></p> <p>$\phi = (X+Y)/2$</p>	 <table border="1" data-bbox="893 1041 1308 1276"> <thead> <tr> <th>Point Size</th> <th>Acceptable Qty.</th> </tr> </thead> <tbody> <tr> <td>$\phi \leq 0.20$</td> <td>Disregard</td> </tr> <tr> <td>$0.20 < \phi \leq 0.25$</td> <td>3</td> </tr> <tr> <td>$0.25 < \phi \leq 0.30$</td> <td>2</td> </tr> <tr> <td>$\phi > 0.30$</td> <td>0</td> </tr> </tbody> </table> <p>Unit: mm</p>	Point Size	Acceptable Qty.	$\phi \leq 0.20$	Disregard	$0.20 < \phi \leq 0.25$	3	$0.25 < \phi \leq 0.30$	2	$\phi > 0.30$	0							
Point Size	Acceptable Qty.																		
$\phi \leq 0.20$	Disregard																		
$0.20 < \phi \leq 0.25$	3																		
$0.25 < \phi \leq 0.30$	2																		
$\phi > 0.30$	0																		
4	<p><i>Line defect</i></p>	 <table border="1" data-bbox="869 1534 1396 1769"> <thead> <tr> <th>L</th> <th>Line W</th> <th>Acceptable Qty.</th> </tr> </thead> <tbody> <tr> <td>---</td> <td>$0.015 \geq W$</td> <td>Disregard</td> </tr> <tr> <td>$3.0 \geq L$</td> <td>$0.03 \geq W$</td> <td rowspan="2">2</td> </tr> <tr> <td>$2.0 \geq L$</td> <td>$0.05 \geq W$</td> </tr> <tr> <td>$1.0 \geq L$</td> <td>$0.1 > W$</td> <td>1</td> </tr> <tr> <td>---</td> <td>$0.05 < W$</td> <td>Applied as point defect</td> </tr> </tbody> </table> <p>Unit: mm</p>	L	Line W	Acceptable Qty.	---	$0.015 \geq W$	Disregard	$3.0 \geq L$	$0.03 \geq W$	2	$2.0 \geq L$	$0.05 \geq W$	$1.0 \geq L$	$0.1 > W$	1	---	$0.05 < W$	Applied as point defect
L	Line W	Acceptable Qty.																	
---	$0.015 \geq W$	Disregard																	
$3.0 \geq L$	$0.03 \geq W$	2																	
$2.0 \geq L$	$0.05 \geq W$																		
$1.0 \geq L$	$0.1 > W$	1																	
---	$0.05 < W$	Applied as point defect																	
5	<i>Rainbow</i>	<i>Not more than two color changes across the viewing area</i>																	

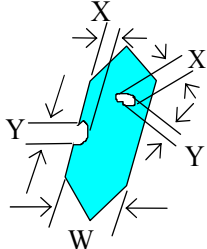
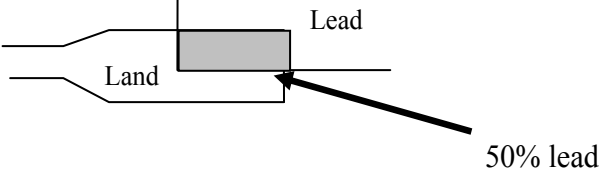
No.	Item	Criterion								
6	<p>Segment pattern $W = \text{Segment width}$ $\phi = (X+Y)/2$</p>	<p>(1) Pin hole $\phi < 0.10\text{mm}$ is acceptable.</p>  <table border="1" data-bbox="938 600 1377 788"> <thead> <tr> <th>Point Size</th> <th>Acceptable Qty</th> </tr> </thead> <tbody> <tr> <td>$\phi \leq 1/4W$</td> <td>Disregard</td> </tr> <tr> <td>$1/4W < \phi \leq 1/2W$</td> <td>1</td> </tr> <tr> <td>$\phi > 1/2W$</td> <td>0</td> </tr> </tbody> </table> <p style="text-align: right;">Unit: mm</p>	Point Size	Acceptable Qty	$\phi \leq 1/4W$	Disregard	$1/4W < \phi \leq 1/2W$	1	$\phi > 1/2W$	0
Point Size	Acceptable Qty									
$\phi \leq 1/4W$	Disregard									
$1/4W < \phi \leq 1/2W$	1									
$\phi > 1/2W$	0									
7	Back-light	<p>(1) <i>The color of backlight should correspond its specification.</i> (2) <i>Not allow flickering</i></p>								
8	Soldering	<p>(1) <i>Not allow heavy dirty and solder ball on PCB or FPC.</i> <i>(The size of dirty refer to point and dust defect)</i> (2) <i>Over 50% of lead should be soldered on Land.</i></p> 								
9	Wire	<p>(1) <i>Copper wire should not be rusted</i> (2) <i>Not allow crack on copper wire connection.</i> (3) <i>Not allow reversing the position of the flat cable.</i> (4) <i>Not allow exposed copper wire inside the flat cable.</i></p>								
10	PCB,FPC	<p>(1) <i>Not allow screw rust or damage.</i> (2) <i>Not allow missing or wrong putting of component.</i></p>								

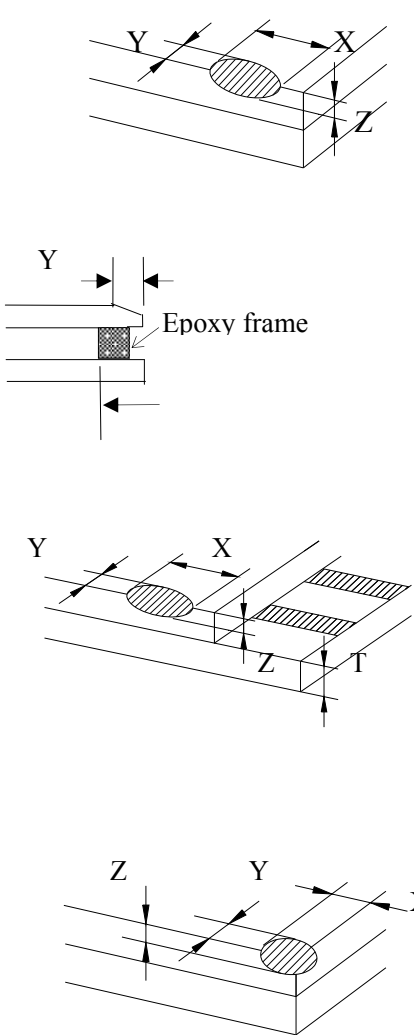
11	LCD	<p>2.1.1 chip on the surface</p>  <p style="text-align: center;">Note: A:LCD Length</p> <table border="1" data-bbox="734 1612 1276 1881"> <thead> <tr> <th>X</th> <th>Y</th> <th>Z</th> </tr> </thead> <tbody> <tr> <td>$>1/8A$</td> <td>$\leq 0.3\text{mm}$</td> <td>$\leq 1/2T$</td> </tr> <tr> <td rowspan="2">$\leq 1/8A$</td> <td>Not enter into epoxy frame</td> <td>$\leq T$</td> </tr> <tr> <td>Not enter into the inner edge of epoxy</td> <td>$\leq 1/2T$</td> </tr> </tbody> </table>	X	Y	Z	$>1/8A$	$\leq 0.3\text{mm}$	$\leq 1/2T$	$\leq 1/8A$	Not enter into epoxy frame	$\leq T$	Not enter into the inner edge of epoxy	$\leq 1/2T$
X	Y	Z											
$>1/8A$	$\leq 0.3\text{mm}$	$\leq 1/2T$											
$\leq 1/8A$	Not enter into epoxy frame	$\leq T$											
	Not enter into the inner edge of epoxy	$\leq 1/2T$											

11

LCD

2.1.2 Chip on the terminal

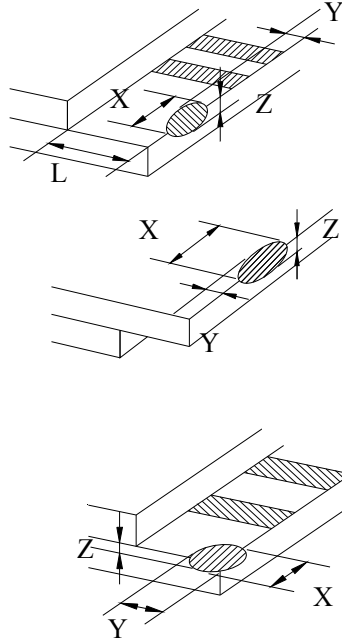

X	Y	Z
$>1/8A$	$\leq 0.3\text{mm}$	$\leq 1/2T$
$\leq 1/8A$	$\leq 1/2L$	$\leq T$
$\leq 1/8A \& \leq 1\text{mm}$	$\leq L$	$\leq T$
$\leq 1/8A \& \leq 2\text{mm}$	$\leq L$	$\leq 1/2T$

Note: A: LCD Length.

the distance between crack and contact pad must be greater than the width of 1st contact pad.

2.1.3 Chip out on between side

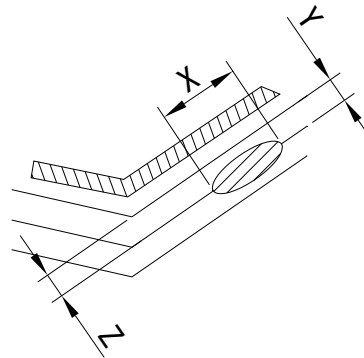

11

LCD

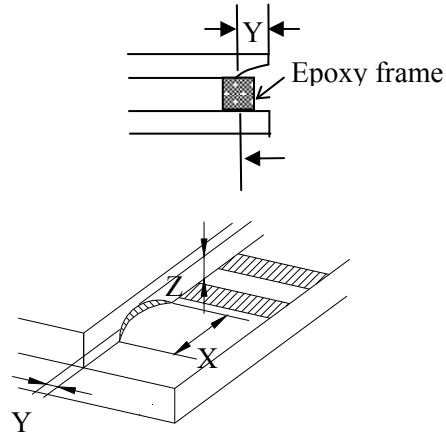

X	Y	Z
$\leq 1/8A$	Not enter into epoxy frame	$Z \leq 2T$
	Not enter into 1/2 epoxy frame	$Z \leq 1/2T$

Note: A : LCD Length

2.1.4 including corner chip and side chip

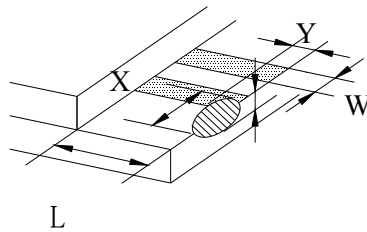

Note: A:LCD Length

X	Y	Z
$>1/8A$	$\leq 1/6L$	$\leq 1/2T$
$\leq 1/8A$	$\leq 1/3L$	
$\leq 1/4W$	$\leq 2/3L$	

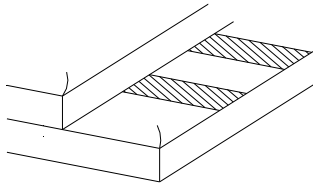
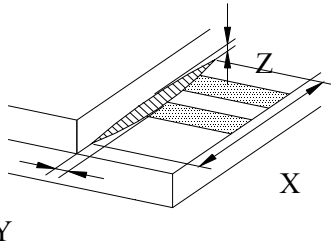
11	LCD	<p>2.2 Chip out</p>  <ol style="list-style-type: none"> 1) Chip out is that crackles extend to inner edge. 2) Crackles round epoxy frame will be rejected. 3) Chip out on the terminal will be rejected: $Z=T$ length $>1mm$ or $Z<T$ length $>2mm$ 4) The chip out at ITO will be rejected. 							
		<p>2.3 Poor cutting</p>  <table border="1" data-bbox="662 1122 1142 1368"> <thead> <tr> <th>X</th> <th>Y</th> <th>Z</th> </tr> </thead> <tbody> <tr> <td>$>1/8$ A</td> <td>≤ 0.3</td> <td>$\leq 1/2T$</td> </tr> <tr> <td>$\leq 1/8$ A</td> <td>According to drawing</td> <td>$1/2T \leq Z \leq T$</td> </tr> </tbody> </table> <p>Note : A: LCD Length.</p>	X	Y	Z	$>1/8$ A	≤ 0.3	$\leq 1/2T$	$\leq 1/8$ A
X	Y	Z							
$>1/8$ A	≤ 0.3	$\leq 1/2T$							
$\leq 1/8$ A	According to drawing	$1/2T \leq Z \leq T$							
12	SMT	<p>According to the <Acceptable of electronic assemblies> IPC-A-610C class 2 stander. Component missing or function defect are Major defect ,the others are Minor defect.</p>							
<p>Any one out of the specification will be rejected.</p>									

11. GENERAL PRECAUTIONS

(1) Mounting Method

The panel of the LCD Module consists of two thin glass plates with polarizers which easily get damaged since the Module is fixed by utilizing fitting holes in the printed circuit board. Extreme care should be taken when handling the LCD Modules.

(2) Caution of LCD handling & cleaning

When cleaning the display surface, use soft cloth with solvent (recommended below) and wipe lightly.

- Isopropyl alcohol*
- Ethyl alcohol*
- Trichlorotrifluoroethane*

Do not wipe the display surface with dry or hard materials that will damage the polarizer surface. Do not use the following solvent:

- Water*
- Ketone*
- Aromatics*

(3) Caution against static charge

The LCD Module use C-MOS LSI drivers, so we recommend that you connect any unused input terminal to VDD or VSS, do not input any signals before power is turned on. And ground your body, Work/assembly table. And assembly equipment to protect against static electricity.

(4) Packaging

Modules use LCD elements, and must be treated as such. Avoid intense shock and falls from a height.

- To prevent modules from degradation. Do not operate or store them exposed directly to sunshine or high temperature/humidity.*

(5) Caution for operation

- It is indispensable to drive LCD's within the specified voltage limit since the higher voltage than the limit shorten LCD life. An electrochemical reaction due to direct current causes LCD deterioration, Avoid the use of direct current drive.

- Response time will be extremely delayed at lower temperature than the operating temperature range and on the other hand at higher temperature LCD's show dark color in them.

However those phenomena do not mean malfunction or out of order with LCD's which will come back in the specified operating temperature range.

- If the display area is pushed hard during operation, some font will be abnormally displayed but*



深圳市宇华微科技有限公司

it resumes normal condition after turning off once.

- As light dew depositing on terminals is a cause for electro-chemical reaction resulting in terminal open circuit.

Usage under the relative condition of 40 °C, 50%RH or less is required.

(6) Storage

In the case of storing for a long period of time (for instance, for years) for the purpose or replacement use, the following ways are recommended.

- Storage in a polyethylene bag with sealed so as not to enter fresh air outside in it, And with no desiccant.

- Placing in a dark place where neither exposure to direct sunlight nor light is.

Keeping temperature in the specified storage temperature range.

- Storing with no touch on polarizer surface by the anything else. (It is recommended to store them as they have been contained in the inner container at the time of delivery)

(7) Safety

- It is recommendable to crash damaged or unnecessary LCD into pieces and wash off liquid crystal by using solvents such as acetone and ethanol which should be burned up later.

- When any liquid crystal leaked out of a damaged glass cell comes in contact with your hands, please wash it off well with soap and water.

Limited Warranty

Future-Focus LCD Modules are not consumer products, but may be incorporated by Future-Focus' customers into consumer products or components thereof, Future-Focus does not warrant that its components are fit for any such particular purpose.

- 1. The liability of Future-Focus is limited to repair or replacement on the terms set forth below. Future-Focus will not be responsible for any subsequent or consequential events or injury or damage to any personnel or user including third party personnel and/or user. Unless otherwise agreed in writing between Future-Focus and the customer, Future-Focus will only replace or repair any of its LCM which is found defective electrically or visually when inspected in accordance with Future-Focus.*
- 2. No warranty can be granted if any of the precautions state in handling liquid crystal display above has been disregarded. Broken glass, scratches on polarizer mechanical damages as well as defects that are caused accelerated environment tests are excluded from warranty.*
- 3. In returning the LCM, they must be properly packaged; there should be detailed description of the failures or defect.*

Future-Focus Limited reserves the right to change this specification.

- END -