

SPECIFICATION FOR LCM Module

MODULE No:	YH055FHFID018
CUSTOMER:	

STARTEK	INITIAL	DATE
PREPARED BY		
CHECKED BY		
APPROVED BY		

CUSTOMER	INITIAL	DATE
APPROVED BY		

Contents

1.	Block Diagram.....	5
2.	Outline dimension.....	6
3.	Input terminal Pin Assignment.....	7
3.1	TFT.....	7
4.	LCD Optical Characteristics.....	9
4.1	Optical specification.....	9
5.	TFT Electrical Characteristics.....	12
5.1	Absolute Maximum Rating (Ta=25 VSS=0V).....	12
5.2	DC Electrical Characteristics.....	12
5.3	LED Backlight Characteristics.....	13
6.	Timings for DSI Video mode.....	15
6.1	Vertical Timings.....	15
6.2	Horizontal Timings.....	16
6.3	Reset input timing.....	16
7.	LCD Module Out-Going Quality Level.....	20
7.1	VISUAL & FUNCTION INSPECTION STANDARD.....	20
7.1.1	Inspection conditions.....	20
7.1.2	Definition.....	20
7.1.3	Sampling Plan.....	21
7.1.4	Criteria (Visual).....	22
8.	Reliability Test Result.....	26
9.	Cautions and Handling Precautions.....	27
9.1	Handling and Operating the Module.....	27
9.2	Storage and Transportation.....	27
10.	Packing.....	28

*** Description**

This is a color active matrix LTPS LCD using Low Temperature Poly-silicon TFT's (Thin Film Transistors) as an active switching devices. This module is composed of a Transmissive type LTPS-LCD Panel, driver circuit, back-light unit. The resolution of a 5.46 " LTPS-LCD contains 1080X1920 pixels, and can display up to 16.7M colors.

*** Features**

General Information Items	Specification	Unit	Note
	Main Panel		
Display area(AA)	68.04(H)*120.96(V) (5.5inch)	mm	
Driver element	LTPS TFT active matrix	-	
Display colors	16.7M	colors	
Number of pixels	1080(RGB)*1920	dots	
Pixel arrangement	RGB vertical stripe	-	
Pixel pitch	0.021(H)*0.063(V)	mm	
Viewing angle	ALL	o'clock	
Controller IC	HX8399-A	-	
Display mode	Transmissive /Normally Black	-	
LCM Interface	4-Lane MIPI	-	
Operating temperature	-20~+70	°C	-
Storage temperature	-30~+80	°C	-

*** Mechanical Information**

Item		Min.	Typ.	Max.	Unit	Note
Module size	Horizontal(H)		71.04		mm	-
	Vertical(V)		129.67		mm	-
	Depth(D)		1.45		mm	-
Weight			30		g	-

1. Block Diagram

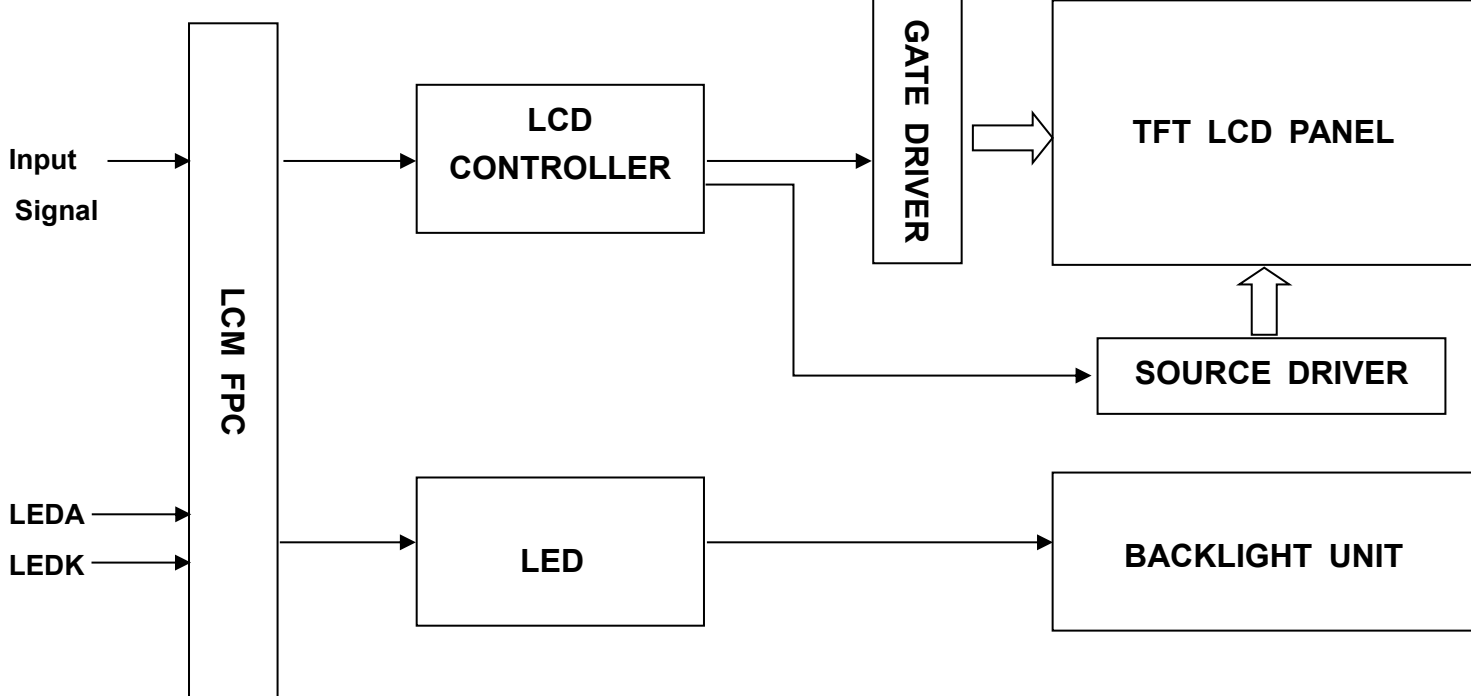

2. Outline dimension

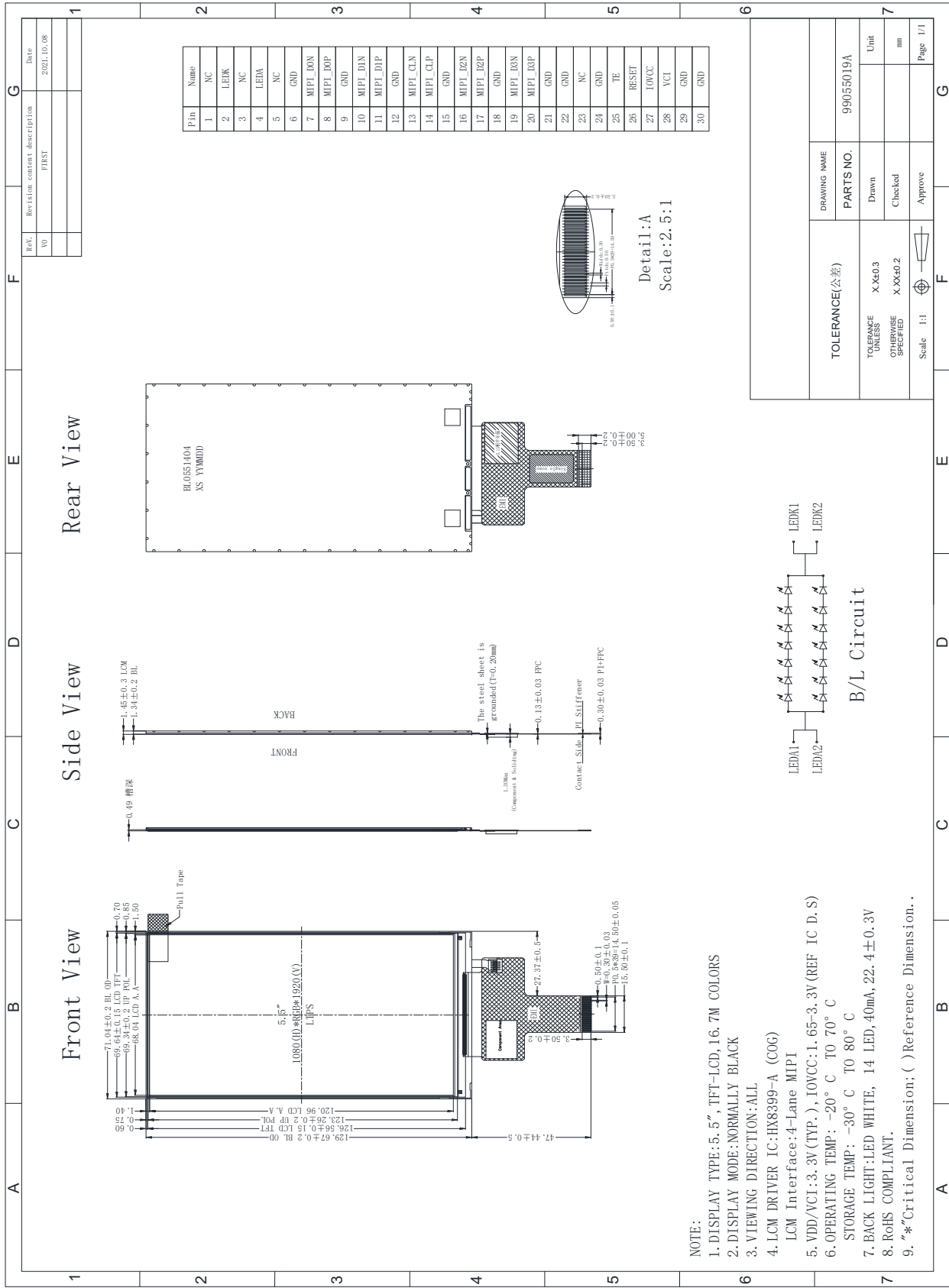

3. Input terminal Pin Assignment

3.1 TFT

NO.	SYMBOL	DISCRIPTION	I/O
1	NC	--	--
2	LEDK	Cathode pin of backlight.	P
3	NC	--	--
4	LEDA	Anode pin of backlight.	P
5	NC	--	--
6	GND	Ground	P
7	MIPI_D0N	MIPI DSI differential data pair (Data lane 0)	I/O
8	MIPI_D0P		
9	GND	Ground	P
10	MIPI_D1N	MIPI DSI differential data pair (Data lane 1)	I
11	MIPI_D1P		
12	GND	Ground	P
13	MIPI_CLN	MIPI DSI differential data pair .	I
14	MIPI_CLP		
15	GND	Ground.	P
16	MIPI_D2N	MIPI DSI differential data pair (Data lane 2)	I
17	MIPI_D2P		
18	GND	Ground	P
19	MIPI_D3N	MIPI DSI differential data pair (Data lane 3)	I
20	MIPI_D3P		
21	GND	Ground.	P
22	GND	Ground.	P
23	NC	--	--
24	GND	Ground.	P
25	TE	Tearing effect output pin. L th pin open when not in use.	O

26	RESET	The external reset input Initializes the chip with a low input .Be sure to execute a power-on reset after supplying power. Fix to IOVCC level when not in use.	I
27	IOVCC	Power supply for I/O pad	I
28	VCI	Power supply for analog circuits.	I
29	GND	Ground.	P
30	GND	Ground.	P

4. LCD Optical Characteristics

4.1 Optical specification

Item	Symbol	Condition	Min.	Typ.	Max.	Unit.	Note	
Contrast Ratio	CR	$\Theta=0$	800	1000	--		(1)(2)	
Response time	Rising	T_{R+T_F}	Normal viewing angle	--	35	45	msec	(1)(3)
	Falling							
Color gamut	S(%)		52	57.54		%	(1)	
Color Filter Chromaticity	White	W_X	-0.04	0.297	+0.04		(1)(4)	
		W_Y		0.332				
	Red	R_X		0.632				
		R_Y		0.350				
	Green	G_X		0.301				
		G_Y		0.588				
	Blue	B_X		0.148				
		B_Y		0.064				
Viewing angle	Hor.	Θ_L	CR>10	70	80	--	(1)(4)	
		Θ_R		70	80	--		
	Ver.	Θ_U		70	80	--		
		Θ_D		70	80	--		
Option View Direction	ALL						(5)	

*The data comes from the LCD specification.

Measuring Condition

Measuring surrounding : dark room

Ambient temperature : 25±2°C

15min. warm-up time.

Measuring Equipment

FPM520 of Westar Display technologies, INC., which utilized SR-3 for Chromaticity and BM-5A for other optical characteristics.

Note (1): Definition of Viewing Angle :

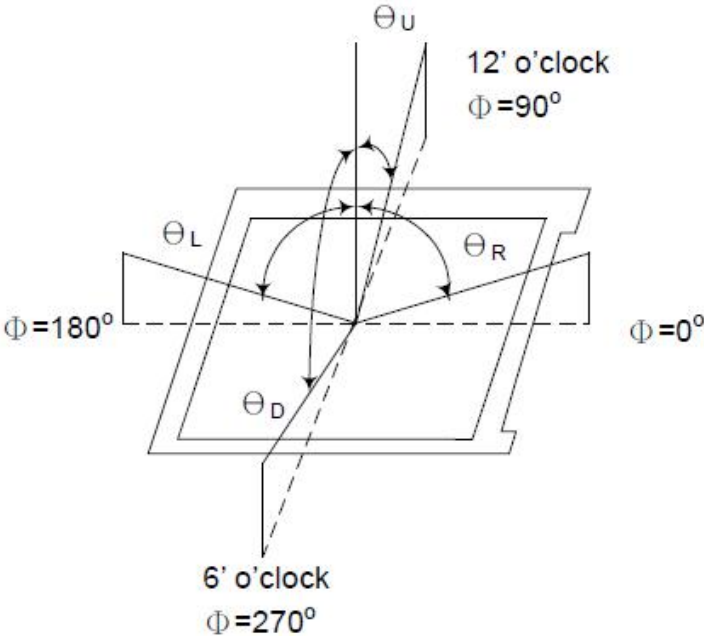

Note (2): Definition of Contrast Ratio(CR) :measured at the center point of panel

$$CR = \frac{\text{Luminance with all pixels white}}{\text{Luminance with all pixels black}}$$

Note (3): Response Time

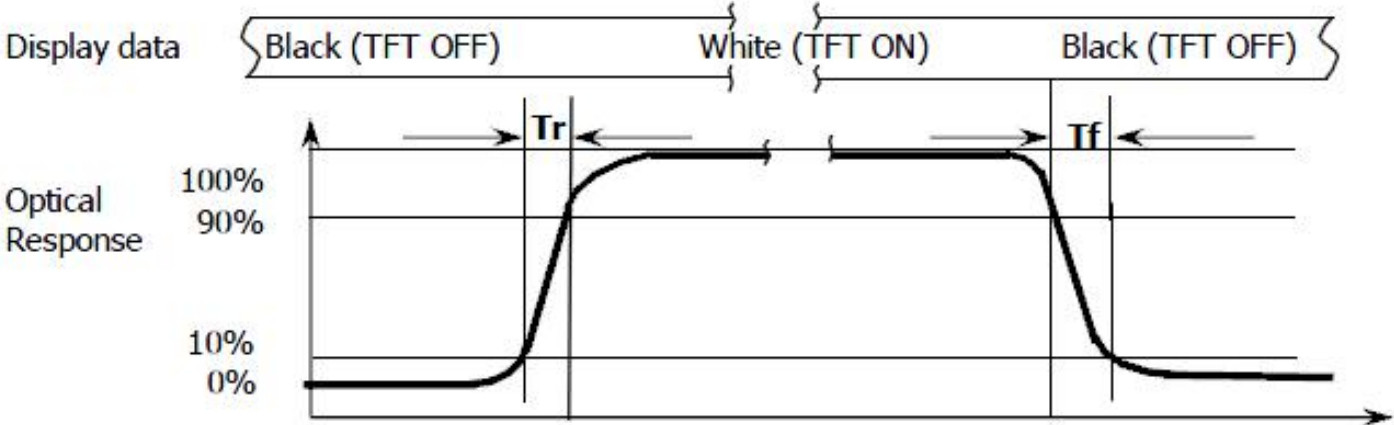

Note (4): Definition of optical measurement setup

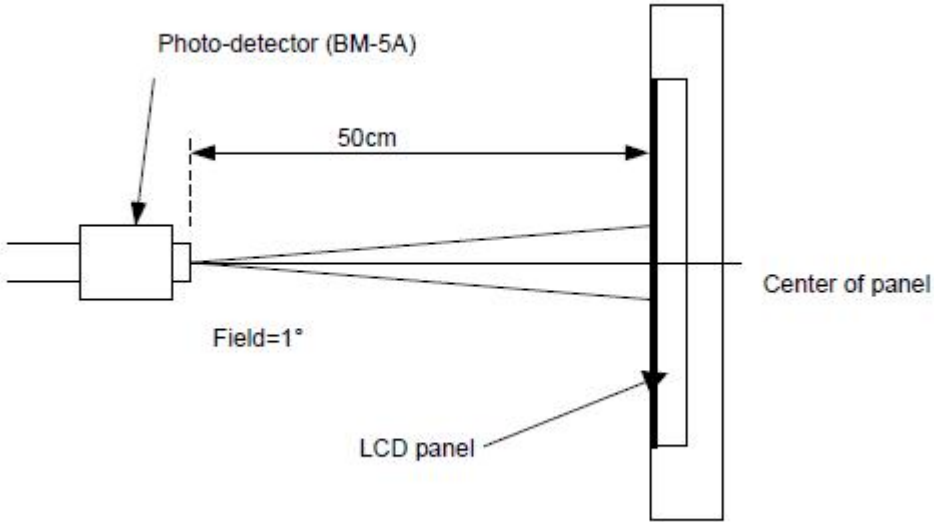

5. TFT Electrical Characteristics

5.1 Absolute Maximum Rating (Ta=25 VSS=0V)

Characteristics	Symbol	Min.	Max.	Unit
Digital Supply Voltage	VCI	-0.3	5.5	V
Supply Voltage (Logic)	IOVCC	-0.3	3.6	V
Operating temperature	T _{OP}	-20	+70	°C
Storage temperature	T _{ST}	-30	+80	°C

NOTE: If the absolute maximum rating of even is one of the above parameters is exceeded even momentarily, the quality of the product may be degraded. Absolute maximum ratings, therefore, specify the values exceeding which the product may be physically damaged. Be sure to use the product within the range of the absolute maximum ratings.

5.2 DC Electrical Characteristics

Characteristics	Symbol	Min.	Typ.	Max.	Unit	Note
Digital Supply Voltage	VCI	2.5	2.8	3.3	V	--
Supply Voltage (Logic)	IOVCC	1.65	1.8	3.3	V	--
Normal mode Current consumption	I _{VCI}	--	35	70	mA	--
	I _{IOVCC}	--	15	--		
Level input voltage	V _{IH}	0.7I _{OVCC}	--	I _{OVCC}	V	--
	V _{IL}	GND	--	0.3 I _{OVCC}	V	--
Level output voltage	V _{OH}	0.8I _{OVCC}	--	I _{OVCC}	V	--
	V _{OL}	GND	--	0.2I _{OVCC}	V	--

5.3 LED Backlight Characteristics

The back-light system is edge-lighting type with 14 chips White LED

Item	Symbol	Min.	Typ.	Max.	Unit	Note
Forward Current	I_F	30	40	--	mA	--
Forward Voltage	V_F	--	22.4	--	V	--
LCM Luminance	L_v	350	400	--	cd/m2	Note3
LED life time	Hr	50000			Hour	Note1,2
Uniformity	AVg	80	--	--	%	Note3

Note (1) LED life time (Hr) can be defined as the time in which it continues to operate under the condition: $T_a=25\pm3\text{ }^\circ\text{C}$, typical IL value indicated in the above table until the brightness becomes less than 50%.

Note (2) The "LED life time" is defined as the module brightness decrease to 50% original brightness at $T_a=25^\circ\text{C}$ and $I_L=40\text{mA}$. The LED lifetime could be decreased if operating I_L is larger than 40mA. The constant current driving method is suggested.

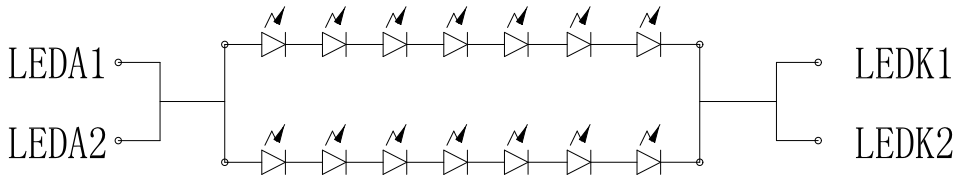

B1 CIRCUIT DIAGRAM

NOTE 3: Luminance Uniformity of these 9 points is defined as below:

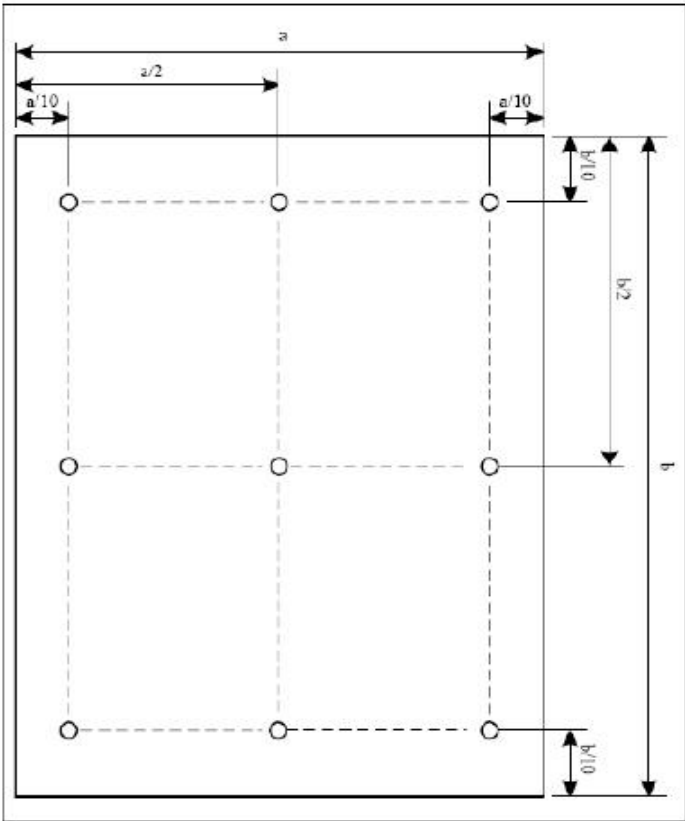

$$\text{Uniformity} = \frac{\text{minimum luminance in 9 points (1-9)}}{\text{maximum luminance in 9 points (1-9)}}$$

$$\text{Luminance} = \frac{\text{Total Luminance of 9 points}}{9}$$

6.2 Horizontal Timings

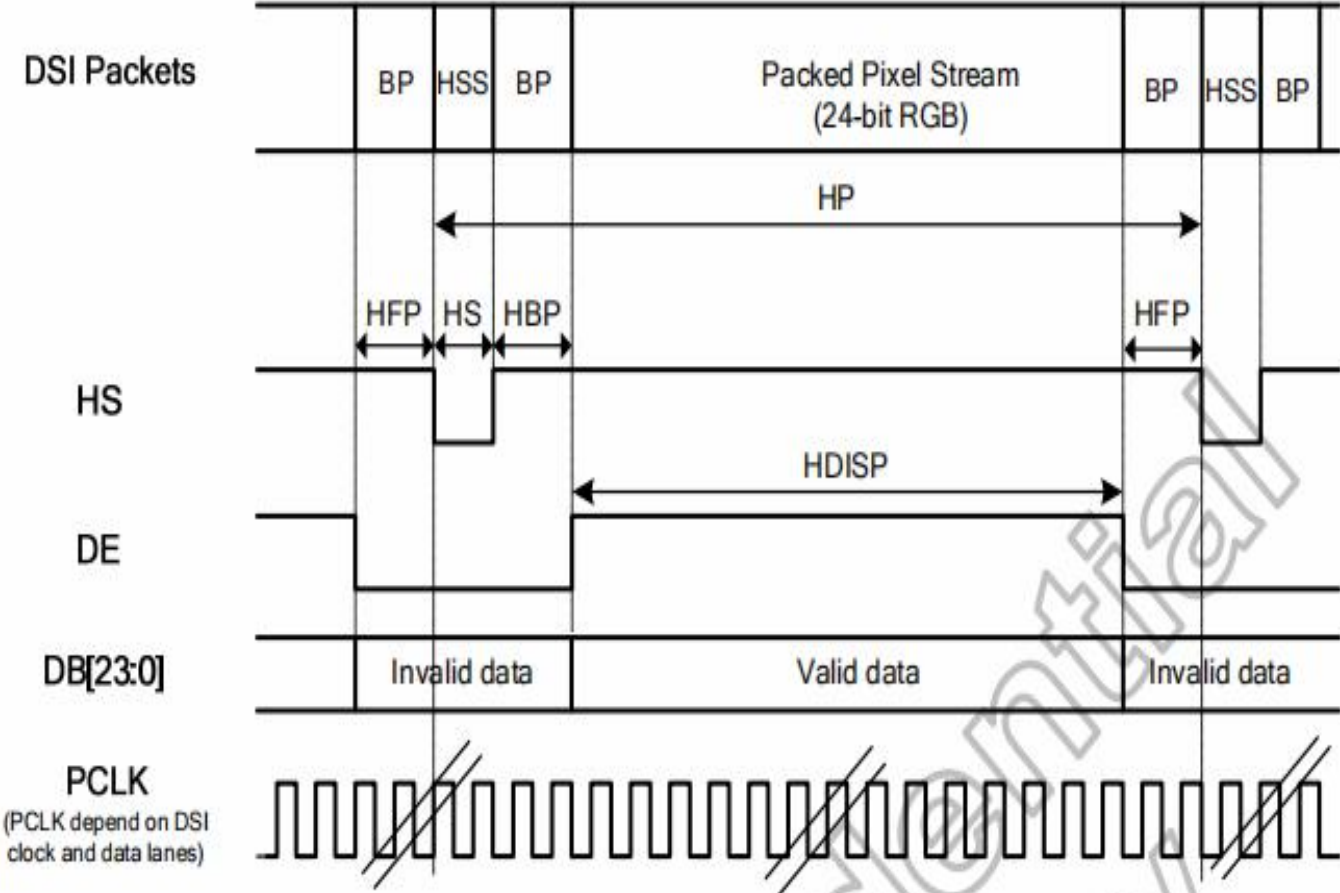

Figure 8.9: Horizontal Timing for DSI Video mode I/F

Please refer to the following table for the setting limitation of RGB interface signals.

Parameter	Symbol	Min.	Typ.	Max.	Unit
CLK frequency	FCLK	--	(130)	--	MHz
Horizontal valid data	thd	--	1080	---	CLK
Hsync pulse Width	thpw	4	8	--	CLK
Hsync back porch	thbp	7	20	--	CLK
Hsync front porch	thfp	2	10	--	CLK
Vertical valid data	tvd	--	1920	--	H
Vsync pulse width	tpw	1	8	--	H
Vsync back porch	tvbp	2	20	--	H
Vsync front porch	tvfp	6	10	--	H
Frame rate	FR	--	60	--	Hz

Note:

1. Typical value are related to the setting frame rate is 60Hz..s

6.3 Reset input timing

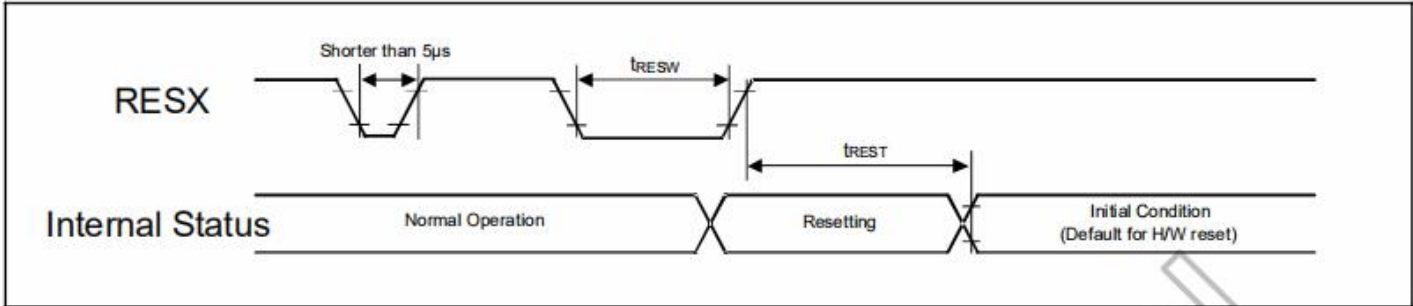

Figure 8.10: Reset input timing

Symbol	Parameter	Related pins	Min.	Typ.	Max.	Note	Unit
t_{RESW}	Reset low pulse width ⁽¹⁾	RESX	10	-	-	-	μs
t_{REST}	Reset complete time ⁽²⁾	-	-	-	5	HX8399-A reset execute period when reset is applied during Sleep In mode	ms
		-	-	-	120	HX8399-A reset execute period when reset is applied during Sleep Out mode	ms

Note: (1) Spike due to an electrostatic discharge on RESX line does not cause irregular system reset according to the table below.

RESX Pulse	Action
Shorter than 5 μs	Reset Rejected
Longer than 10 μs	Reset
Between 5 μs and 10 μs	Reset Start

- (2) During the resetting period, the display will be blanked (The display is entering blanking sequence, which maximum time is 120 ms, when Reset Starts in Sleep Out –mode. The display remains the blank state in Sleep In –mode) and then returns to Default condition for H/W reset.
- (3) During Reset Complete Time, OTP will be latched to internal register during this period. This loading is done every time when there is H/W reset complete time (t_{REST}) within 5ms after a rising edge of RESX.
- (4) Spike Rejection also applies during a valid reset pulse as shown below:

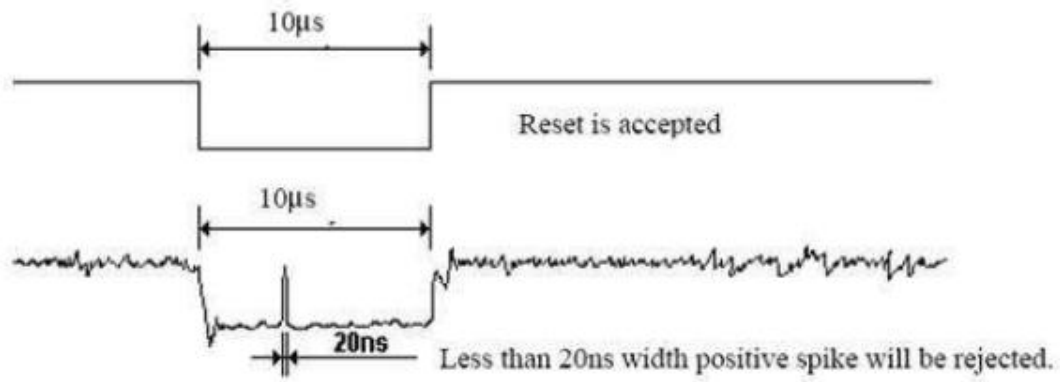

- (5) When Reset is applied during Sleep In Mode.
- (6) When Reset is applied during Sleep Out Mode.
- (7) It is necessary to wait 5msec after releasing RESX before sending commands. Also Sleep Out command cannot be sent for 120msec.

Table 8.16: Reset timing

7. LCD Module Out-Going Quality Level

7.1 VISUAL & FUNCTION INSPECTION STANDARD

7.1.1 Inspection conditions

Inspection performed under the following conditions is recommended.

- Temperature : $25 \pm 5^{\circ}\text{C}$
- Humidity : $65\% \pm 10\% \text{RH}$
- Viewing Angle : Normal viewing Angle.
- Illumination: Single fluorescent lamp (300 to 700Lux)
- Viewing distance: 30-50cm

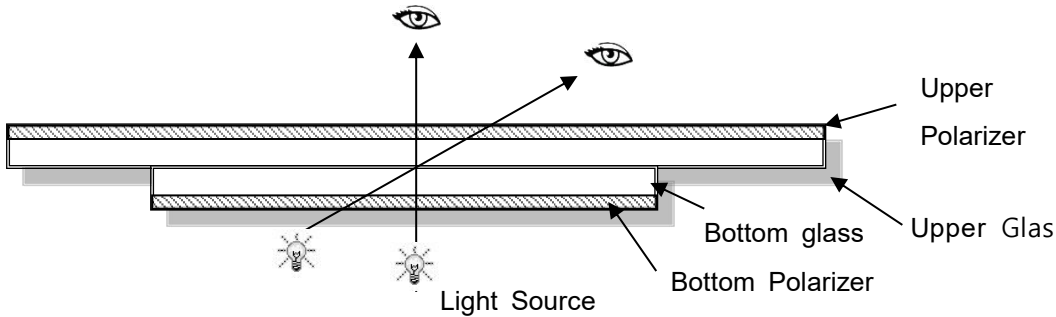

7.1.2 Definition

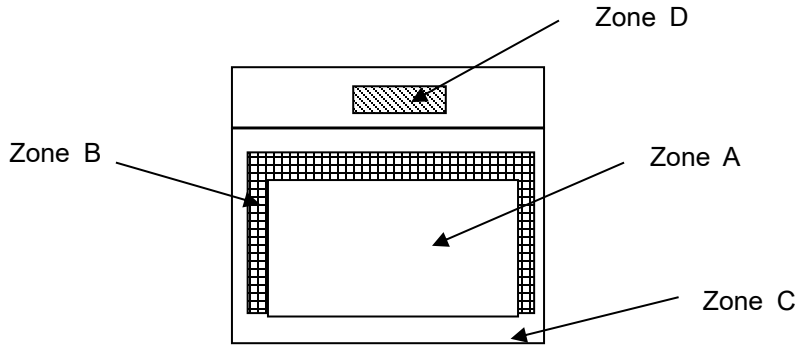

- Zone A : Effective Viewing Area(Character or Digit can be seen)
- Zone B : Viewing Area except Zone A
- Zone C Cover (Zone A+Zone B) which can not be seen after assembly by customer .)
- Zone D : IC Bonding Area

Note:

As a general rule ,visual defects in Zone C can be ignored when it doesn't effect product function or appearance after assembly by customer

7.1.3 Sampling Plan

According to GB/T 2828-2003 ; , normal inspection, Class II

AQL:

Major defect	Minor defect
0.65	1.5

LCD: Liquid Crystal Display , TP: Touch Panel , LCM: Liquid Crystal Module

No	Items to be inspected	Criteria	Classification of defects
1	Functional defects	1) No display, Open or miss line 2) Display abnormally, Short 3) Backlight no lighting, abnormal lighting.	Major
2	Missing	Missing component	
3	Outline dimension	Overall outline dimension beyond the drawing is not allowed	
4	Color tone	Color unevenness, refer to limited sample	Minor
5	Spot Line defect	Light dot, Dim spot, Polarizer Bubble ; Polarizer accidented spot.	
6	Soldering appearance	Good soldering , Peeling off is not allowed.	
7	LCD/Polarizer	Black/White spot/line, scratch, crack, etc.	



Note1: a) Light dot: Dots appear bright and unchanged in size in which LCD panel is displaying under black pattern.

b) Dim dot: Dots appear dark and unchanged in size in which LCD panel is displaying under pure red, green, blue picture.

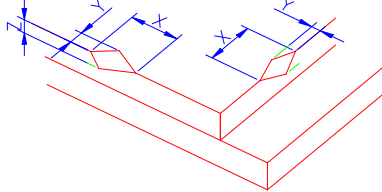
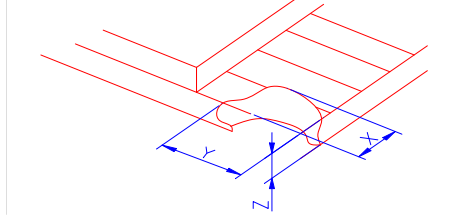
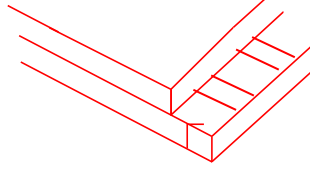
7.1.4 Criteria (Visual)

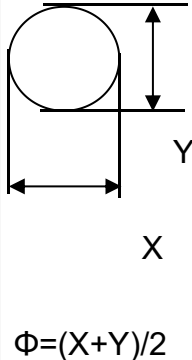
Number	Items	Criteria(mm)						
1.0 LCD Crack/Broken NOTE: X: Length Y: Width Z: Height L: Length of IT O, T: Height of LCD	(1) The edge of LCD broken	 <table border="1" data-bbox="758 672 1452 817"> <tr> <td>X</td> <td>Y</td> <td>Z</td> </tr> <tr> <td>≤3.0mm</td> <td><Inner border line of the seal</td> <td>≤T</td> </tr> </table>	X	Y	Z	≤3.0mm	<Inner border line of the seal	≤T
	X	Y	Z					
	≤3.0mm	<Inner border line of the seal	≤T					
(2) LCD corner broken	 <table border="1" data-bbox="837 1131 1372 1220"> <tr> <td>X</td> <td>Y</td> <td>Z</td> </tr> <tr> <td>≤3.0mm</td> <td>≤L</td> <td>≤T</td> </tr> </table>	X	Y	Z	≤3.0mm	≤L	≤T	
X	Y	Z						
≤3.0mm	≤L	≤T						
(3) LCD crack	 <p style="text-align: center;">Crack Not allowed</p>							

2.0	Spot defect	① light dot (black/white spot , pinhole, stain, etc.)																									
		<table border="1" style="width: 100%; border-collapse: collapse;"> <thead> <tr> <th rowspan="2" style="text-align: center;">Zone Size (mm)</th> <th colspan="3" style="text-align: center;">Acceptable Qty</th> </tr> <tr> <th style="text-align: center;">A</th> <th style="text-align: center;">B</th> <th style="text-align: center;">C</th> </tr> </thead> <tbody> <tr> <td style="text-align: center;">$\Phi \leq 0.15$</td> <td colspan="3" style="text-align: center;">Ignore</td> </tr> <tr> <td style="text-align: center;">$0.15 < \Phi \leq 0.25$</td> <td colspan="3" style="text-align: center;">3(distance ≥ 10mm)</td> </tr> <tr> <td style="text-align: center;">$0.25 < \Phi \leq 0.4$</td> <td colspan="3" style="text-align: center;">2(distance ≥ 10mm)</td> </tr> <tr> <td style="text-align: center;">$\Phi > 0.4$</td> <td colspan="3" style="text-align: center;">0</td> </tr> </tbody> </table>			Zone Size (mm)	Acceptable Qty			A	B	C	$\Phi \leq 0.15$	Ignore			$0.15 < \Phi \leq 0.25$	3(distance ≥ 10 mm)			$0.25 < \Phi \leq 0.4$	2(distance ≥ 10 mm)			$\Phi > 0.4$	0		
	Zone Size (mm)	Acceptable Qty																									
		A	B	C																							
$\Phi \leq 0.15$	Ignore																										
$0.15 < \Phi \leq 0.25$	3(distance ≥ 10 mm)																										
$0.25 < \Phi \leq 0.4$	2(distance ≥ 10 mm)																										
$\Phi > 0.4$	0																										
② Dim spot (light leakage, dent, dark spot, etc)																											
<table border="1" style="width: 100%; border-collapse: collapse;"> <thead> <tr> <th rowspan="2" style="text-align: center;">Zone Size (mm)</th> <th colspan="3" style="text-align: center;">Acceptable Qty</th> </tr> <tr> <th style="text-align: center;">A</th> <th style="text-align: center;">B</th> <th style="text-align: center;">C</th> </tr> </thead> <tbody> <tr> <td style="text-align: center;">$\Phi \leq 0.15$</td> <td colspan="3" style="text-align: center;">Ignore</td> </tr> <tr> <td style="text-align: center;">$0.15 < \Phi \leq 0.25$</td> <td colspan="3" style="text-align: center;">3(distance ≥ 10mm)</td> </tr> <tr> <td style="text-align: center;">$0.25 < \Phi \leq 0.4$</td> <td colspan="3" style="text-align: center;">2(distance ≥ 10mm)</td> </tr> <tr> <td style="text-align: center;">$\Phi > 0.4$</td> <td colspan="3" style="text-align: center;">0</td> </tr> </tbody> </table>			Zone Size (mm)	Acceptable Qty			A	B	C	$\Phi \leq 0.15$	Ignore			$0.15 < \Phi \leq 0.25$	3(distance ≥ 10 mm)			$0.25 < \Phi \leq 0.4$	2(distance ≥ 10 mm)			$\Phi > 0.4$	0				
Zone Size (mm)	Acceptable Qty																										
	A	B	C																								
$\Phi \leq 0.15$	Ignore																										
$0.15 < \Phi \leq 0.25$	3(distance ≥ 10 mm)																										
$0.25 < \Phi \leq 0.4$	2(distance ≥ 10 mm)																										
$\Phi > 0.4$	0																										
③ Polarizer accidented spot																											
<table border="1" style="width: 100%; border-collapse: collapse;"> <thead> <tr> <th rowspan="2" style="text-align: center;">Zone Size (mm)</th> <th colspan="3" style="text-align: center;">Acceptable Qty</th> </tr> <tr> <th style="text-align: center;">A</th> <th style="text-align: center;">B</th> <th style="text-align: center;">C</th> </tr> </thead> <tbody> <tr> <td style="text-align: center;">$\Phi \leq 0.2$</td> <td colspan="3" style="text-align: center;">Ignore</td> </tr> <tr> <td style="text-align: center;">$0.2 < \Phi \leq 0.5$</td> <td colspan="3" style="text-align: center;">2(distance ≥ 10mm)</td> </tr> <tr> <td style="text-align: center;">$\Phi > 0.5$</td> <td colspan="3" style="text-align: center;">0</td> </tr> </tbody> </table>			Zone Size (mm)	Acceptable Qty			A	B	C	$\Phi \leq 0.2$	Ignore			$0.2 < \Phi \leq 0.5$	2(distance ≥ 10 mm)			$\Phi > 0.5$	0								
Zone Size (mm)	Acceptable Qty																										
	A	B	C																								
$\Phi \leq 0.2$	Ignore																										
$0.2 < \Phi \leq 0.5$	2(distance ≥ 10 mm)																										
$\Phi > 0.5$	0																										
④ Polarizer Bubble																											
<table border="1" style="width: 100%; border-collapse: collapse;"> <thead> <tr> <th rowspan="2" style="text-align: center;">Zone Size (mm)</th> <th colspan="3" style="text-align: center;">Acceptable Qty</th> </tr> <tr> <th style="text-align: center;">A</th> <th style="text-align: center;">B</th> <th style="text-align: center;">C</th> </tr> </thead> <tbody> <tr> <td style="text-align: center;">$\Phi \leq 0.2$</td> <td colspan="3" style="text-align: center;">Ignore</td> </tr> <tr> <td style="text-align: center;">$0.2 < \Phi \leq 0.4$</td> <td colspan="3" style="text-align: center;">2(distance ≥ 10mm)</td> </tr> <tr> <td style="text-align: center;">$\Phi > 0.4$</td> <td colspan="3" style="text-align: center;">0</td> </tr> </tbody> </table>			Zone Size (mm)	Acceptable Qty			A	B	C	$\Phi \leq 0.2$	Ignore			$0.2 < \Phi \leq 0.4$	2(distance ≥ 10 mm)			$\Phi > 0.4$	0								
Zone Size (mm)	Acceptable Qty																										
	A	B	C																								
$\Phi \leq 0.2$	Ignore																										
$0.2 < \Phi \leq 0.4$	2(distance ≥ 10 mm)																										
$\Phi > 0.4$	0																										

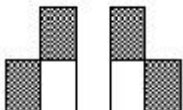
3.0	LCD Pixel defect	<p>Pixel bad points</p> <table border="1"> <thead> <tr> <th data-bbox="539 309 730 360">Item</th> <th data-bbox="730 309 1241 360">Zone A</th> <th data-bbox="1241 309 1497 360">Acceptable Qt</th> </tr> </thead> <tbody> <tr> <td data-bbox="539 360 730 521" rowspan="3">Bright dot</td> <td data-bbox="730 360 1241 416">Random</td> <td data-bbox="1241 360 1497 416">N≤2</td> </tr> <tr> <td data-bbox="730 416 1241 472">2 dots adjacent</td> <td data-bbox="1241 416 1497 472">N≤0</td> </tr> <tr> <td data-bbox="730 472 1241 521">3 dots adjacent</td> <td data-bbox="1241 472 1497 521">N≤0</td> </tr> <tr> <td data-bbox="539 521 730 689" rowspan="3">Dark dot</td> <td data-bbox="730 521 1241 577">Random</td> <td data-bbox="1241 521 1497 577">N≤3</td> </tr> <tr> <td data-bbox="730 577 1241 633">2 dots adjacent</td> <td data-bbox="1241 577 1497 633">N≤0</td> </tr> <tr> <td data-bbox="730 633 1241 689">3 dots adjacent</td> <td data-bbox="1241 633 1497 689">N≤0</td> </tr> <tr> <td data-bbox="539 689 730 1003">Distance</td> <td data-bbox="730 689 1241 1003"> 1. Minimum Distance Between Bright dots. 2. Minimum Distance Between dark dots 3. Minimum Distance Between dark and bright dot. </td> <td data-bbox="1241 689 1497 1003">5mm</td> </tr> <tr> <td colspan="2" data-bbox="539 1003 1241 1059">Total bright and dark dot</td> <td data-bbox="1241 1003 1497 1059">N≤4</td> </tr> </tbody> </table> <p>Note:</p> <p>A) Bright dot: Dots appear bright and unchanged in size in which LCD panel is displaying under black pattern.</p> <p>B) Dark dot: Dots appear dark and unchanged in size in which LCD panel is displaying under pure red, green, blue picture.</p> <p>C) 2 dot adjacent = 1 pair = 2 dots</p> <p>Picture:</p> <div style="display: flex; justify-content: space-around; align-items: flex-start;"> <div style="text-align: center;">  <p>2 dot adjacent</p> </div> <div style="text-align: center;">  <p>2 dot adjacent</p> </div> <div style="text-align: center;">  <p>2 dot adjacent (vertical)</p> </div> <div style="text-align: center;">  <p>2 dot adjacent (slant)</p> </div> </div>	Item	Zone A	Acceptable Qt	Bright dot	Random	N≤2	2 dots adjacent	N≤0	3 dots adjacent	N≤0	Dark dot	Random	N≤3	2 dots adjacent	N≤0	3 dots adjacent	N≤0	Distance	1. Minimum Distance Between Bright dots. 2. Minimum Distance Between dark dots 3. Minimum Distance Between dark and bright dot.	5mm	Total bright and dark dot		N≤4
Item	Zone A	Acceptable Qt																							
Bright dot	Random	N≤2																							
	2 dots adjacent	N≤0																							
	3 dots adjacent	N≤0																							
Dark dot	Random	N≤3																							
	2 dots adjacent	N≤0																							
	3 dots adjacent	N≤0																							
Distance	1. Minimum Distance Between Bright dots. 2. Minimum Distance Between dark dots 3. Minimum Distance Between dark and bright dot.	5mm																							
Total bright and dark dot		N≤4																							

4.0	Line defect (LCD /Polarizer backlight black/white line, scratch, stain)  W: width, L : length N : Count	<table border="1"> <thead> <tr> <th rowspan="2">Width(mm)</th> <th rowspan="2">Length(m)</th> <th colspan="3">Acceptable Qty</th> </tr> <tr> <th>A</th> <th>B</th> <th>C</th> </tr> </thead> <tbody> <tr> <td>$\Phi \leq 0.05$</td> <td>Ignore</td> <td colspan="2">Ignore</td> <td rowspan="3">Ignore</td> </tr> <tr> <td>$0.05 < W \leq 0.06$</td> <td>$L \leq 5.0$</td> <td colspan="2">$N \leq 3$</td> </tr> <tr> <td>$0.06 < W \leq 0.08$</td> <td>$L \leq 4.0$</td> <td colspan="2">$N \leq 2$</td> </tr> <tr> <td>$W > 0.08$</td> <td colspan="4">Define as spot defect</td> </tr> </tbody> </table>	Width(mm)	Length(m)	Acceptable Qty			A	B	C	$\Phi \leq 0.05$	Ignore	Ignore		Ignore	$0.05 < W \leq 0.06$	$L \leq 5.0$	$N \leq 3$		$0.06 < W \leq 0.08$	$L \leq 4.0$	$N \leq 2$		$W > 0.08$	Define as spot defect			
		Width(mm)			Length(m)	Acceptable Qty																						
			A	B		C																						
		$\Phi \leq 0.05$	Ignore	Ignore		Ignore																						
		$0.05 < W \leq 0.06$	$L \leq 5.0$	$N \leq 3$																								
$0.06 < W \leq 0.08$	$L \leq 4.0$	$N \leq 2$																										
$W > 0.08$	Define as spot defect																											
5.0	Electronic Components SMT.	Not allow missing parts, solderless connection, cold solder joint, mismatch, The positive and negative polarity opposite																										
6.0	Display color & Brightness.	1. Color: Measuring the color coordinates, The measurement standard according to the datasheet or samples. 2. Brightness: Measuring the brightness of White screen, The measurement standard according to the datasheet or Samples.																										
7.0	LCD Mura/Waving/ Hot spot	Not visible through 5% ND filter in 50% gray or judge by limit sample if necessary.																										

Criteria (functional items)

Number	Items	Criteria (mm)
1	No display	Not allowed
2	Missing segment	Not allowed
3	Short	Not allowed
4	Backlight no lighting	Not allowed
5	CTP no function	Not allowed

8. Reliability Test Result

High Temperature Operating	70°C,96H	Inspection after 2~4hours storage at room temperature, the sample shall be free from defects: 1.Air bubble in the LCD; 2.Non-display; 3.Missing segments/line; 4.Glass crack; 5.Current IDD is twice higher than initial value.
Low Temperature Operating	-20°C, 96HR	
High Temperature Storage	80°C, 96HR	
Low Temperature Storage	-30°C, 96HR	
High Temperature & High Humidity Storage	+60°C, 90% RH ,96 hours.	
Thermal Shock (Non-operation)	-30°C,30 min ↔ 80°C,30 min, Change time:5min 20CYC.	
ESD test	C=150pF, R=330,5points/panel Air:±8KV, 5times; Contact:±6KV, 5 times; (Environment: 15°C~35°C, 30%~60%).	
Vibration (Non-operation)	Frequency range:10~55Hz, Stroke:1.5mm Sweep:10Hz~55Hz~10Hz 2 hours for each direction of X.Y.Z. (6 hours for total) (Package condition).	
Box Drop Test	1 Corner 3 Edges 6 faces,80cm(MEDIUM BOX)	

Remark:

- 1.The test samples should be applied to only one test item.
- 2.Sample size for each test item is 5~10pcs.
- 3.For Damp Proof Test, Pure water(Resistance > 10MΩ) should be used.
- 4.In case of malfunction defect caused by ESD damage, if it would be recovered to normal state after resetting, it would be judged as a good part.
- 5.Failure Judgment Criterion: Basic Specification, Electrical Characteristic, Mechanical Characteristic, Optical Characteristic
6. The color fading mura of polarizing filter should not care.

9. Cautions and Handling Precautions

9.1 Handling and Operating the Module

- (1) When the module is assembled, it should be attached to the system firmly.
Do not warp or twist the module during assembly work.
- (2) Protect the module from physical shock or any force. In addition to damage, this may cause improper operation or damage to the module and back-light unit.
- (3) Note that polarizer is very fragile and could be easily damaged. Do not press or scratch the surface.
- (4) Do not allow drops of water or chemicals to remain on the display surface.
If you have the droplets for a long time, staining and discoloration may occur.
- (5) If the surface of the polarizer is dirty, clean it using some absorbent cotton or soft cloth.
- (6) The desirable cleaners are water, IPA (Isopropyl Alcohol) or Hexane.
Do not use ketene type materials (ex. Acetone), Ethyl alcohol, Toluene, Ethyl acid or Methyl chloride. It might permanent damage to the polarizer due to chemical reaction.
- (7) If the liquid crystal material leaks from the panel, it should be kept away from the eyes or mouth. In case of contact with hands, legs, or clothes, it must be washed away thoroughly with soap.
- (8) Protect the module from static; it may cause damage to the CMOS ICs.
- (9) Use finger-stalls with soft gloves in order to keep display clean during the incoming inspection and assembly process.
- (10) Do not disassemble the module.
- (11) Protection film for polarizer on the module shall be slowly peeled off just before use so that the electrostatic charge can be minimized.
- (12) Pins of I/F connector shall not be touched directly with bare hands.
- (13) Do not connect, disconnect the module in the "Power ON" condition.
- (14) Power supply should always be turned on/off by the item 6.1 Power On Sequence & 6.2 Power Off Sequence

9.2 Storage and Transportation.

- (1) Do not leave the panel in high temperature, and high humidity for a long time.
It is highly recommended to store the module with temperature from 0 to 35 °C and relative humidity of less than 70%
- (2) Do not store the TFT-LCD module in direct sunlight.
- (3) The module shall be stored in a dark place. When storing the modules for a long time, be sure to adopt effective measures for protecting the modules from strong ultraviolet radiation, sunlight, or fluorescent light.
- (4) It is recommended that the modules should be stored under a condition where no condensation is allowed. Formation of dewdrops may cause an abnormal operation or a failure of the module.
In particular, the greatest possible care should be taken to prevent any module from being operated where condensation has occurred inside.
- (5) This panel has its circuitry FPC on the bottom side and should be handled carefully in order not to be stressed.

Part. No		REV	V1.0	Page 27 of 28
----------	--	-----	------	---------------

10. Packing

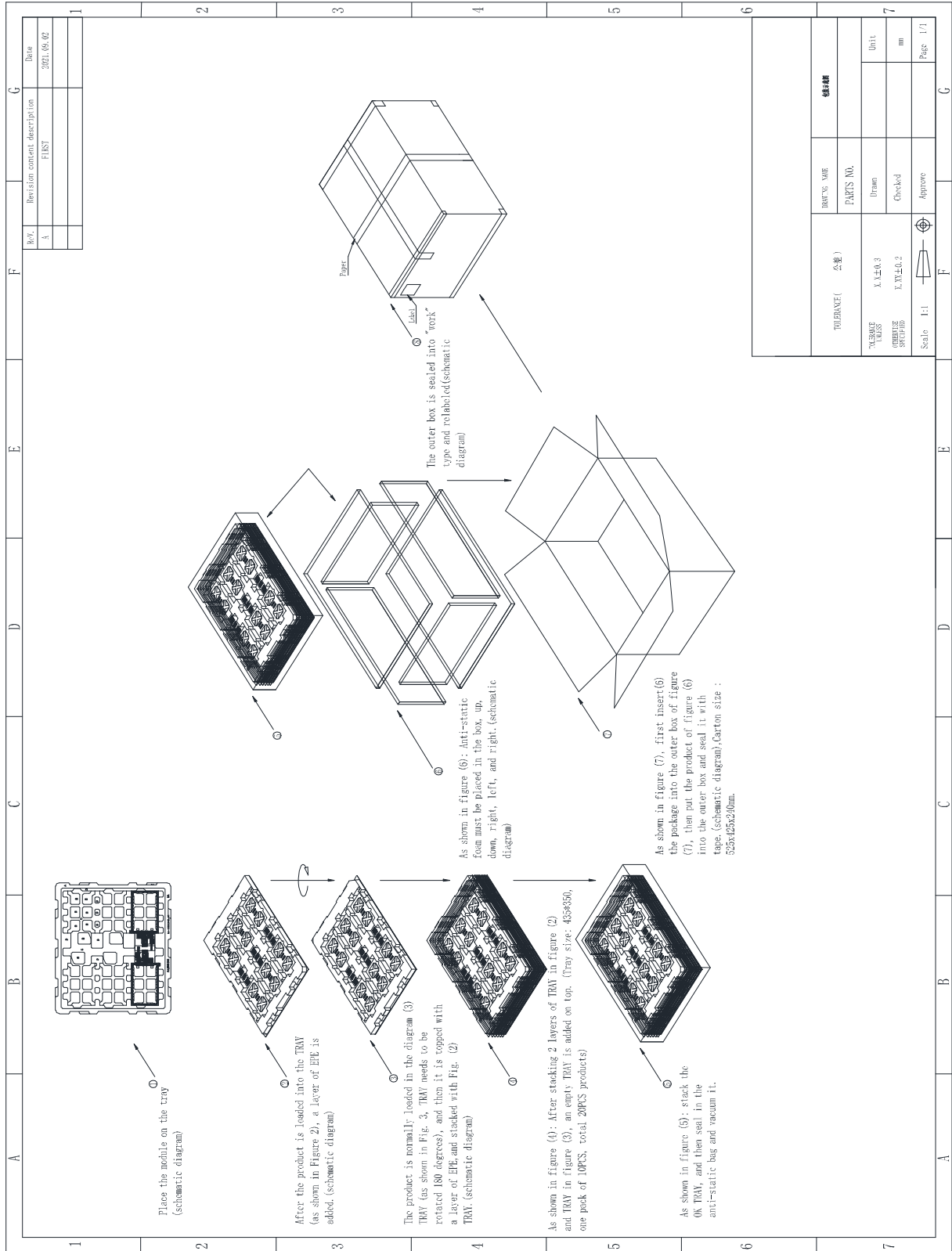

REV	Revision content description	Date
1	FIRST	2021.06.02

THIRNANCE(公差)	REWORK VALUE	REWORK VALUE
允差范围	PARTS NO.	零件号
允差范围	X.XX±0.3	Unit
允差范围	X.XX±0.2	Checked
Scale 1:1	Approve	Pages 1/1