

- Tentative Specification
- Preliminary Specification
- Approval Specification

MODELNAME:YH056TN52V.3

Version:R 01

Customer: Common	
APPROVED BY	SIGNATURE
Name / Title _____	_____
Note	

Please return 1 copy for your confirmation with your signature and comments.	

Approved By	Checked By	Prepared By

Revision History

Revision	Date	Originator	Detail	Remarks
1.0	2024-7-9		Initial Release	

Table of Contents

No.	Item	Page
1.	General Description	4
2.	Module Parameter	4
2.1.	Outline Drawing	5
3.	Absolute Maximum Ratings	6
4.	DC Characteristics	6
5.	Backlight Characteristics	7
5.1.	Backlight Characteristics	7
5.2.	Backlighting circuit	7
6.	Optical Characteristics	8
6.1.	Optical Characteristics	8
6.2.	Definition of Response Time	8
6.3.	Definition of Contrast Ratio	8
6.4.	Definition of Viewing Angles	8
6.5.	Definition of Color Appearance	8
6.6.	Definition of Surface Luminance, Uniformity and Transmittance	10
7.	Block Diagram and Power Supply	11
8.	Interface Pins Definition	10
9.	AC Characteristics	12
9.1.	AC Timing characteristics	15
9.2.	Display Timing characteristics	15
9.3.	Power ON/Off Sequence	15
10.	Quality Assurance	18
10.1.	Purpose	18
10.2.	Standard for Quality Test	18
10.3.	Nonconforming Analysis & Disposition	18
10.4.	Agreement Items	18
10.5.	Standard of the Product Visual Inspection	18
10.6.	Inspection Specification	19
10.7.	Classification of Defects	19
10.8.	Identification/marketing criteria	23
10.9.	Packing	23
11.	Reliability Specification	24
12.	Precautions and Warranty	26
12.1.	Safety	26
12.2.	Handling	26
12.3.	Storage	26
12.4.	Metal Pin (Apply to Products with Metal Pins)	26
12.5.	Operation	27
12.6.	Static Electricity	27
12.7.	Limited Warranty	27
13.	Packaging	28

1. General Description

The specification is a transmissive type color active matrix liquid crystal display (LCD) which uses amorphous thin film transistor (TFT) as switching devices. This product is composed of a TFT-LCD panel, driver Ics and a backlight unit.

2. Module Parameter

Features	Details	Unit
Display Size(Diagonal)	5.6"	
LCD type	TN TFT	
Display Mode	Transmissive / Normally White	
Resolution	640 RGB x 480	Pixels
View Direction	12 O'CLOCK	Best Image
Gray Scale Inversion Direction	6 O'CLOCK	
Module Outline	126.5(H) x 100(V) x 5.7(T) (Note1)	mm
Active Area	112.896(H) x84.672(V)	mm
Pixel Size	58.8*3 x 176.4	um
Pixel Arrangement	RGB	
Polarizer Surface Treatment	Anti-glare	
Driver IC	ILI6192A-01&ILI5481A	
Display Colors	16.7M	
Interface	24 Bits-RGB Interface	
With or Without Touch Panel	Without	-
Operating Temperature	-20~70	°C
Storage Temperature	-30~80	°C
Weight	100	g

Note 1: Exclusive hooks, posts, FFC/FPC tail etc.

3. Absolute Maximum Ratings

GND=0V, Ta=25°C

Item	Symbol	Min.	Max.	Unit
Supply Voltage	DVDD	-0.3	5.0	V
Storage temperature	T _{STG}	-30	+80	°C
Operating temperature	T _{OP}	-20	+70	°C

Note 1: If Ta below 50°C, the maximal humidity is 90%RH, if Ta over 50°C, absolute humidity should be less than 60%RH.

Note 2: The response time will be extremely slow when the operating temperature is around -10°C, and the back ground will become darker at high temperature operating.

4. DC Characteristics

Item	Symbol	Min.	Typ.	Max.	Unit
Supply Voltage	VGH	14.5	15	15.5	V
	VGL	-12.5	-12	-11.5	V
Common Electrode Driving Signal	VCOM	-0.77	-0.74	-0.71	V
Logic Low input voltage	V _{IL}	GND	-	0.3*DVDD	V
Logic High input voltage	V _{IH}	0.7*DVDD	-	DVDD	V

5. Backlight Characteristics

5.1. Backlight Characteristics

Item	Symbol	Condition	Min.	Typ.	Max.	Unit
Backlight Voltage	V _{LED}	Ta=25 °C, I _F =20mA/LED	-	9.3	-	V
Backlight Current	I _{LED}	Ta=25 °C, V _F =3.1V/LED	-	100	-	mA
Power dissipation	P _D		-	930	-	mW
Uniformity	Avg		75	80	-	%
LED working life(25°C)	-		20000	30000	-	Hrs
Drive method	Constant current					
LED Configuration	15 White LEDs(3 LEDs in one string and 5 groups in parallel)					

Note1: LED life time defined as follows: The final brightness is at 50% of original brightness.

The environmental conducted under ambient air flow, at Ta=25 ± 2 °C, 60%RH ± 5%, I_F=20mA/LED.

Note7: LED life time defined as follows: The final brightness is at 50% of original brightness.

The environmental conducted under ambient air flow, at Ta=25 ± 2 °C, 60%RH ± 5%, I_F=40mA/LED.

5.2. Backlighting circuit

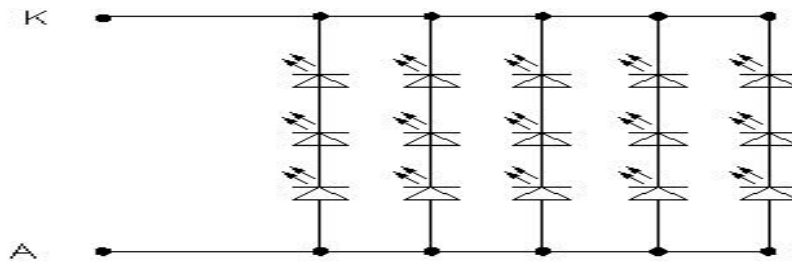

6. Optical Characteristics

6.1. Optical Characteristics

Ta=25°C, DVDD=3.3V

	Item	Symbol	Condition	Specification			Unit	
				Min.	Typ.	Max.		
Backlight On (Transmissive Mode)	Luminance on TFT ($I_f = 20\text{mA/LED}$)	Lv	Normally viewing angle $\theta_x = \phi_y = 0^\circ$	200	250	-	cd/m ²	
	Contrast ratio(See 6.3)	CR		600	1000	-		
	Response time (See 6.2)	T _R +T _F		-	25	50	ms	
	White	X _W		-				
		Y _W		-				
	Viewing Angle (See 6.4)	Horizontal	θ_{x+}	Center CR ≥ 10	60	70	-	Deg.
			θ_{x-}		60	70	-	
		Vertical	ϕ_{y+}		40	50	-	
			ϕ_{y-}		60	70	-	
	NTSC Ratio(Gamut)				-	51.2	-	%

6.2. Definition of Response Time

6.2.1. Normally Black Type (Negative)

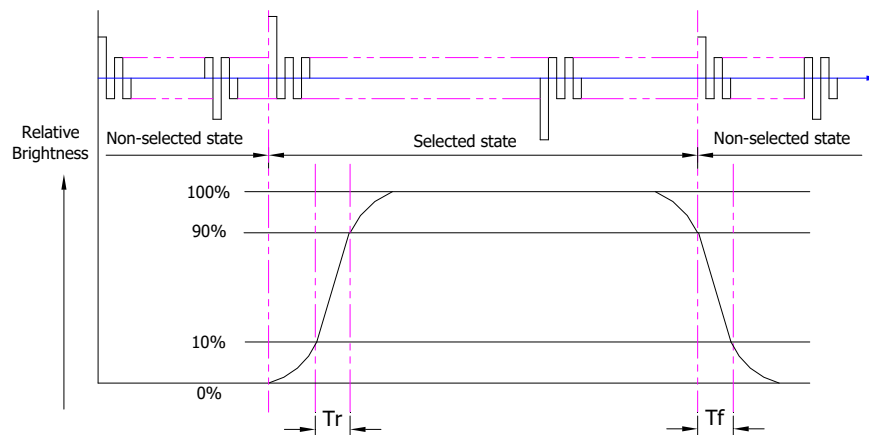

Tr is the time it takes to change from non-selected stage with relative luminance 10% to selected state with relative luminance 90%;

Tf is the time it takes to change from selected state with relative luminance 90% to non-selected state with relative luminance 10%

Note: Measuring machine: LCD-5100

6.2.2. Normally White Type (Positive)

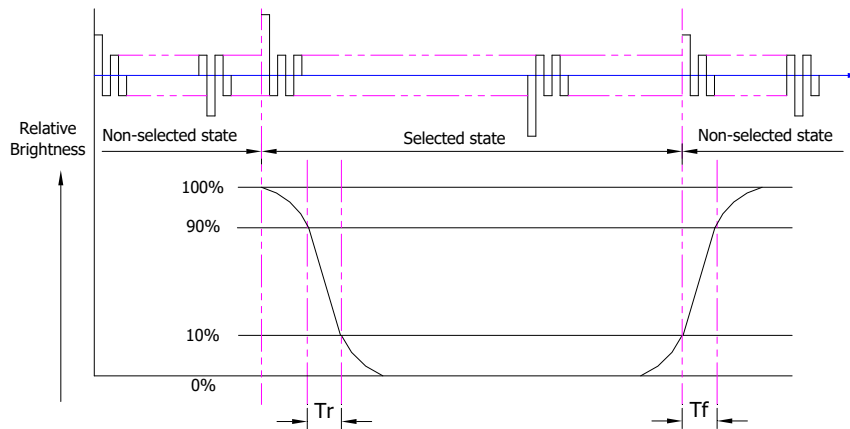

Tr is the time it takes to change from non-selected stage with relative luminance 90% to selected state with relative luminance 10%;

Tf is the time it takes to change from selected state with relative luminance 10% to non-selected state with relative luminance 90%;

Note: Measuring machine: LCD-5100 or EQUI

6.3. Definition of Contrast Ratio

Contrast is measured perpendicular to display surface in reflective and transmissive mode. The measurement condition is:

Measuring Equipment	Eldim or Equivalent
Measuring Point Diameter	3mm//1mm
Measuring Point Location	Active Area centre point
Test pattern	A: All Pixels white
	B: All Pixel black
Contrast setting	Maximum

Definitions: CR (Contrast) = Luminance of White Pixel / Luminance of Black Pixel

6.4. Definition of Viewing Angles

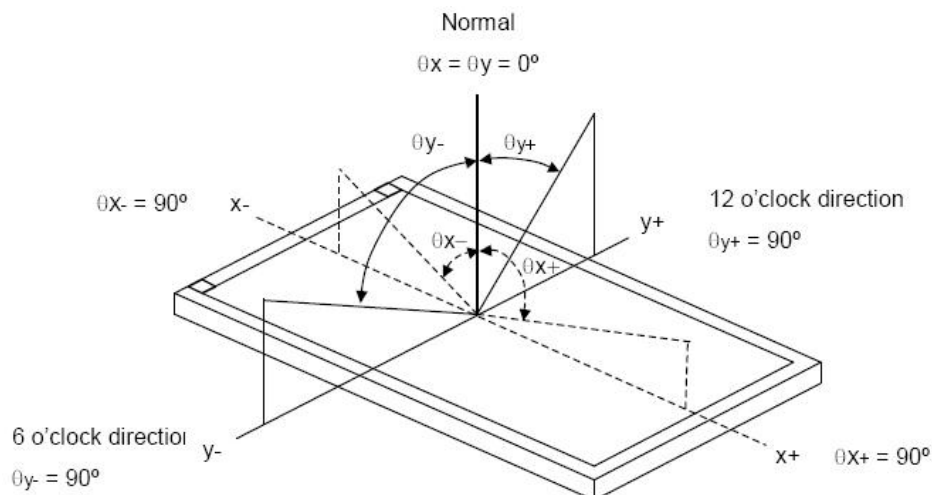

Measuring machine: LCD-5100 or EQUI

6.5. Definition of Color Appearance

R,G,B and W are defined by (x, y) on the IE chromaticity diagram

NTSC=area of RGB triangle/area of NTSC triangleX100%

Measuring picture: Red, Green, Blue and White (Measuring machine: BM-7)

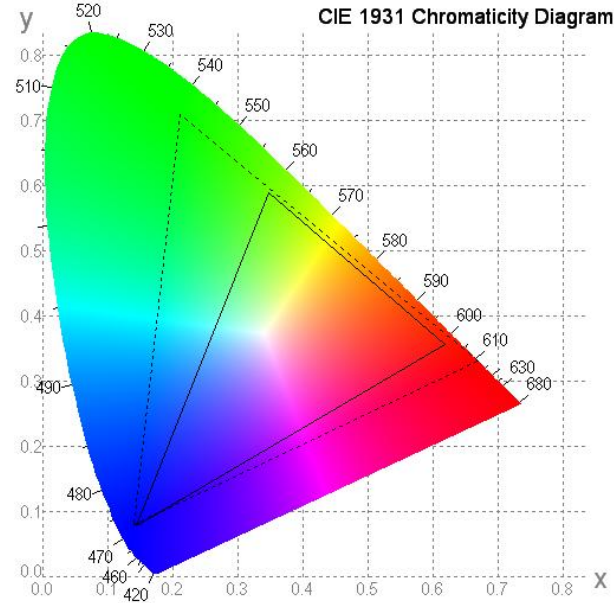

6.6. Definition of Surface Luminance, Uniformity and Transmittance

Using the transmissive mode measurement approach, measure the white screen luminance of the display panel and backlight.

6.6.1. Surface Luminance: $L_V = \text{average} (L_{P1}:L_{P9})$

6.6.2. Uniformity = $\text{Minimal} (L_{P1}:L_{P9}) / \text{Maximal} (L_{P1}:L_{P9}) * 100\%$

6.6.3. Transmittance = $L_V \text{ on LCD} / L_V \text{ on Backlight} * 100\%$

Note: Measuring machine: BM-7

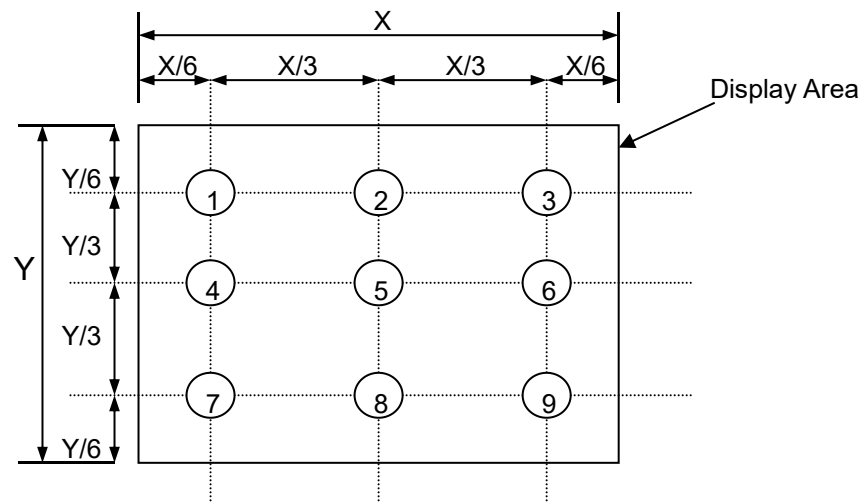

7. Interface Pins Definition

No.	Symbol	Function	Remark
1	VLED+	LED Input Terminal I(Anode).	
2	VLED+	LED Input Terminal I(Anode).	
3	VLED-	Ground (Cathode).	
4	VLED-	Ground (Cathode).	
5	GND	Ground.	
6	VCOM	Common voltage.	
7	DVDD	Power for Digital Circuit.	
8	NC(MODE)	DE/SYNC mode select.	Note1
9	DE	Data Input Enable.	
10	VS	Vertical Sync Input.	
11	HS	Horizontal Sync Input.	
12	B7	Blue data(MSB)	
13	B6	Blue data	
14	B5	Blue data	
15	B4	Blue data	
16	B3	Blue data	
17	B2	Blue data	
18	B1	Blue data	Note 2
19	B0	Blue data(LSB)	Note 2
20	G7	Green data(MSB)	
21	G6	Green data	
22	G5	Green data	
23	G4	Green data	
24	G3	Green data	
25	G2	Green data	
26	G1	Green data	Note 2
27	G0	Green data(LSB)	Note 2
28	R7	Red data(MSB)	
29	R6	Red data	
30	R5	Red data	
31	R4	Red data	
32	R3	Red data	
33	R2	Red data	
34	R1	Red data	Note 2
35	R0	Red data(LSB)	Note 2
36	GND	Ground.	
37	DCLK	Sample clock.	Note 3
38	GND	Ground.	
39	L/R	Left / right selection.	Note 4,5
40	NC(U/D)	Up / Down selection.	Note 4,5
41	VGH	NC(Gate ON Voltage)	

42	VGL	NC(Gate OFF Voltage.)	
43	AVDD	NC(Power for Analog Circuit)	
44	RESET	Global reset pin.	Note 6
45	NC	No connection.	
46	VCOM	NC(Common voltage.)	Note 7
47	NC	No connection.	
48	NC	No connection.	
49	NC	No connection.	
50	NC	No connection.	

Setting of scan control input		Scanning direction
U/D	L/R	
DVDD	DVDD	Up to down, left to right
GND	GND	Down to up, right to left
DVDD	GND	Up to down, right to left
GND	DVDD	Down to up, left to right

Note 1: Definition of scanning direction.

Refer to the figure as follow:

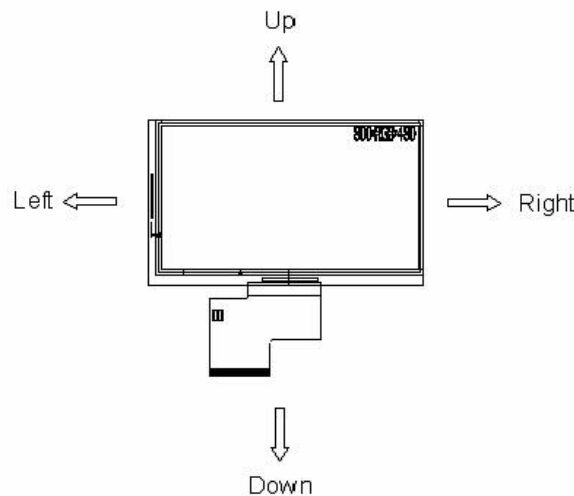

Note 2: Global reset pin. Active low to enter reset state. Suggest to connect with and RC reset circuit for stability. Normally pull high.

Note 3:

HV Mode, Mode="H", DE floating

DE Mode. Mode="L" and HS floating and VS floating

8. AC Characteristics

8.1. Timing Characteristics of input signals

Horizontal input timing diagram

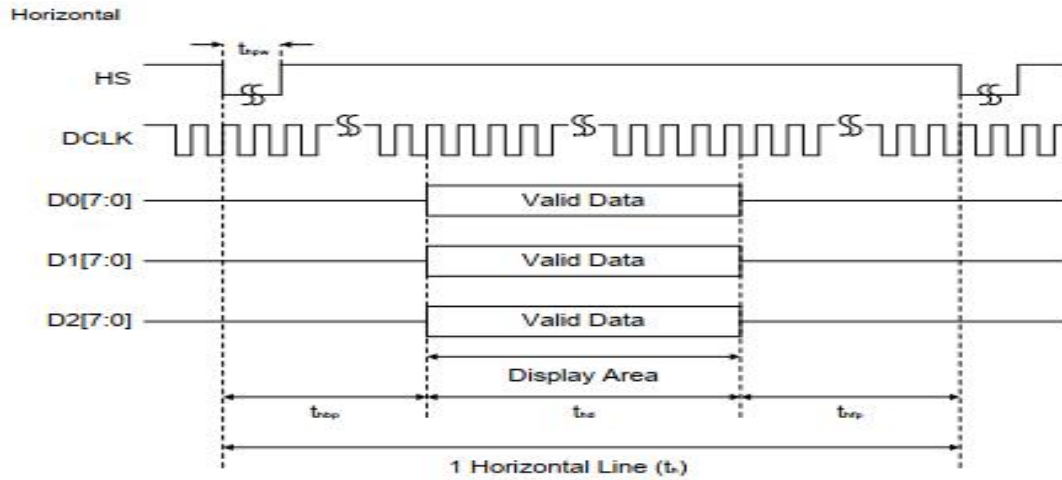

Figure 42 Horizontal Input timing at sync mode.

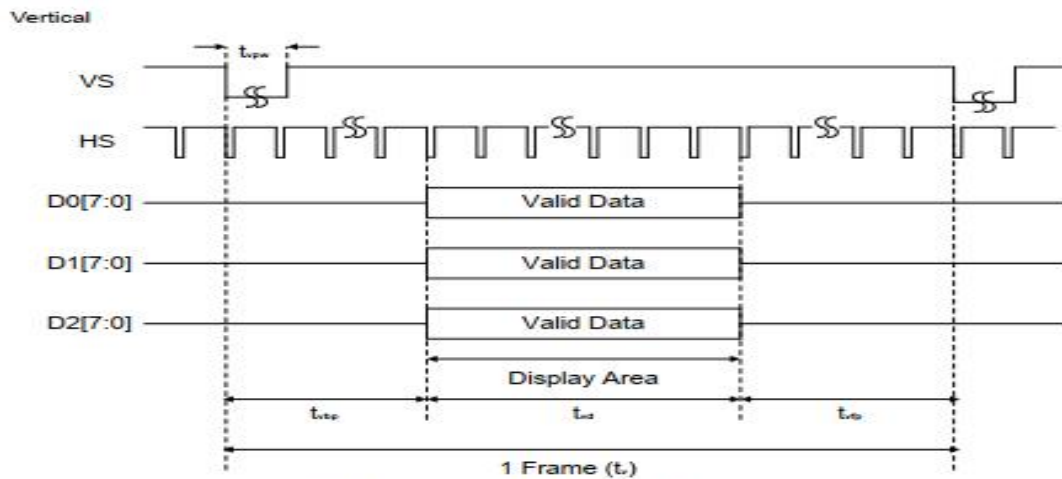

Figure 43 Vertical Input timing at sync mode.

640RGB X 480 Resolution Timing Table

Item	Symbol	Min.	Typ.	Max.	Unit	Remark	
DCLK Frequency	Fclk	18.4	20	23.4	MHz		
DCLK Period	Tclk	55	50	42	ns		
HSYNC	Period	T_h	486	680	598	DCLK	
	Time Display	T_{hdisp}	-	640	-	DCLK	
	Period Back	T_{hbp}	3	4	5	DCLK	By H_BLANKING setting
	Porch Front	T_{hfp}	20	24	30	DCLK	
	Porch Pulse	T_{hw}	10	12	13	DCLK	
	Width	T_v	133	493	321	HSYNC	
VSYNC	Period	T_v	133	493	321	HSYNC	
	Time Display	T_{vdisp}	-	480	-	HSYNC	
	Period Back	T_{vbp}	2	2	2	HSYNC	By V_BLANKING setting
	Porch Front	T_{vfp}	7	8	10	HSYNC	
	Porch Pulse	T_{vw}	3	3	3	HSYNC	
	Width	T_w	3	3	3	HSYNC	

8.1.5 Parallel RGB at DE only mode

It just needs DE signal only, when DE only mode enable.

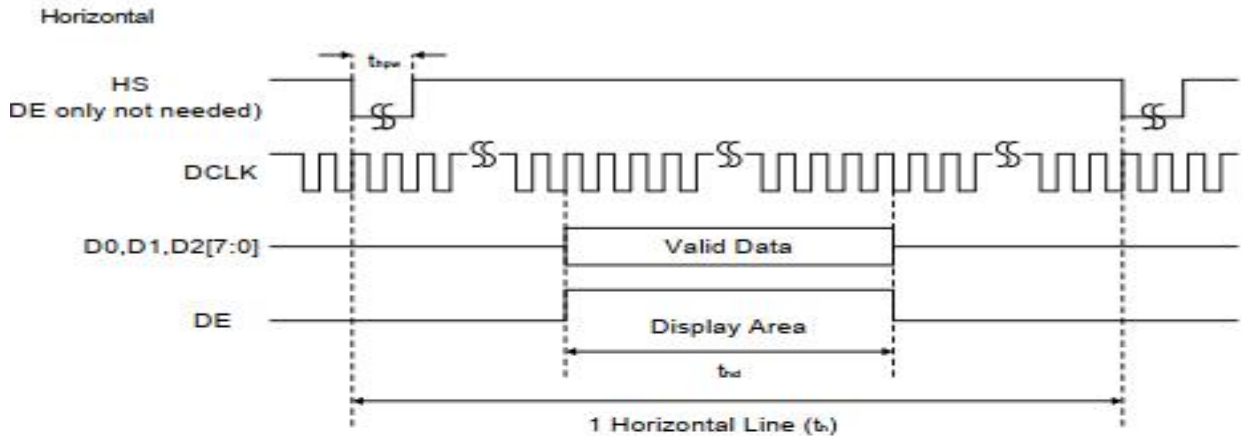

Figure 44 Horizontal Input timing at DE mode.

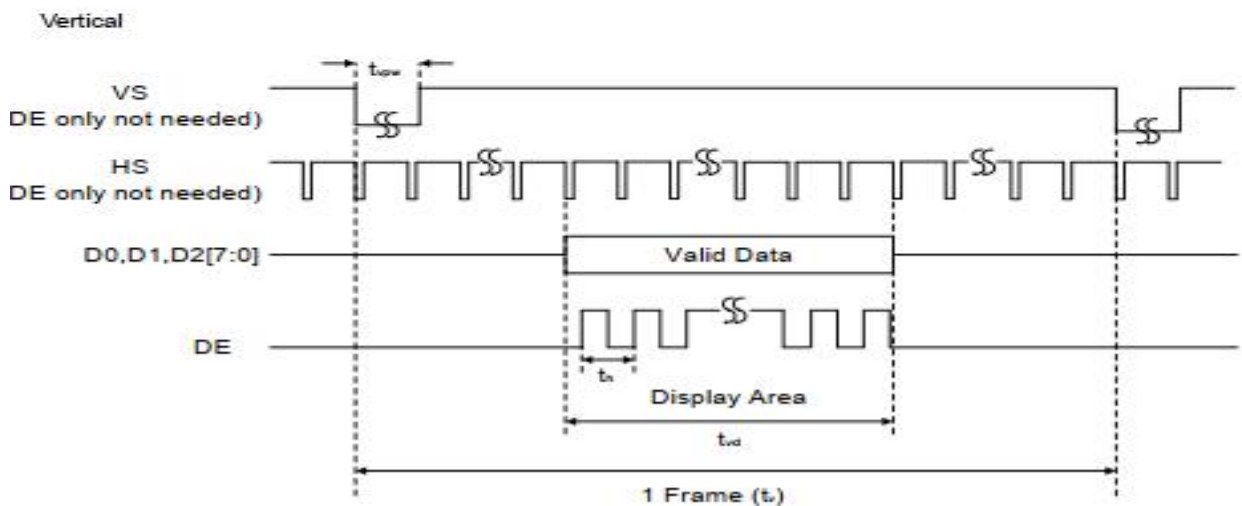

Figure 45 Vertical Input timing at DE mode.

640RGB X 480 Resolution Timing Table							
Item	Symbol	Min.	Typ.	Max.	Unit	Remark	
DCLK Frequency	Fclk	18.4	20	23.4	MHz		
DCLK Period	Tclk	55	50	42	ns		
HSYNC	Period	T_h	486	680	598	DCLK	
	Display	T_{hdisp}	-	640	-	DCLK	
	Back	T_{hbp}	3	4	5	DCLK	By H_BLANKING setting
	Porch	T_{hfp}	20	24	30	DCLK	
	Front	T_{hwp}	10	12	13	DCLK	
VSYNC	Period	T_v	133	493	321	HSYNC	
	Display	T_{vdisp}	-	480	-	HSYNC	
	Back	T_{vbp}	2	2	2	HSYNC	By V_BLANKING setting
	Porch	T_{vfp}	7	8	10	HSYNC	
	Front	T_{vwp}	3	3	3	HSYNC	

8.2. POWER ON/OFF SEQUENCE

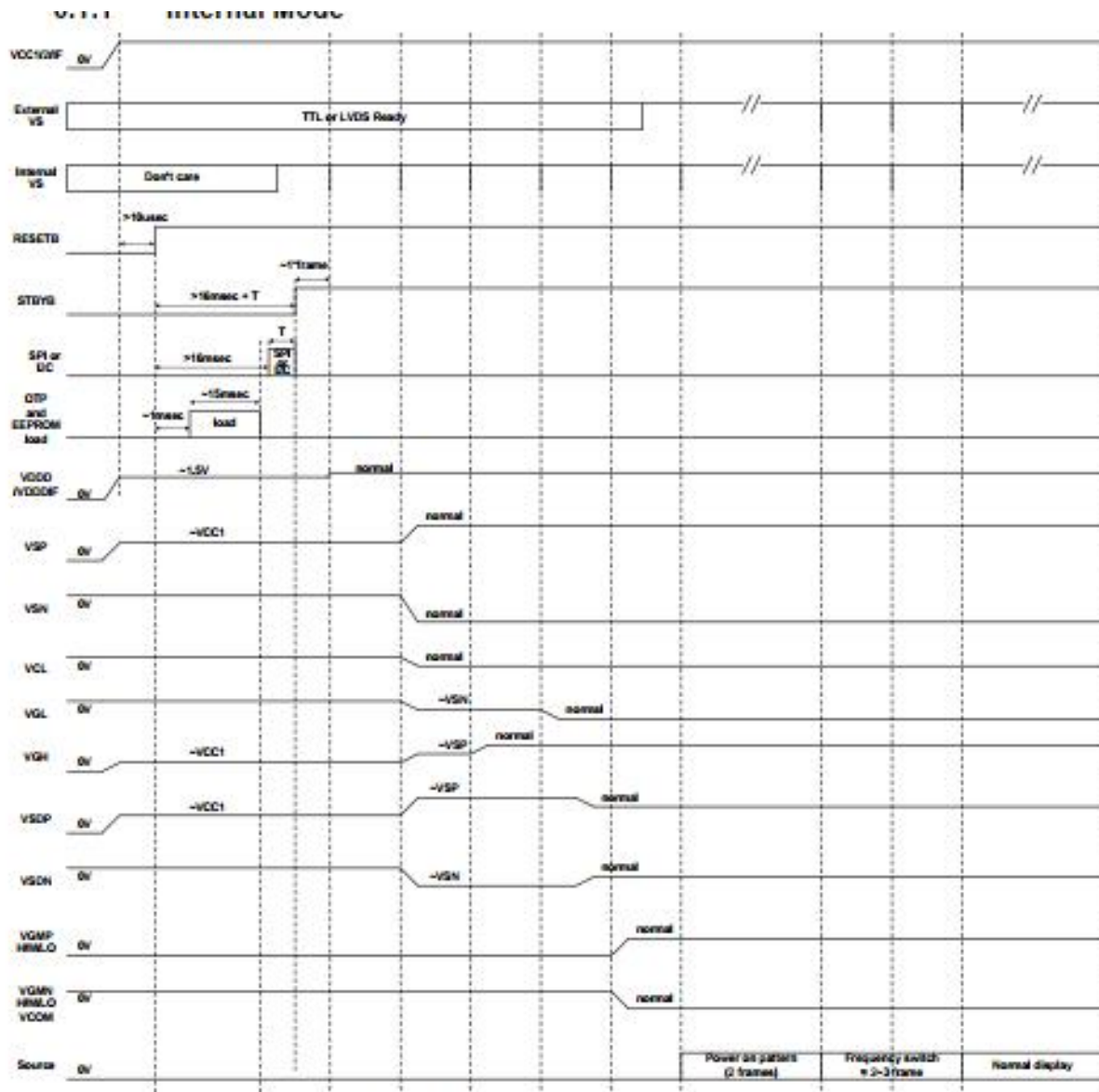

Figure 22 Power on sequence internal mode.

Note: If VSP and VSN are generated by PFM circuits.

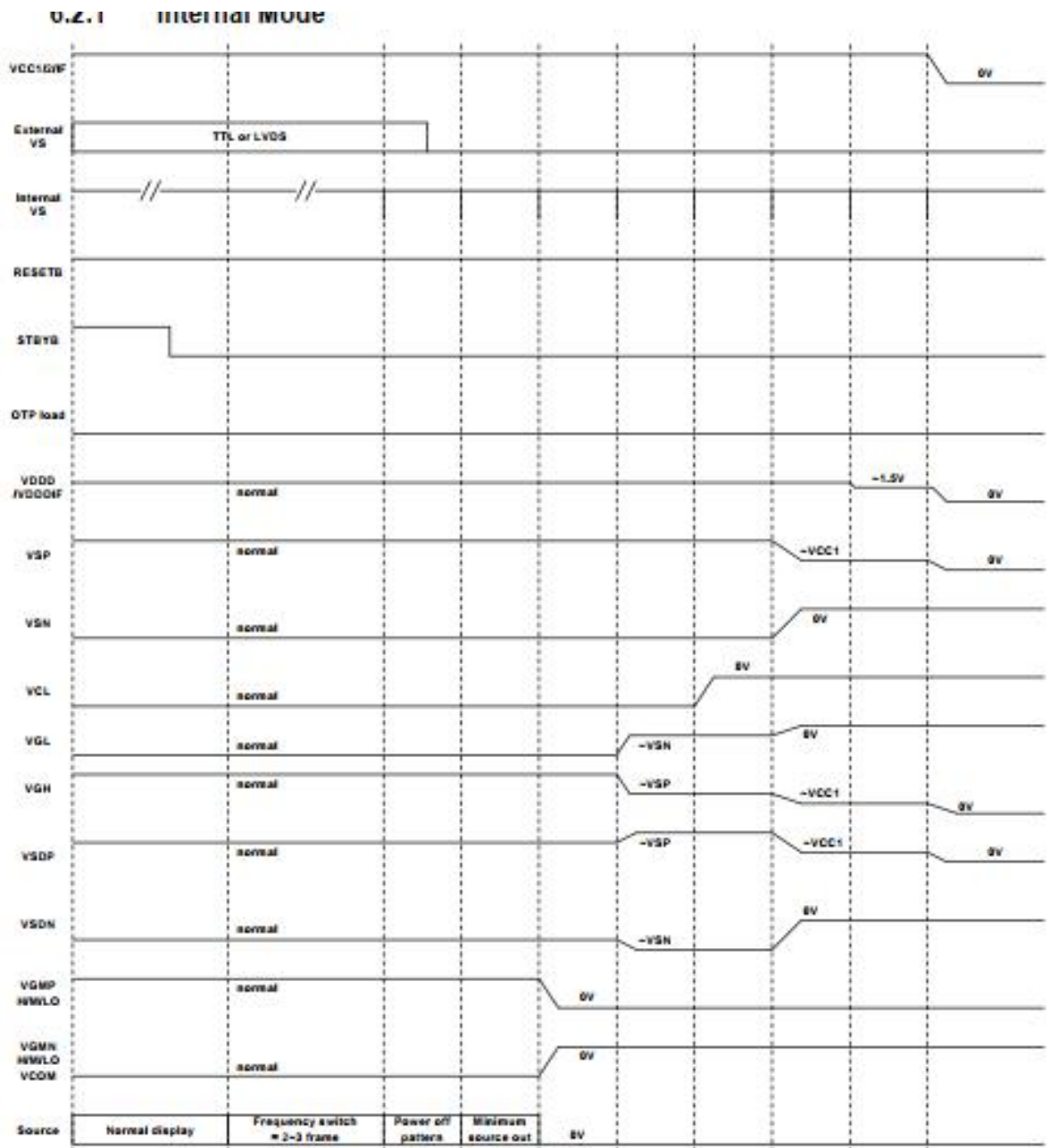

Figure 24 Power off sequence Internal mode.

Note: If VSP and VSN are generated by PFM circuits.

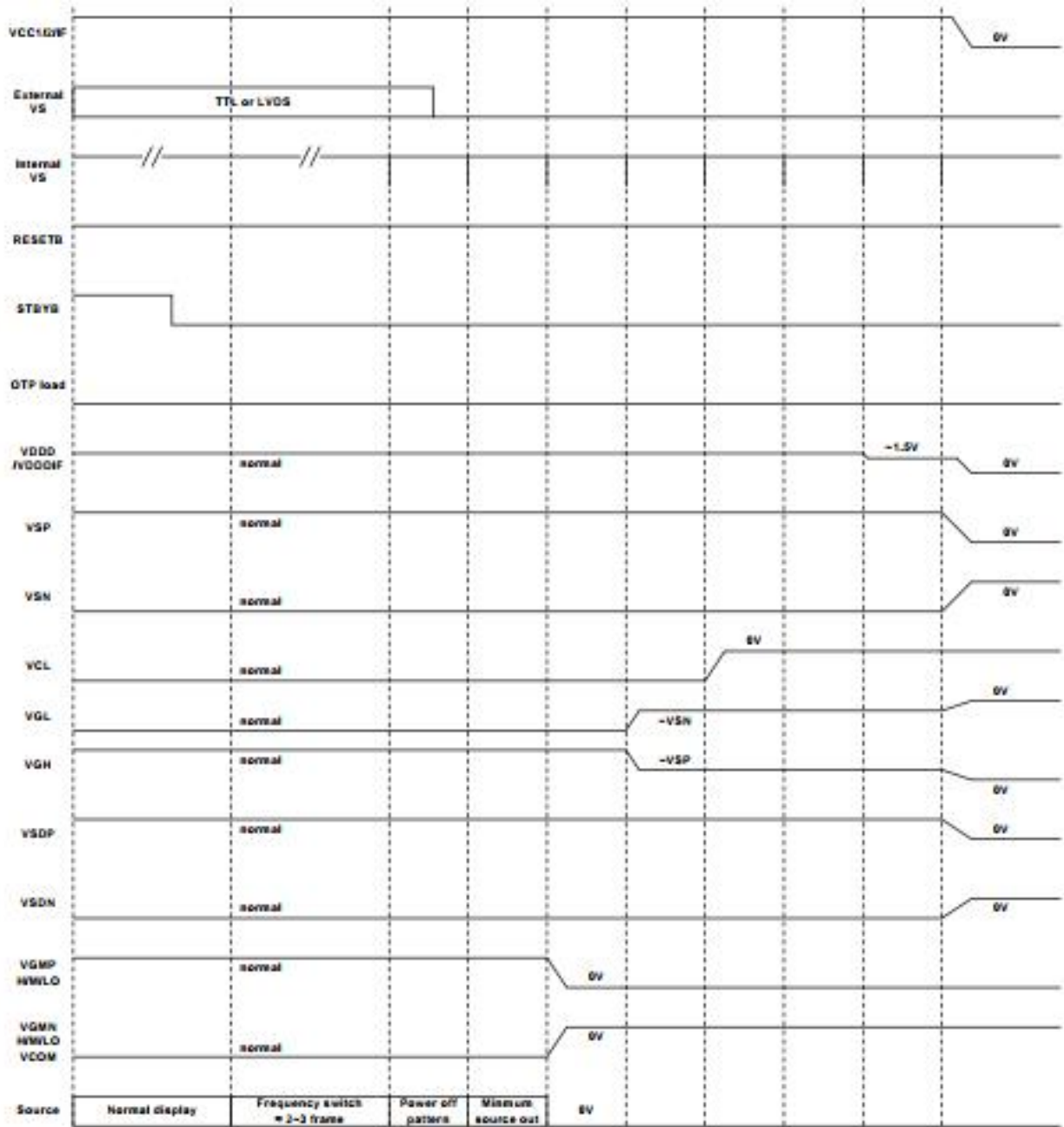

Figure 25 Power off sequence external mode.

Note: If VSP=VSDP and VSN=VSDN by external power supply, VGH and VGL generated by internal charge pump circuits.

9. Quality Assurance

9.1. Purpose

This standard for Quality Assurance assures the quality of LCD module products supplied to customer.

9.2. Standard for Quality Test

9.2.1. Sampling Plan:

GB2828.1-2012

Single sampling, general inspection level II

9.2.2. Sampling Criteria:

Visual inspection: AQL 1.5

Electrical functional: AQL 0.65.

9.2.3. Reliability Test:

Detailed requirement refer to Reliability Test Specification.

9.3. Nonconforming Analysis & Disposition

9.3.1. Nonconforming analysis:

9.3.1.1. Customer should provide overall information of non-conforming sample for their complaints.

9.3.1.2. After receipt of detailed information from customer, the analysis of nonconforming parts usually should be finished in one week.

9.3.1.3. If cannot finish the analysis on time, customer will be notified with the progress status.

9.3.2. Disposition of nonconforming:

9.3.2.1. Non-conforming product over PPM level will be replaced.

9.3.2.2. The cause of non-conformance will be analyzed. Corrective action will be discussed and implemented.

9.4. Agreement Items

Shall negotiate with customer if the following situation occurs:

9.4.1. There is any discrepancy in standard of quality assurance.

9.4.2. Additional requirement to be added in product specification.

9.4.3. Any other special problem.

9.5. Standard of the Product Visual Inspection

9.5.1. Appearance inspection:

9.5.1.1. The inspection must be under illumination about 1000 – 1500 lx, and the distance of view must be at 30cm ± 2cm.

9.5.1.2. The viewing angle should be 45° from the vertical line without reflection light or follows customer's viewing angle specifications.

9.5.1.3. Definition of area: A Zone: Active Area, B Zone: Viewing Area,

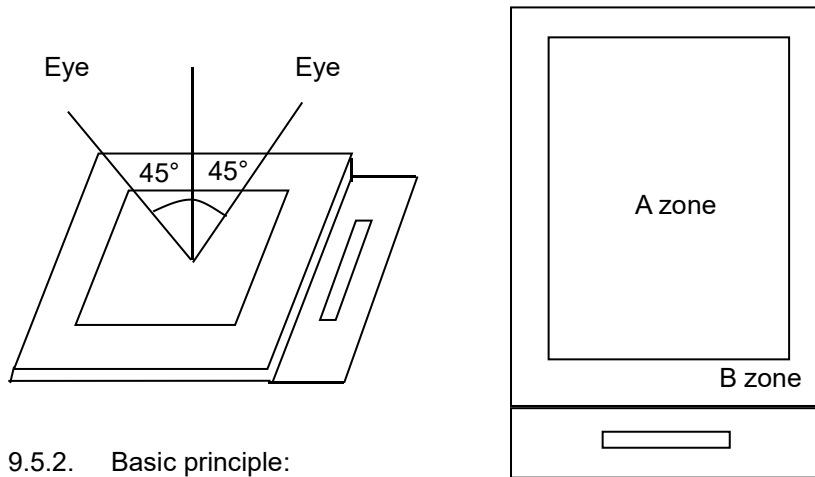

9.5.2. Basic principle:

- 9.5.2.1. A set of sample to indicate the limit of acceptable quality level must be discussed by both us and customer when there is any dispute happened.
- 9.5.2.2. New item must be added on time when it is necessary.

9.6. Inspection Specification

Inspection Specification These inspection standards shall be applied to LCD Module supplied by INNOLUX Optoelectronics Corporation. This model is only used in CE product, if it is used in other product applications; it still adopts this copy of specification. If there are any other product applications such as handwriting recognition, Industrial use, Medical use, Aerospace usage and so on, the specifications should be negotiated separately.

01 Definition of dot defect induced from the panel inside

- a) Bright dot: Dots appear bright and unchanged in size in which LCD panel is displaying under black pattern.
- b) Dark dot: Dots appear dark and unchanged in size in which LCD panel is displaying under pure red, green, blue picture.
- c) 2 dot adjacent = 1 pair = 2 dots

Picture:



No.	Display Inspection		
	Items		Criteria (Unit: mm)
02	Bright dot	Random	$N \leq 3$
		2 dots adjacent	$N \leq 0$
		3 dots adjacent	$N \leq 0$
	Dark dot	Random	$N \leq 4$
		2 dots adjacent	$N \leq 0$
		3 dots adjacent	$N \leq 0$
	Total bright dot and dark dot		

	Distance	Minimum Distance Between dark dots Minimum Distance Between dark and bright dots	5mm
		Tiny bright dot	visible through 6% ND filter $D \leq 0.3\text{mm}$, Ignore $0.3\text{mm} < D \leq 0.5\text{mm}$, $N \leq 34$ Distance $\geq 5\text{mm}$
Display failure (V-line/Cross line etc)			
Mura/Waving/Hot spot	Not visible through 5% ND filter in 50% gray or judge by limit sample if necessary		

*Note: Defect which is on the Black Matrix (outside of Active Area) are not considered as a defect.

No.	Appearance & Display inspection	
	Items	Criteria (Unit: mm)
03	Foreign Black/White/Bright Spot (Display & Appearance)	$D \leq 0.3\text{mm}$, Ignore, $0.25\text{mm} < D \leq 0.5\text{mm}$, $N \leq 4$ Distance $\geq 5\text{mm}$, It is shown in Fig. 2.
	Foreign Black/White/Bright Line (Display & Appearance)	$W \leq 0.05\text{ mm}$, Ignore $0.05 < W \leq 0.1\text{mm}$ $L \leq 5.0\text{ mm}$, $N \leq 4$ It is shown in Fig. 3.
	Polarizer Dent/Air Bubble	$D \leq 0.3\text{mm}$, Ignore $0.3\text{mm} < D \leq 0.5\text{mm}$, $N \leq 4$ Distance $\geq 5\text{mm}$
	Polarizer Scratches	$W \leq 0.07\text{mm}$, Ignore $0.07 < W \leq 0.1\text{mm}$ $L \leq 5.0\text{ mm}$, $N \leq 4$

Notes: If any specific defect is not included in the above defect table, this defect should be judged by INX/ODM/Brand customer discussion.

- 1. W: Width
- 2. L: Length
- 3. D: Average Diameter
- 4. N: Count

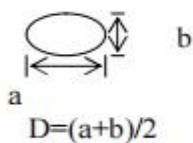

Fig. 2

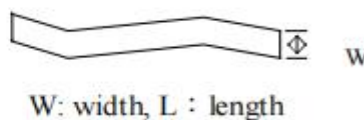
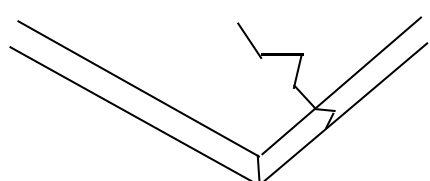
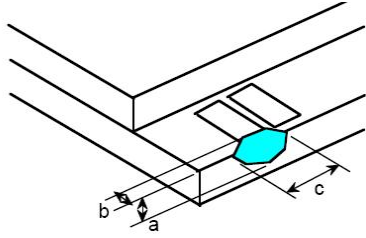
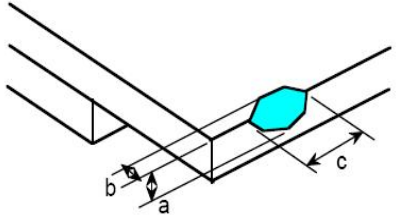
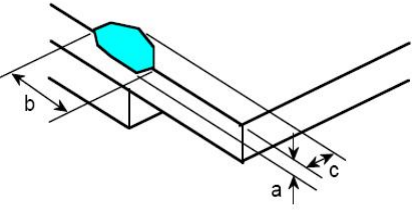
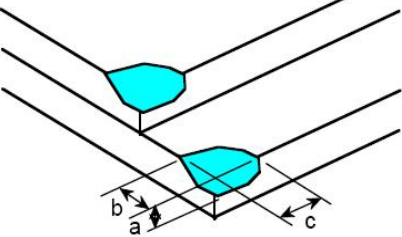
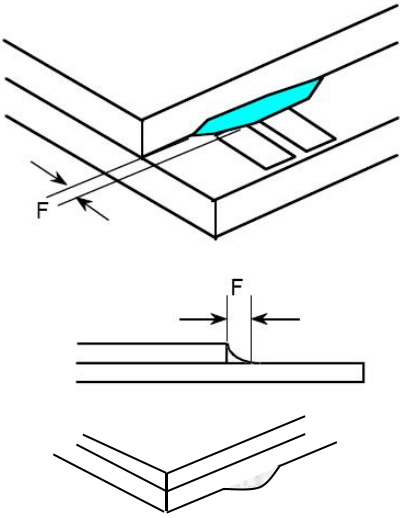
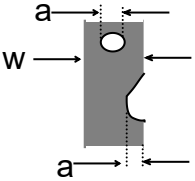

Fig. 3

No.	Item	Criteria (Unit: mm)
04	Glass Crack (Minor defect)	 Crack is potential to enlarge, any type is not allowed.

05	<p>Glass Chipping Pad Area: (Minor defect)</p> 	<table border="1"> <thead> <tr> <th>Length and Width</th> <th>Acc. Qty</th> </tr> </thead> <tbody> <tr> <td>$c > 3.0, b < 1.0$</td> <td>1</td> </tr> <tr> <td>$c < 3.0, b < 1.0$</td> <td>3</td> </tr> <tr> <td colspan="2" style="text-align: center;">$a < \text{Glass Thickness}$</td> </tr> </tbody> </table>	Length and Width	Acc. Qty	$c > 3.0, b < 1.0$	1	$c < 3.0, b < 1.0$	3	$a < \text{Glass Thickness}$			
Length and Width	Acc. Qty											
$c > 3.0, b < 1.0$	1											
$c < 3.0, b < 1.0$	3											
$a < \text{Glass Thickness}$												
06	<p>Glass Chipping Rear of Pad Area: (Minor defect)</p> 	<table border="1"> <thead> <tr> <th>Length and Width</th> <th>Acc. Qty</th> </tr> </thead> <tbody> <tr> <td>$c > 3.0, b < 1.0$</td> <td>1</td> </tr> <tr> <td>$c < 3.0, b < 1.0$</td> <td>2</td> </tr> <tr> <td>$c < 3.0, b < 0.5$</td> <td>4</td> </tr> <tr> <td colspan="2" style="text-align: center;">$a < \text{Glass Thickness}$</td> </tr> </tbody> </table>	Length and Width	Acc. Qty	$c > 3.0, b < 1.0$	1	$c < 3.0, b < 1.0$	2	$c < 3.0, b < 0.5$	4	$a < \text{Glass Thickness}$	
Length and Width	Acc. Qty											
$c > 3.0, b < 1.0$	1											
$c < 3.0, b < 1.0$	2											
$c < 3.0, b < 0.5$	4											
$a < \text{Glass Thickness}$												
07	<p>Glass Chipping Except Pad Area: (Minor defect)</p> 	<table border="1"> <thead> <tr> <th>Length and Width</th> <th>Acc. Qty</th> </tr> </thead> <tbody> <tr> <td>$c > 3.0, b < 1.0$</td> <td>1</td> </tr> <tr> <td>$c < 3.0, b < 1.0$</td> <td>2</td> </tr> <tr> <td>$c < 3.0, b < 0.5$</td> <td>4</td> </tr> <tr> <td colspan="2" style="text-align: center;">$a < \text{Glass Thickness}$</td> </tr> </tbody> </table>	Length and Width	Acc. Qty	$c > 3.0, b < 1.0$	1	$c < 3.0, b < 1.0$	2	$c < 3.0, b < 0.5$	4	$a < \text{Glass Thickness}$	
Length and Width	Acc. Qty											
$c > 3.0, b < 1.0$	1											
$c < 3.0, b < 1.0$	2											
$c < 3.0, b < 0.5$	4											
$a < \text{Glass Thickness}$												
08	<p>Glass Corner Chipping: (Minor defect)</p> 	<table border="1"> <thead> <tr> <th>Length and Width</th> <th>Acc. Qty</th> </tr> </thead> <tbody> <tr> <td>$c < 3.0, b < 3.0$</td> <td>Ignore</td> </tr> <tr> <td colspan="2" style="text-align: center;">$a < \text{Glass Thickness}$</td> </tr> </tbody> </table>	Length and Width	Acc. Qty	$c < 3.0, b < 3.0$	Ignore	$a < \text{Glass Thickness}$					
Length and Width	Acc. Qty											
$c < 3.0, b < 3.0$	Ignore											
$a < \text{Glass Thickness}$												

<p>09</p>	<p>Glass Burr: (Minor defect)</p> 	<table border="1" data-bbox="879 253 1350 342"> <thead> <tr> <th>Length</th> <th>Acc. Qty</th> </tr> </thead> <tbody> <tr> <td>$F < 1.0$</td> <td>Ignore</td> </tr> </tbody> </table> <p>Glass burr don't affect assemble and module dimension.</p>	Length	Acc. Qty	$F < 1.0$	Ignore
Length	Acc. Qty					
$F < 1.0$	Ignore					
<p>10</p>	<p>FPC Defect: (Minor defect)</p> 	<p>10.1 Dent, pinhole width $a < w/3$. (w: circuitry width.) 10.2 Open circuit is unacceptable. 10.3 No oxidation, contamination and distortion.</p>				
<p>11</p>	<p>Bezel</p>	<p>13.1 No rust, distortion on the Bezel. 13.2 No visible fingerprints, stains or other contamination.</p>				
<p>12</p>	<p>Touch Panel</p>	<p>D: Diameter W: width L: length 14.1 Spot: $D < 0.25$ is acceptable $0.25 \leq D \leq 0.4$ 2dots are acceptable and the distance between defects should more than 10 mm. $D > 0.4$ is unacceptable 14.2 Dent: $D > 0.40$ is unacceptable 14.3 Scratch: $W \leq 0.03$, $L \leq 10$ is acceptable, $0.03 < W \leq 0.10$, $L \leq 10$ is acceptable Distance between 2 defects should more than 10 mm. $W > 0.10$ is unacceptable.</p>				
<p>13</p>	<p>LCD Ripple</p>	<p>Touch the touch panel, cannot see the LCD ripple. Pen: R 0.8mm silicon rubber. Operation Force:120g</p>				

14	PCB	16.1 No distortion or contamination on PCB terminals. 16.2 All components on PCB must same as documented on the BOM/component layout. 16.3 Follow IPC-A-600F.
15	Soldering	Follow IPC-A-610C standard
16	Electrical Defect (Major defect)	The below defects must be rejected. 18.1 Missing vertical / horizontal segment, 18.2 Abnormal Display. 18.3 No function or no display. 18.4 Current exceeds product specifications. 18.5 LCD viewing angle defect. 18.6 No Backlight. 18.7 Dark Backlight. 18.8 Touch Panel no function.

Remark: LCD Panel Broken shall be rejected. Defect out of LCD viewing area is acceptable.

9.7. Classification of Defects

- 9.7.1. Visual defects (Except no / wrong label) are treated as minor defect and electrical defect is major.
- 9.7.2. Two minor defects are equal to one major in lot sampling inspection.

9.8. Identification/marketing criteria

Any unit with illegible / wrong /double or no marking/ label shall be rejected.

9.9. Packing

- 9.9.1. There should be no damage of the outside carton box, each packaging box should have one identical label.
- 9.9.2. Modules inside package box should have compliant mark.
- 9.9.3. All direct package materials shall offer ESD protection.

Note1: Bright dot is defined as the defective area of the dot is larger than 50% of one sub-pixel area.

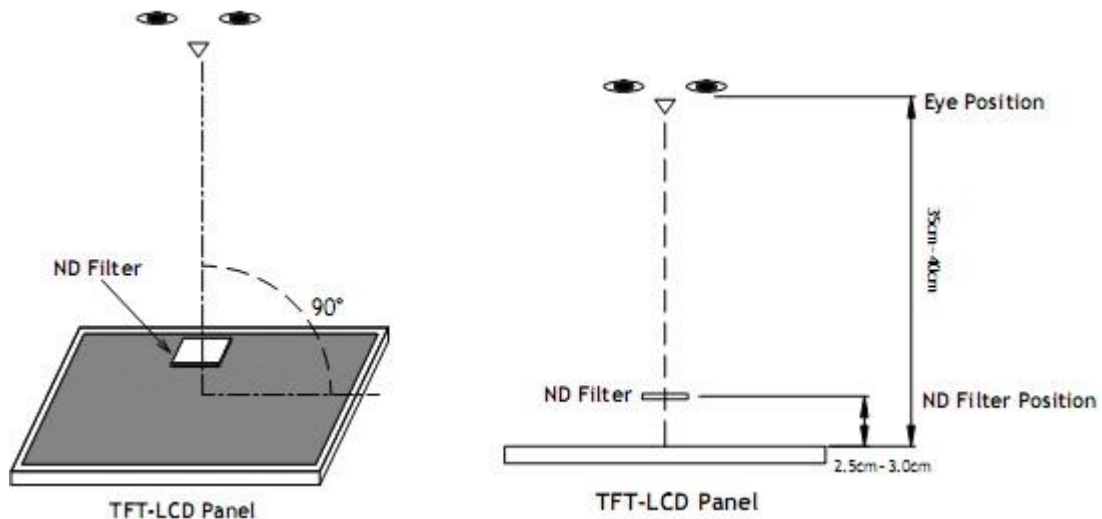

Bright dot: The bright dot size defect at black display pattern. It can be recognized by 2% transparency of filter when the distance between eyes and panel is $350\text{mm} \pm 50\text{mm}$.

Dark dot: Cyan, Magenta or Yellow dot size defect at white display pattern. It can be recognized by 5% transparency of filter when the distance between eyes and panel is $350\text{mm} \pm 50\text{mm}$.

Note2: Mura on display which appears darker / brighter against background brightness on parts of display area.

10. Reliability Specification

No	Item	Condition	Quantity	Criteria
1	High Temperature Operating	70°C, 96Hrs	2	GB/T2423.2-2008
2	Low Temperature Operating	-20°C, 96Hrs	2	GB/T2423.1-2008
3	High Humidity	50°C, 90%RH, 96Hrs	2	GB/T2423.3-2016

4	High Temperature Storage	80°C, 96Hrs	2	GB/T2423.2-2008
5	Low Temperature Storage	-30°C, 96Hrs	2	GB/T2423.1-2008
6	Thermal Cycling Test	-30°C, 60min~80°C, 60min, 20 cycles.	2	GB/T2423.22-2012
7	Packing vibration	Frequency range:10Hz~50Hz Acceleration of gravity:5G X, Y, Z 30 min for each direction.	2	GB/T5170.14-2009
8	Electrical Static Discharge	Air: $\pm 8\text{KV}$ 150pF/330 Ω 5 times	2	GB/T17626.2-2018
		Contact: $\pm 4\text{KV}$ 150pF/330 Ω 5 times		
9	Drop Test (Packaged)	Height:80 cm,1 corner, 3 edges, 6 surfaces.	2	GB/T2423.8-1995

Note 1: T_a is the ambient temperature of samples.

Note 2: T_s is the temperature of panel's surface.

Note 3: In the standard condition, there shall be no practical problem that may affect the display function. After the reliability test, the product only guarantees operation, but doesn't guarantee all the cosmetic specification.

Note 4: Before cosmetic and function test, the product must have enough recovery time, at least 2 hours at room temperature.

Note 5: One product only can use to conduct one Item test

11. Precautions and Warranty

11.1. Safety

- 11.1.1. The liquid crystal in the LCD is poisonous. Do not put it in your mouth. If the liquid crystal touches your skin or clothes, wash it off immediately using soap and water.
- 11.1.2. Since the liquid crystal cells are made of glass, do not apply strong impact on them. Handle with care.

11.2. Handling

- 11.2.1. Reverse and use within ratings in order to keep performance and prevent damage.
- 11.2.2. Do not wipe the polarizer with dry cloth, as it might cause scratch. If the surface of the LCD needs to be cleaned, wipe it swiftly with cotton or other soft cloth soaked with petroleum IPA, do not use other chemicals.

11.3. Storage

- 11.3.1. Do not store the LCD module beyond the specified temperature ranges.
- 11.3.2. Strong light exposure causes degradation of polarizer and color filter.

11.4. Metal Pin (Apply to Products with Metal Pins)

11.4.1. Pins of LCD and Backlight

11.4.1.1. Solder tip can touch and press on the tip of Pin LEAD during the soldering

11.4.1.2. Recommended Soldering Conditions

Solder Type: Sn96.3~94-Ag3.3~4.3-Cu0.4~1.1

Maximum Solder Temperature: 370°C

Maximum Solder Time: 3s at the maximum temperature

Recommended Soldering Temp: 350±20°C

Typical Soldering Time: ≤3s

11.4.1.3. Solder Wetting

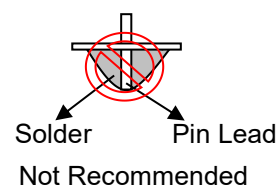
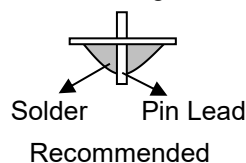

11.4.2. Pins of EL

11.4.2.1. Solder tip can touch and press on the tip of EL leads during soldering.

11.4.2.2. No Solder Paste on the soldering pad on the motherboard is recommended.

11.4.2.3. Recommended Soldering Conditions

Solder type: Nippon Alimit Leadfree SR-34, size 0.5mm

Recommended Solder Temperature: 270~290°C

Typical Soldering Time: ≤2s

Minimum solder distance from EL lamp (body):2.0mm

11.4.2.4. No horizontal press on the EL leads during soldering.

11.4.2.5. 180° bend EL leads three times is not allowed.

11.4.2.6. Solder Wetting

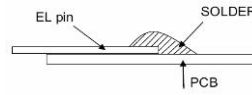

Recommended

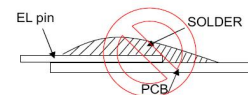

Not Recommended

11.4.2.7. The type of the solder iron:

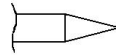

Recommended

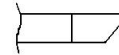

Not Recommended

11.4.2.8. Solder Pad

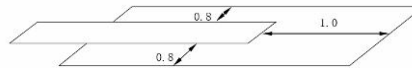

11.5. Operation

- 11.5.1. Do not drive LCD with DC voltage
- 11.5.2. Response time will increase below lower temperature
- 11.5.3. Display may change color with different temperature
- 11.5.4. Mechanical disturbance during operation, such as pressing on the display area, may cause the segments to appear “fractured”.
- 11.5.5. Do not connect or disconnect the LCM to or from the system when power is on.
- 11.5.6. Never use the LCM under abnormal condition of high temperature and high humidity.
- 11.5.7. Module has high frequency circuits. Sufficient suppression to the electromagnetic interface shall be done by system manufacturers. Grounding and shielding methods may be important to minimize the interference.
- 11.5.8. Do not display the fixed pattern for long time (we suggest the time not longer than half of one hour) because it may develop image sticking due to the TFT structure.

11.6. Static Electricity

- 11.6.1. CMOS LSIs are equipped in this unit, so care must be taken to avoid the electro-static charge, by ground human body, etc.
- 11.6.2. The normal static prevention measures should be observed for work clothes and benches.
- 11.6.3. The module should be kept into anti-static bags or other containers resistant to static for storage.

11.7. Limited Warranty

- 11.7.1. Our warranty liability is limited to repair and/or replacement. We will not be responsible for any consequential loss.
- 11.7.2. If possible, we suggest customer to use up all modules in six months. If the module storage time over twelve months, we suggest that recheck it before the module be used.
- 11.7.3. After the product shipped, any product quality issues must be feedback within three months, otherwise, we will not be responsible for the subsequent or consequential events.

12. Packaging

TBD