



深圳市宇华微科技有限公司

PRODUCT SPECIFICATION

Doc. Number:

- Tentative Specification
- Preliminary Specification
- Approval Specification

MODELNO.:YH070MSA-4003

SUFFIX:L01

Customer:	
APPROVED BY	SIGNATURE
Name / Title _____	
Note : _____	
<p>Please return 1 copy for your confirmation with your signature and comments .</p>	

Approved By	Checked By	Prepared By

Table of Contents

List	Description	Page No.
	Cover	1
	Revision Record	2
	Table of Contents	3
1	Scope	4
2	General Information	4
3	External Dimensions	5
4	Interface Description	6
5	Electrical specification	7
6	Absolute Maximum Ratings	8
7	Timing Characteristics	9
8	Backlight Characteristics	13
9	Optical Characteristics	14
10	Reliability Test Conditions and Methods	16
11	Inspection Standard	17
12	Handling Precautions	22
13	Precaution for Use	23
14	Packing Method	23

1. Scope

This specification defines general provisions as well as inspection standards for TFT module supplied by YHW electronics.

If the event of unforeseen problem or unspecified items may occur, naturally shall negotiate and agree to solution

2. General Information

TITEM	STANDARD VALUES	UNITS
LCD type	7.0" TFT	--
Dot arrangement	1024(RGB) × 600	dots
Color filter array	RGB vertical stripe	--
Display mode	Normally Black , Transmissive	-
Gray Scale Inversion Direction	ALL	--
Eyes Viewing Direction	80/80/80/80	
Module size	165(W) × 100(H) × 5.5(T)	mm
Active area	154.21(W) × 85.92(H)	mm
Dot pitch	0.1506(W) × 0.1432(H)	mm
Interface	LVDS	--
Operating temperature	-20 ~ +70	°C
Storage temperature	-30 ~ +80	°C
Back Light	27White LED	--
Weight	TBD	g

3. External Dimensions

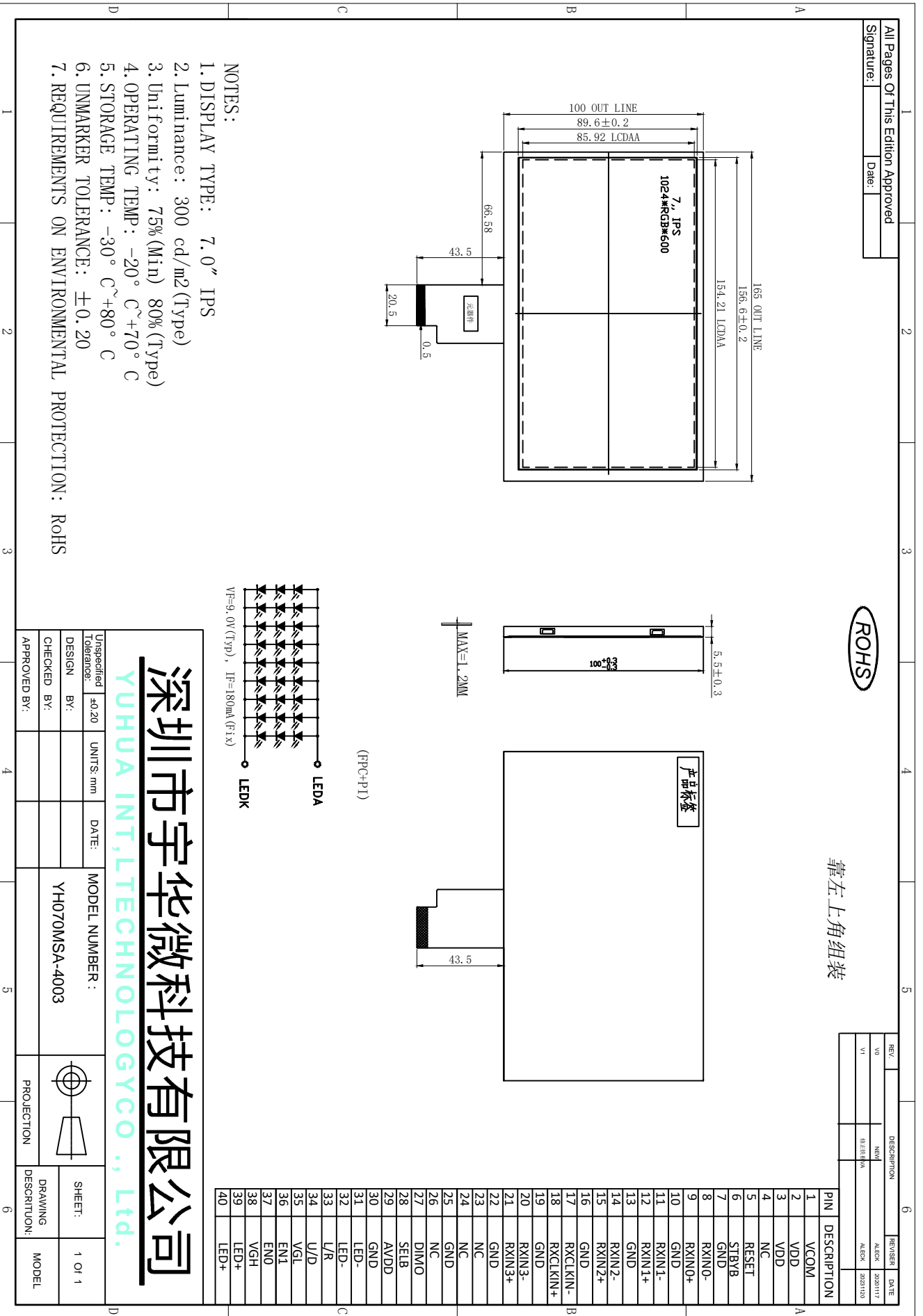

4. Interface Description

Pin No.	Symbol	I/O	Function	Remark
1	VCOM	P	Common Voltage	
2	VDD	P	Power Voltage for digital circuit	
3	VDD	P	Power Voltage for digital circuit	
4	NC	---	No connection	
5	Reset	I	Global reset pin	
6	STBYB	I	Standby mode, Normally pulled high STBYB = "1", normal operation STBYB = "0", timing controller, source driver will turn off, all output are High-Z	
7	GND	P	Ground	
8	RXIN0-	I	- LVDS differential data input	
9	RXIN0+	I	+ LVDS differential data input	
10	GND	P	Ground	
11	RXIN1-	I	- LVDS differential data input	
12	RXIN1+	I	+ LVDS differential data input	
13	GND	P	Ground	
14	RXIN2-	I	- LVDS differential data input	
15	RXIN2+	I	+ LVDS differential data input	
16	GND	P	Ground	
17	RXCLKIN-	I	- LVDS differential clock input	
18	RXCLKIN+	I	+ LVDS differential clock input	
19	GND	P	Ground	
20	RXIN3-	I	- LVDS differential data input	
21	RXIN3+	I	+ LVDS differential data input	

22	GND	P	Ground	
23	NC	---	No connection	
24	NC	---	No connection	
25	GND	P	Ground	
26	NC	---	No connection	
27	DIMO	O	Backlight CABC controller signal output	
28	SELB	I	6bit/8bit mode select	Note1
29	AVDD	P	Power for Analog Circuit	
30	GND	P	Ground	
31	LED-	P	LED Cathode	
32	LED-	P	LED Cathode	
33	L/R	I	Horizontal inversion	Note3
34	U/D	I	Vertical inversion	Note3
35	VGL	P	Gate OFF Voltage	
36	CABCEN1	I	CABC H/W enable	Note2
37	CABCEN0	I	CABC H/W enable	Note2
38	VGH	P	Gate ON Voltage	
39	LED+	P	LED Anode	
40	LED+	P	LED Anode	

I: input, O: output, P: Power

Note1: If LVDS input data is 6 bits ,SELB must be set to High;

If LVDS input data is 8 bits ,SELB must be set to Low.

Note2: When CABC_EN="00", CABC OFF.

When CABC_EN="01", user interface image.

When CABC_EN="10", still picture.

When CABC_EN="11", moving image.

When CABC off, don't connect DIMO, else connect it to backlight.

Note3: When L/R="0", set right to left scan direction.

When L/R="1", set left to right scan direction.

When U/D="0", set top to bottom scan direction.

When U/D="1", set bottom to top scan direction.

5. Electrical specification

Item	Symbol	Min.	Typ.	Max.	Unit	Remark
Input signal Voltage	VCOM	-	3.685	-	V	-
Logic Supply Voltage	DVDD	2.3	3.3	3.6	V	-
Analog Supply Voltage	AVDD	-	11.0	-	V	
Low Supply Voltage	VGL	-	-11	-	V	
High Supply Voltage	VGH	-	18	-	V	
Output High Voltage	VIH	0.7XVDD	-	VDD	V	-
Output Low Voltage	VIL	0	-	0.3xVDD	V	-

Note 1: Please adjust VCOM to make the flicker level be minimum. Typ VCOM 电压值
只做参考, 具体以实际效果为准 (根据FLICKER 状态可调整)

Note 2: The gate IC is the HX8696-A, The source IC is the HX8282-A

6. Absolute Maximum Ratings

Item	Symbol	Min.	Max.	Unit
Logic Supply Voltage	DVDD	-0.5	5	V
Analog Supply Voltage	AVDD	-0.5	15	V
High Supply Voltage	VGH	-0.3	40	V
Low Supply Voltage	VGL	-20	0.3	V
Operating Temperature	TOP	-20	70	°C
Storage Temperature	TST	-30	80	°C

7. Timing Characteristics

7.1 POWER ON/OFF SEQUENCE

To prevent the device damage from latch up, the power on/off sequence shown below must be followed.

Power on: VDD, GND _ AVDD, AGND _ V1 to V14

Power off: V1 to V14 _ AVDD, AGND_ VDD, GND

Power on/off control

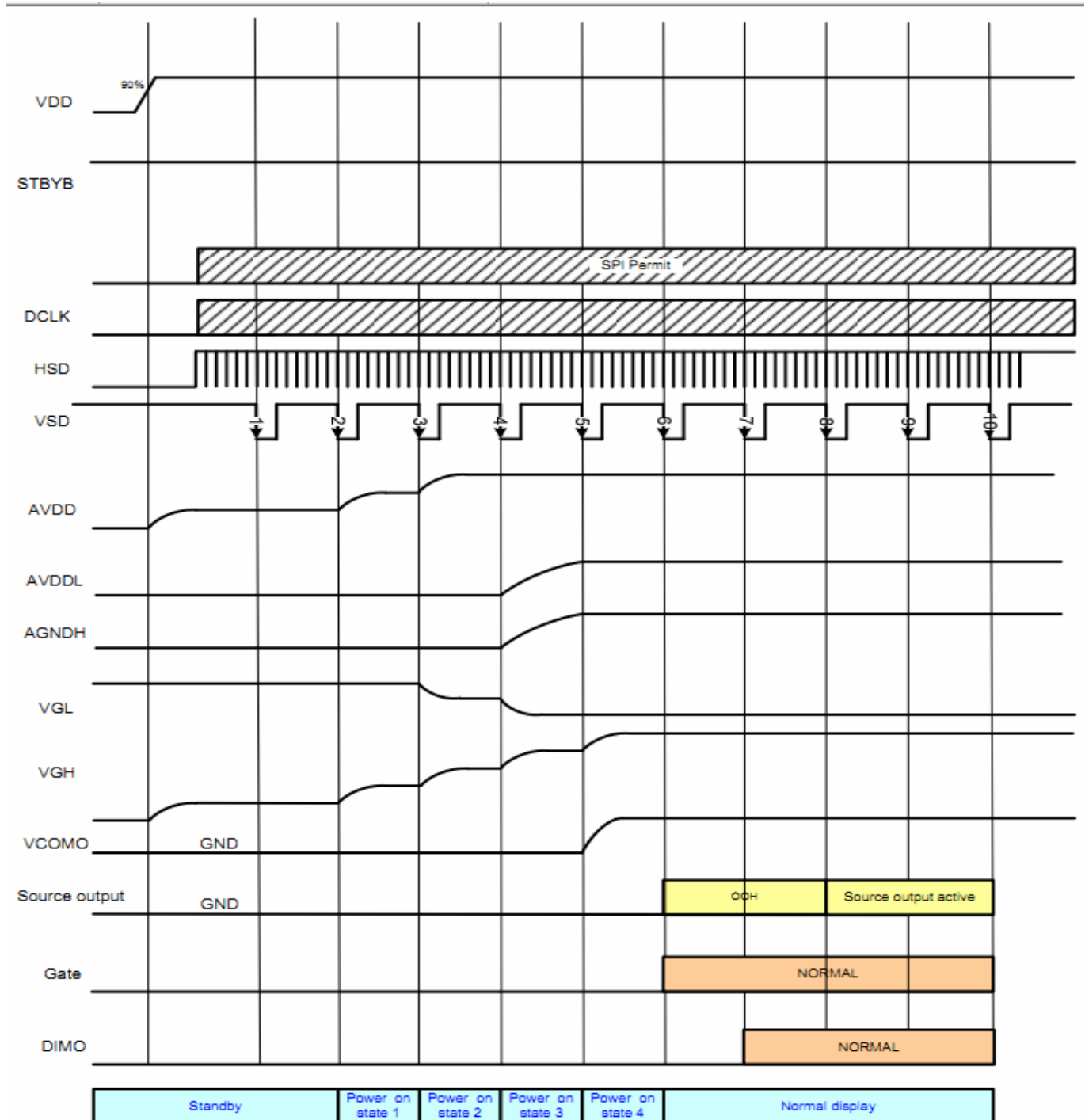

Power on timing sequence

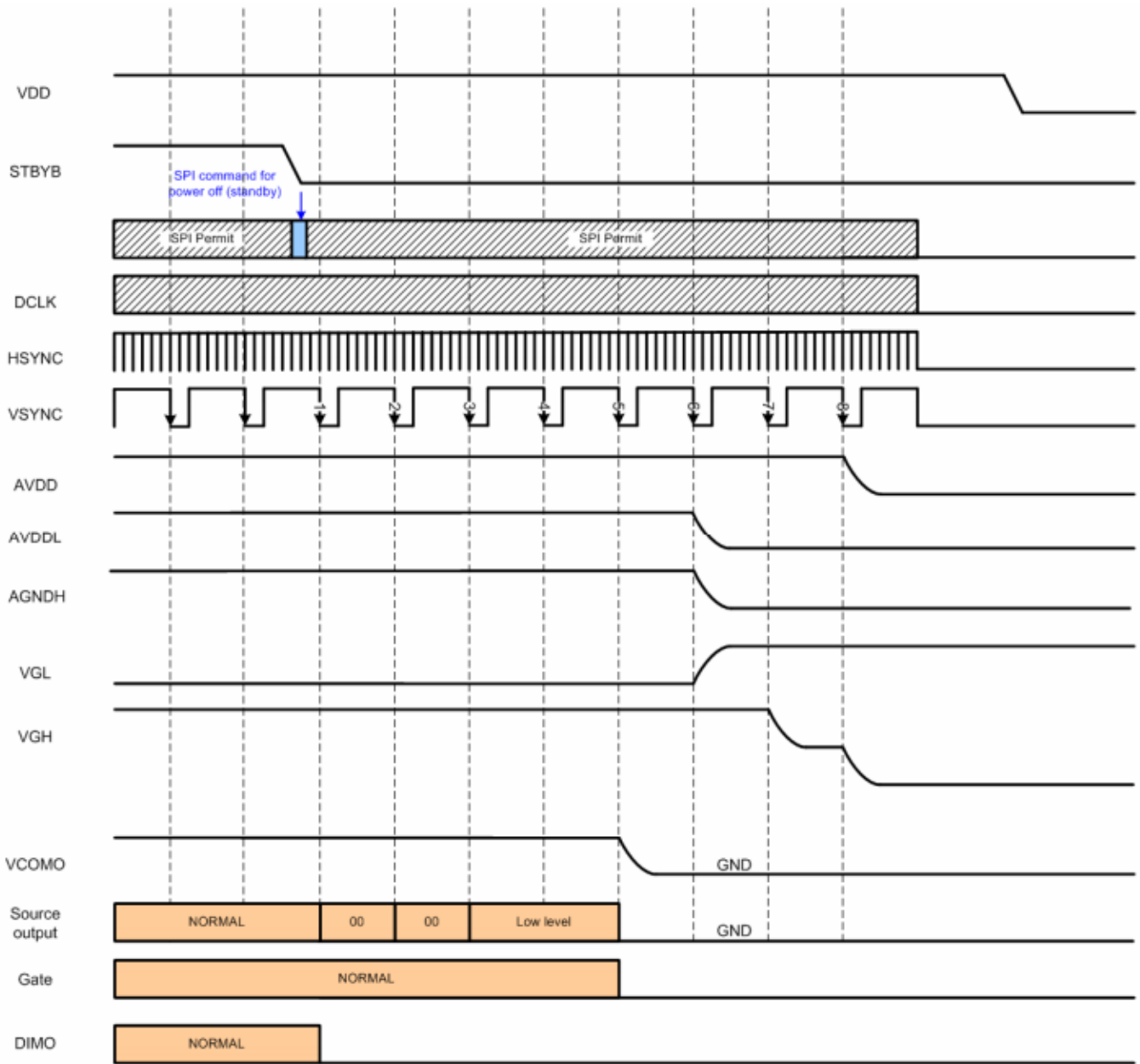

Power off timing sequence

7.2 INPUT SIGNAL TIMING

7.2.1 DC electrical characteristics

TTL mode DC electrical characteristics

(VDD=3.0~3.6V, AVDD=6.5~13.5V, GND=AGND=0V, TA=-20°C~+85°C)

Parameter	Symbol	Spec.			Unit	Condition
		Min.	Typ.	Max.		
Power supply voltage	VDD	3.0	-	3.6	V	-
Power supply voltage	AVDD	6.5	-	13.5	V	-
Power supply voltage	AVDDL	6.5	-	13.5	V	Full range application
		-	V8+0.1	-	V	Half AVDD application
Power supply voltage	AGNDH	0			V	Full range application
		-	V7-0.1	-	V	Half AVDD application
AVDD regulate output	AVDDG	8.9	9	9.1	V	AVDD=10 V, VDD=3.3V, with Resistor loading $\geq 30K$ Ohm, and Capacitor loading $\geq 4.7\mu F$
Low level input voltage	V _{IL}	0	-	0.3VDD	V	For digital circuit
High level input voltage	V _{IH}	0.7VDD	-	VDD	V	For digital circuit
Output low voltage	V _{OL}	-	-	GND+0.4	V	I _{OL} =400 μ A
Output high voltage	V _{OH}	VDD-0.4	-	-	V	I _{OH} =-400 μ A
Pull low/high resistance	R _i	200	250	300	k Ω	For the digital input pin @VDD=3.3V
Input leakage current	I _{li}	-	-	± 1	μ A	For digital circuit
Digital Operation current	I _{dd}	-	12	20	mA	Fclk=50MHz, LD=48KHz, VDD=3.3V, No load
Digital stand-by current	I _{st1}	-	10	50	μ A	Clock & all functions are stopped
Analog Operating current	I _{dda}	-	8	10	mA	No load, Fclk=50MHz, LD=48KHz @ AVDD=10V, V1=8V, V14=0.4V
Analog Stand-by current	I _{st2}	-	10	50	μ A	No load, clock & all functions are stopped
Input level of V1~V7	V _{ref1}	0.4AVDD	-	AVDD-0.1	V	Gamma correction voltage input
Input level of V8~V14	V _{ref2}	0.1	-	0.6AVDD	V	Gamma correction voltage input
Output Voltage deviation	V _{od1}	-	± 20	± 35	mV	V _o =AGND+0.1V~AGND+0.5V & V _o =AVDD-0.5V~AVDD-0.1V
Output Voltage deviation	V _{od2}	-	± 15	± 20	mV	V _o =AGND+0.5V~AVDD-0.5V
Output Voltage Offset between Chips	V _{oc}	-	-	± 20	mV	V _o =AGND+0.5V~AVDD-0.5V
Dynamic Range of Output	V _{dr}	0.1	-	AVDD-0.1	V	SO1~SO1200
Sinking Current of Outputs	I _{OLy}	80	-	-	μ A	SO1~SO1200; V _o =0.1V vs. 1.0V, AVDD=13.5V
Driving Current of Outputs	I _{OHy}	80	-	-	μ A	SO1~SO1200; V _o =0.1V vs. 12.5V, AVDD=13.5V
Resistance of Gamma Table	R _g	0.7*R _n	1.0*R _n	1.3*R _n	Ω	R _n : Internal gamma resistor

Table 9.2: DC electrical characteristics

7.2.2AC ELECTRICAL CHARACTERISTICS

TTL mode AC electrical characteristics

Parameter	Symbol	Spec.			Unit	Condition
		Min.	Typ.	Max.		
VDD Power On Slew rate	T_{POR}	-	-	20	ms	From 0V to 90% VDD
GRB pulse width	T_{GRB}	50	-	-	μ s	-
DCLK cycle time	T_{cph}	14	-	-	ns	-
DCLK pulse duty	T_{cwh}	40	50	60	%	-
VSD setup time	T_{vst}	5	-	-	ns	-
VSD hold time	T_{vhhd}	5	-	-	ns	-
HSD setup time	T_{hst}	5	-	-	ns	-
HSD hold time	T_{hhhd}	5	-	-	ns	-
Data set-up time	T_{dsu}	5	-	-	ns	D0[7:0], D1[7:0], D2[7:0] to DCLK
Data hold time	T_{dhd}	5	-	-	ns	D0[7:0], D1[7:0], D2[7:0] to DCLK
DE setup time	T_{esu}	5	-	-	ns	-
DE hold time	T_{ehd}	5	-	-	ns	-
Output stable time	T_{sst}	-	-	6	μ s	10% to 90% target voltage. CL=90pF, R=10K ohm (Cascade)
				3		

Table 10.1: TTL mode AC electrical characteristics

7.3 PARALLEL RGB INPUT TIMING TABLE

DE mode (1024x600)

Parameter	Symbol	Spec.			Unit
		Min.	Typ.	Max.	
DCLK Frequency	fclk	40.8	51.2	67.2	MHz
Horizontal Display Area	thd	1024			DCLK
HSD Period	th	1114	1344	1400	DCLK
HSD Blanking	thb+ thfp	90	320	376	DCLK
Vertical Display Area	tvd	600			T_H
VSD Period	tv	610	635	800	T_H
VSD Blanking	tvbp+ tvfp	10	35	200	T_H

7.4 TIMING DIAGRAM

Input Clock and Data Timing Diagram

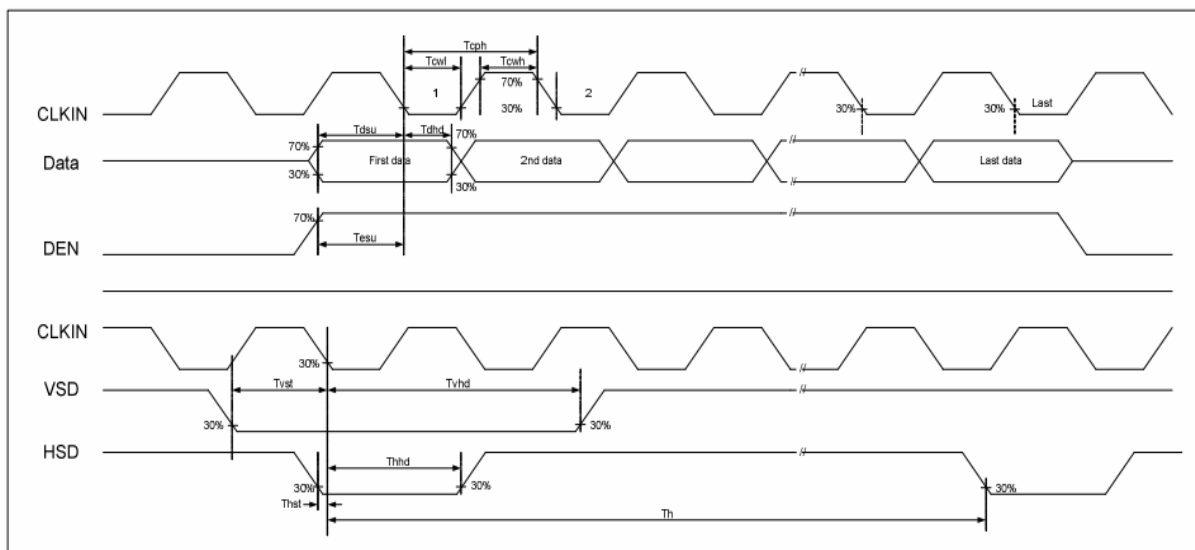

8. Backlight Characteristic

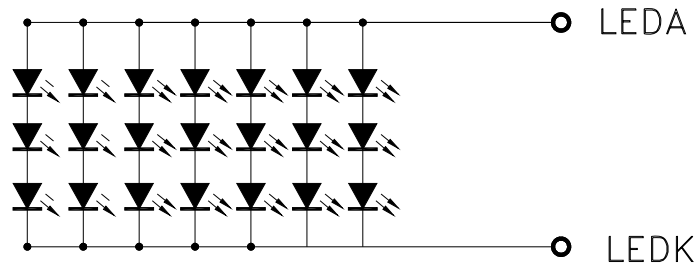

Item	Symbol	MIN	TYP	MAX	UNIT	Test Condition
Supply Voltage	Vf	8.1	9.0	10.2	V	If=180mA
Supply Current	If	-	180	-	mA	-
Luminous Intensity for LCM	-	280	300	-	cd/m ²	If=180mA
Uniformity for LCM	-	80	-	-	%	If=180mA
Life Time	-	20000	-	-	Hr	If=180mA
Backlight Color	White					

9. Optical Characteristics

Item	Conditions	Min.	Typ.	Max.	Unit	Note	
Viewing Angle (CR>10)	Horizontal	θ_L	78	80	-	degree	(1),(2),(6)
		θ_R	78	80	-		
	Vertical	θ_T	78	80	-		
		θ_B	78	80	-		
Contrast Ratio	Center	600	800	-	-	(1),(3),(6)	
Response Time	Rising	-	25	35	ms	(1),(4),(6)	
	Falling						
CF Color Chromaticity (CIE1931)	Red x	Typ. -0.05	0.602	Typ. +0.05	-	(1), (6)	
	Red y		0.328		-		
	Green x		0.301		-		
	Green y		0.556		-		
	Blue x		0.148		-		
	Blue y		0.168		-		
	White x		0.308		-		
	White y		0.342		-		

Note (1) Measurement Setup: The LCD module should be stabilized at given temp. 25°C for 15 minutes to avoid abrupt temperature change during measuring. In order to stabilize the luminance, the measurement should be executed after lighting backlight for 15 minutes in a windless room.

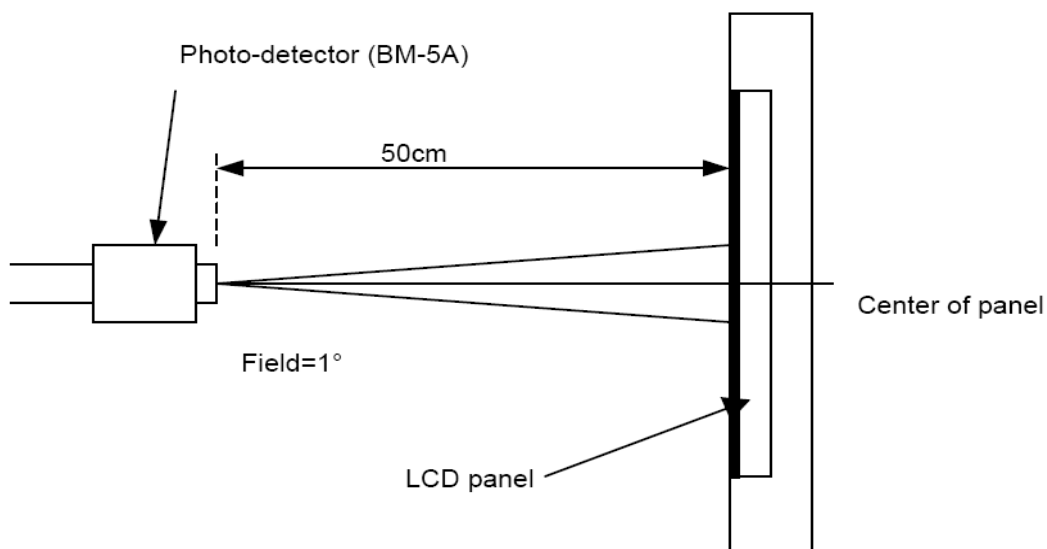

Note (2) Definition of Viewing Angle

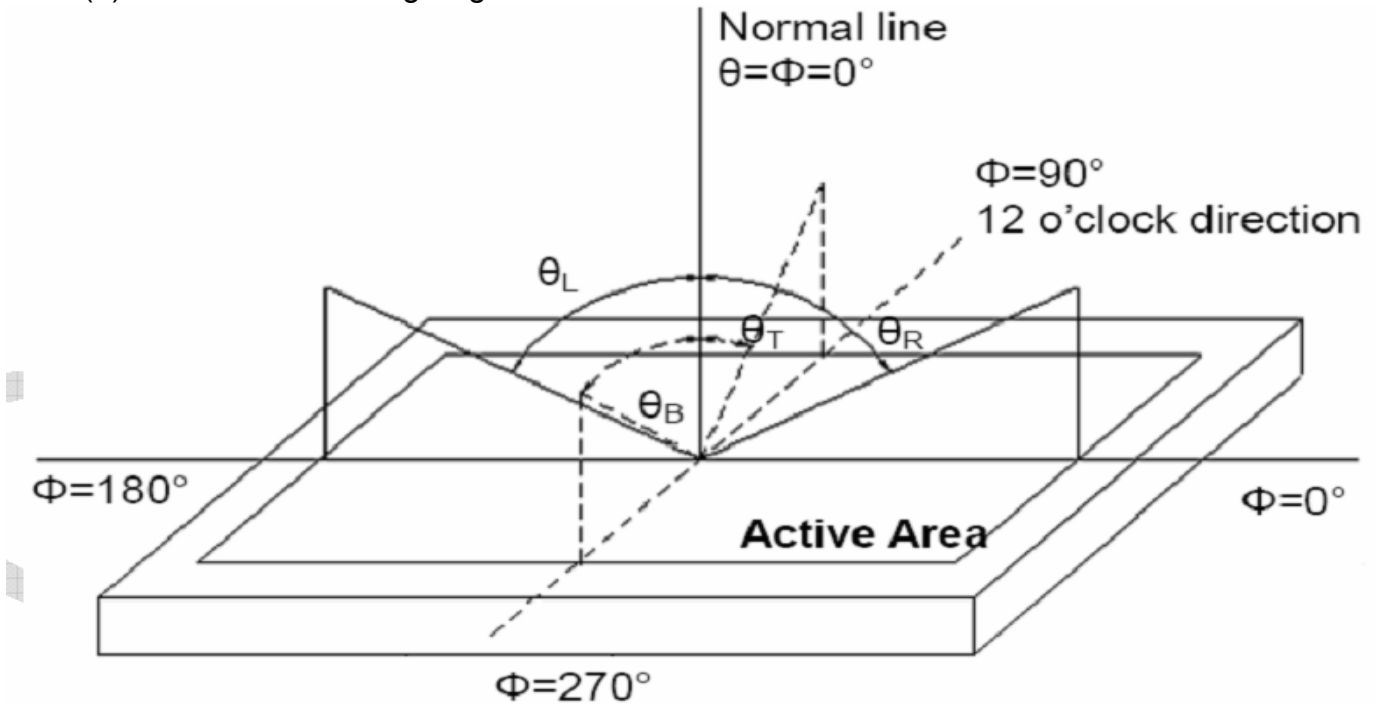

Note (3) Definition of Contrast Ratio (CR)

The contrast ratio can be calculated by the following expression

$$\text{Contrast Ratio (CR)} = L_{63} / L_0$$

L_{63} : Luminance of gray level 63, L_0 : Luminance of gray level 0

Note (4) Definition of response time

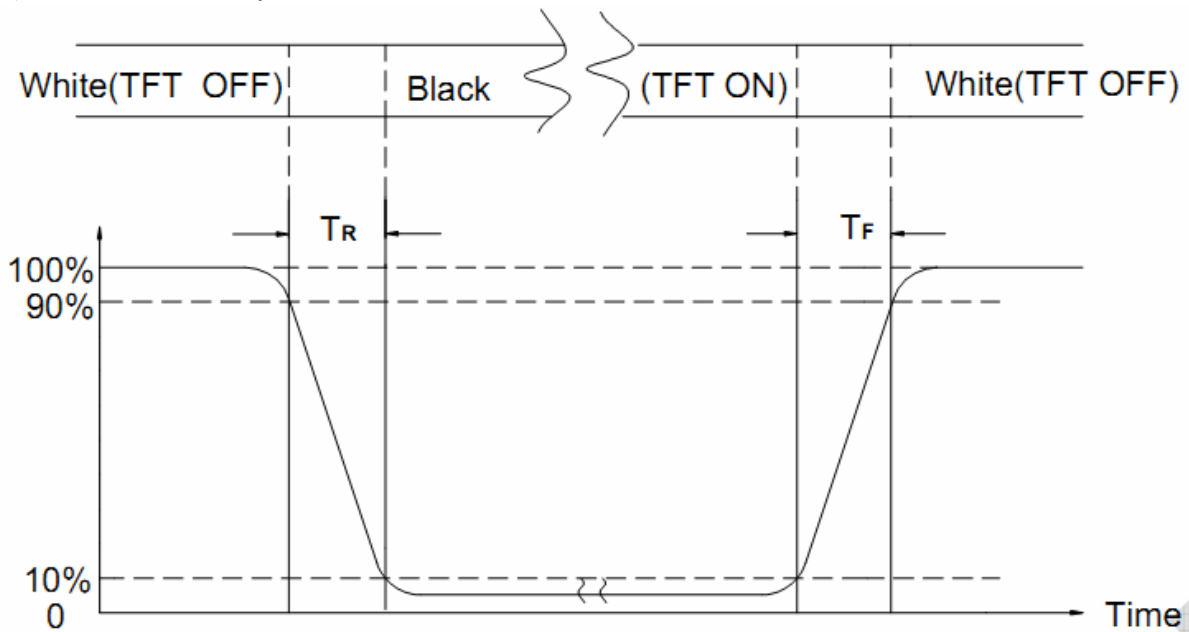

Note (5) Definition of Transmittance (Module is without signal input)

$$\text{Transmittance} = \text{Center Luminance of LCD} / \text{Center Luminance of Back Light} \times 100\%$$

Note (6) Definition of color chromaticity (CIE1931)

Color coordinates measured at the center point of LCD

10. Reliability Test Conditions and Methods

11. Inspection Standard

NO.	TEST ITEMS	TEST CONDITION	INSPECTION AFTER TEST
①	High Temperature Storage	80°C±5°C×96Hours	Inspection after 2~4hours storage at room temperature, the samples should be free from defects: 1, Air bubble in the LCD. 2, Seal leak. 3, Non-display. 4, Missing segments. 5, Glass crack. 6, Current IDD is twice higher than initial value. 7, The surface shall be free from damage. 8, The electric characteristic requirements shall be satisfied.
②	Low Temperature Storage	-30°C±5°C×96Hours	
③	High Temperature Operating	70°C±5°C×96Hours	
④	Low Temperature Operating	-20°C±5°C×96Hours	
⑤	Temperature Cycle(Storage)	-30°C ↔ 25°C ↔ 80°C (30min) ← (5min) → (30min) 1cycle Total 10cycle	
⑥	Damp Proof Test (Storage)	50°C±5°C×90%RH×96Hours	
⑦	Vibration Test	Frequency:10Hz~55Hz~10Hz Amplitude:1.5M X,Y,Z direction for total 3hours (packing condition test will be tested by a carton)	
⑧	Drooping Test	Drop to the ground from 1M height one time every side of carton. (packing condition test will be tested by a carton)	
⑨	ESD Test	Voltage:±8KV,R:330Ω,C:150PF,Air Mode,10times	

REMARK:

- 1, The Test samples should be applied to only one test item.
- 2, Sample side for each test item is 5~10pcs.
- 3,For Damp Proof Test, Pure water(Resistance > 10MΩ)should be used.
- 4,In case of malfunction defect caused by ESD damage, if it would be recovered to normal state after resetting, it would be judge as a good part.
- 5, EL evaluation should be accepted from reliability test with humidity and temperature: Some defects such as black spot/blemish can happen by natural chemical reaction with humidity and Fluorescence EL has.
- 6, Failure Judgment Criterion: Basic Specification Electrical Characteristic, Mechanical Characteristic, Optical Characteristic.

11.1. QUALITY :

THE QUALITY OF GOODS SUPPLIED TO PURCHASER SHALL COME UP TO THE FOLLOWING STANDARD.

11.1.1. INSPECTION TOOLS AND INSTRUMENTS

Vernier calipers, film scales, multimeter, magnifying eyepiece, ND5%, luminance meter and so on.

11.1.2. THE METHOD OF PRESERVING GOODS

AFTER DELIVERY OF GOODS FROM YUXIANG TO PURCHASER. PURCHASER SHALL CONTROL THE LCM AT -10 TO 40 ,AND IT MIGHT BE DESIRABLE TO KEEP AT THE NORMAL ROOM TEMPERATURE AND HUMIDITY UNTIL INCOMING INSPECTION OR THROWING INTO PROCESS LINE.

11.1.3. INCOMING INSPECTION

(A) THE METHOD OF INSPECTION

IF PURCHASER MAKE AN INCOMING INSPECTION , A SAMPLING PLAN SHALL BE APPLIED ON THE CONDITION THAT QUALITY OF ONE DELIVERY SHALL BE REGARDED AS ONE LOT.

(B) THE STANDARD OF QUALITY

ISO-2859-1 (SAME AS MIL-STD-105E) ,LEVEL:II

CLASS	AQL(%)
CRITICAL	0.4 %
MAJOR	0.65 %
MINOR	1.5 %

EVERY ITEM SHALL BE INSPECTED ACCORDING TO THE CLASS.

(C) MEASURE

IF AS THE RESULT OF ABOVE RECEIVING INSPECTION , A LOT OUT IS DISCOVERED. PURCHASER SHALL BE INFORM SELLER OF IT WITHIN SEVEN DAYS. BUT FIRST SHIPMENT WITHIN FOURTEEN DAYS.

11.1.4. WARRANTY POLICY

YUXIANG WILL PROVIDE ONE-YEAR WARRANTY FOR THE PRODUCTS ONLY IF UNDER SPECIFICATION OPERATING CONDITIONS. YUXIANG WILL REPLACE NEW PRODUCTS FOR THESE DEFECT PRODUCTS WHICH UNDER WARRANTY PERIOD AND BELONG TO THE RESPONSIBILITY OF YUXIANG.

11.2. CHECKING CONDITION

11.2.1. CHECKING DIRECTION SHALL BE IN THE 45 DEGREE AREA TO FACE THE SAMPLE.

11.2.2. CHECKER SHALL SEE OVER 300±25 mm. WITH BARE EYES FAR FROM SAMPLE

11.2.3. Ambient Illumination:

0 ~30 Lux for functional inspection

500 ~ 1200 Lux for external appearance inspection.

11.2.4. TEST AREA:

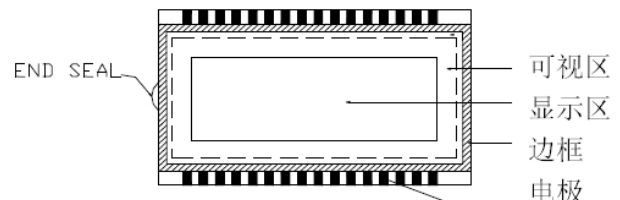
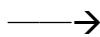

11.2.5. Inspection should be carried out with rope electrostatic ring and static finger cover (both hands except small fingers must be worn)

11.2.6. The inspector may make a visual inspection or a comparative examination with a film ruler and a magnifying eyepiece. Individual defects shall be determined according to the limited samples.

11.2.7. Functional testing uses electrical testing fixtures or test fixtures required by customers.

11.2.8. the ion fan should be used when testing.

11.2.9. the principle of judgment

11.3.1 If the defect outside the visual area does not affect the assembly and display, it will be judged as a good product.

11.3.2 Poor definition

Pixel:

A combination of three sub-pixels (Red + Green + Blue).

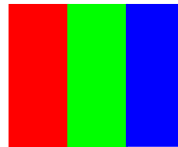

Dot:

Any of the sub-pixels (Red or Green or Blue).



Bright and dark dots:

A point pixel (sub-pixel: R, G, B pixels) is lit or turned off during the display function test.

Highlights:

Usually considered to be shown on a black screen.

Dark spots:

They are generally considered to be shown on R, G, B solid colors or white images.

Neighborhood:

Two or three adjacent point pixels (dot: sub-pixel) connected together (R, G or G, B or B, R or RGB).

11.3. INSPECTION PLAN :

CLASS	ITEM	JUDGEMENT	CLASS
PACKING & INDICATE	1. OUTSIDE AND INSIDE PACKAGE	"MODEL NO." , "LOT NO." AND "QUANTITY" SHOULD INDICATE ON THE PACKAGE.	Minor
	2. MODEL MIXED AND QUANTITY	OTHER MODEL MIXED.....REJECTED QUANTITY SHORT OR OVER.....REJECTED	Critical
	3. PRODUCT INDICATION	"MODEL NO." SHOULD INDICATE ON THE PRODUCT	Major
ASSEMBLY	4. DIMENSION, LCD GLASS SCRATCH AND SCRIBE DEFECT.	ACCORDING TO SPECIFICATION OR DRAWING.	Major
APPEARANCE	5. VIEWING AREA	POLARIZER EDGE OR LCD'S SEALING LINE IS VISABLE IN THE VIEWING AREAREJECTED	Minor
	6. BLEMISH · BLACK SPOT · WHITE SPOT IN THE LCD AND LCD GLASS CRACKS	ACCORDING TO STANDARD OF VISUAL INSPECTION(INSIDE VIEWING AREA)	Minor
	7. BLEMISH · BLACK SPOT WHITE SPOT AND SCRATCH ON THE POLARIZER	ACCORDING TO STANDARD OF VISUAL INSPECTION(INSIDE VIEWING AREA)	Minor
	8. BUBBLE IN POLARIZER	ACCORDING TO STANDARD OF VISUAL INSPECTION(INSIDE VIEWING AREA)	Minor
	9. LCD'S RAINBOW COLOR	STRONG DEVIATION COLOR (OR NEWTON RING) OF LCD.....REJECTED. OR ACCORDING TO LIMITED SAMPLE (IF NEEDED, AND INSIDE VIEWING AREA)	Minor
ELECTRICAL	10. ELECTRICAL AND OPTICAL CHARACTERISTICS (CONTRAST· VOP · CHROMATICITY ... ETC)	ACCORDING TO SPECIFICATION OR DRAWING . (INSIDE VIEWING AREA)	Critical
	11.MISSING LINE	MISSING DOT· LINE · CHARACTERREJECTED	Critical
	12.SHORT CIRCUIT· WRONG PATTERN DISPLAY	NO DISPLAY · WRONG PATTERN DISPLAY · CURRENT CONSUMPTION OUT OF SPECIFICATION..... REJECTED	Critical
	13. DOT DEFECT (FOR COLOR AND TFT)	ACCORDING TO STANDARD OF VISUAL INSPECTION	Minor

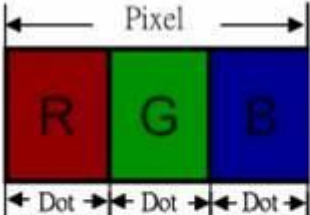
NO.	CLASS	ITEM	JUDGEMENT																				
11.4.1	MINOR	BLACK AND WHITE SPOT FOREIGN MATERIEL DUST IN THE CELL BLEMISH SCRATCH	<p>(A) ROUND TYPE: unit : mm.</p> <table border="1"> <thead> <tr> <th>DIAMETER (mm.)</th> <th>ACCEPTABLE Q'TY</th> </tr> </thead> <tbody> <tr> <td>$\Phi \leq 0.15$</td> <td>Distance\geq1mm</td> </tr> <tr> <td>$0.15 < \Phi \leq 0.4$</td> <td>3 (Distance\geq15mm)</td> </tr> <tr> <td>$0.4 < \Phi$</td> <td>0</td> </tr> </tbody> </table> <p>NOTE: $\Phi=(\text{LENGTH}+\text{WIDTH})/2$</p> <p>(B) LINEAR TYPE: unit : mm.</p> <table border="1"> <thead> <tr> <th>LENGTH</th> <th>WIDTH</th> <th>ACCEPTABLE Q'TY</th> </tr> </thead> <tbody> <tr> <td>-----</td> <td>$W \leq 0.03$</td> <td>Distance\geq1mm</td> </tr> <tr> <td>$L \leq 4.0$</td> <td>$0.03 < W \leq 0.05$</td> <td>3 (Distance\geq15mm)</td> </tr> <tr> <td>-----</td> <td>$0.05 < W$</td> <td>FOLLOW ROUND TYPE</td> </tr> </tbody> </table>	DIAMETER (mm.)	ACCEPTABLE Q'TY	$\Phi \leq 0.15$	Distance \geq 1mm	$0.15 < \Phi \leq 0.4$	3 (Distance \geq 15mm)	$0.4 < \Phi$	0	LENGTH	WIDTH	ACCEPTABLE Q'TY	-----	$W \leq 0.03$	Distance \geq 1mm	$L \leq 4.0$	$0.03 < W \leq 0.05$	3 (Distance \geq 15mm)	-----	$0.05 < W$	FOLLOW ROUND TYPE
DIAMETER (mm.)	ACCEPTABLE Q'TY																						
$\Phi \leq 0.15$	Distance \geq 1mm																						
$0.15 < \Phi \leq 0.4$	3 (Distance \geq 15mm)																						
$0.4 < \Phi$	0																						
LENGTH	WIDTH	ACCEPTABLE Q'TY																					
-----	$W \leq 0.03$	Distance \geq 1mm																					
$L \leq 4.0$	$0.03 < W \leq 0.05$	3 (Distance \geq 15mm)																					
-----	$0.05 < W$	FOLLOW ROUND TYPE																					
11.4.2	MINOR	BUBBLE IN POLARIZER DENT ON POLARIZER	<p style="text-align: right;">unit : mm.</p> <table border="1"> <thead> <tr> <th>DIAMETER</th> <th>ACCEPTABLE Q'TY</th> </tr> </thead> <tbody> <tr> <td>$\Phi \leq 0.2$</td> <td>Distance\geq1mm</td> </tr> <tr> <td>$0.2 < \Phi \leq 0.5$</td> <td>3 (Distance\geq15mm)</td> </tr> <tr> <td>$0.5 < \Phi$</td> <td>0</td> </tr> </tbody> </table>	DIAMETER	ACCEPTABLE Q'TY	$\Phi \leq 0.2$	Distance \geq 1mm	$0.2 < \Phi \leq 0.5$	3 (Distance \geq 15mm)	$0.5 < \Phi$	0												
DIAMETER	ACCEPTABLE Q'TY																						
$\Phi \leq 0.2$	Distance \geq 1mm																						
$0.2 < \Phi \leq 0.5$	3 (Distance \geq 15mm)																						
$0.5 < \Phi$	0																						
11.4.3	MINOR	Dot Defect	<table border="1"> <thead> <tr> <th>Items</th> <th>ACC. Q'TY</th> </tr> </thead> <tbody> <tr> <td>Bright dot</td> <td>$N \leq 2$ (Distance\geq15mm)</td> </tr> <tr> <td>Dark dot</td> <td>$N \leq 3$ (Distance\geq15mm)</td> </tr> </tbody> </table> <p>Pixel Define :</p>  <p>Note 1: The definition of dot: The size of a defective dot over 1/2 of whole dot is regarded as one defective dot. Definition: $<1/2\text{dot}$ and visible by 5% ND filter $N \leq 5$</p> <p>Note 2: Bright dot: Dots appear bright and unchanged in size in which LCD panel is displaying under black pattern.</p> <p>Note 3: Dark dot: Dots appear dark and unchanged in size in which LCD panel is displaying under pure red, green, blue pattern.</p>	Items	ACC. Q'TY	Bright dot	$N \leq 2$ (Distance \geq 15mm)	Dark dot	$N \leq 3$ (Distance \geq 15mm)														
Items	ACC. Q'TY																						
Bright dot	$N \leq 2$ (Distance \geq 15mm)																						
Dark dot	$N \leq 3$ (Distance \geq 15mm)																						
11.4.4	MINOR	Mura	Not visible through 5% ND filter in 50% gray or judge by limit sample if necessary																				

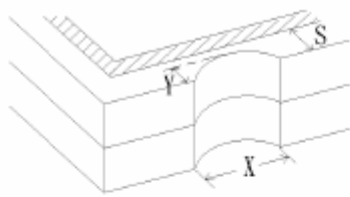
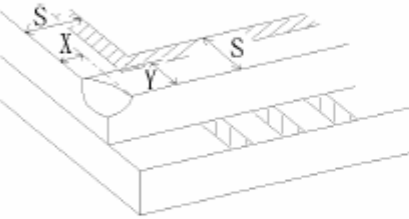
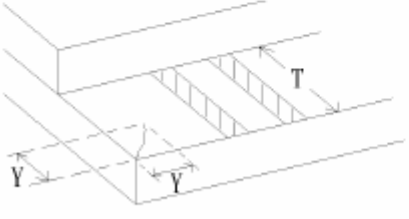
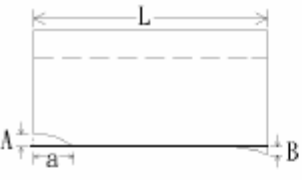
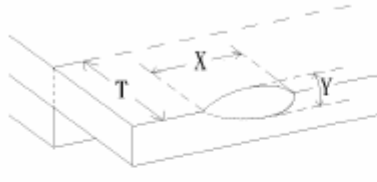
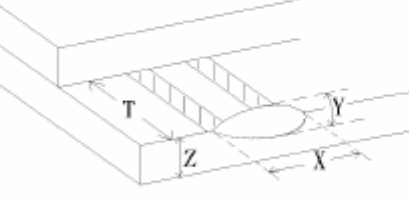
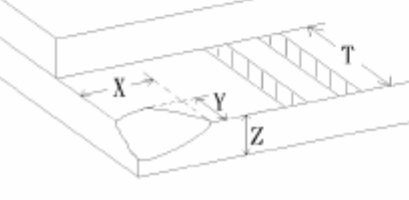
NO.	CLASS	ITEM	JUDGEMENT
11.4.4	MINOR	LCD GLASS CHIPPING	 $Y > S$ Reject
11.4.5	MINOR	LCD GLASS CHIPPING	 $X \text{ or } Y > S$ Reject
11.4.6	MAJOR	LCD GLASS GLASS CRACK	 $Y > (1/2) T$ Reject
11.4.7	MAJOR	LCD GLASS SCRIBE DEFECT	 <ol style="list-style-type: none"> $a > L/3$, $A > 1.5\text{mm}$. Reject B : ACCORDING TO DIMENSION
11.4.8	MINOR	LCD GLASS CHIPPING (ON THE TERMINAL AREA)	 $\Phi = (x+y)/2 > 2.5 \text{ mm}$ Reject
11.4.9	MINOR	LCD GLASS CHIPPING (ON THE TERMINAL SURFACE)	 $Y > (1/3) T$ Reject
11.4.10	MINOR	LCD GLASS CHIPPING	 $Y > T$ Reject

12. Handling Precautions

12.1 Mounting method

The LCD panel of YHW TFT LCD module consists of two thin glass plates with polarizers which easily be damaged. And since the module is so constructed as to be fixed by utilizing fitting holes in the printed circuit board.

Extreme care should be needed when handling the LCD modules.

12.2 Caution of LCD handling and cleaning

When cleaning the display surface, Use soft cloth with solvent

[Recommended below] and wipe lightly

- Isopropyl alcohol
- Ethyl alcohol

Do not wipe the display surface with dry or hard materials that will damage the polarizer surface.

Do not use the following solvent:

- Water
- Aromatics

Do not wipe ITO pad area with the dry or hard materials that will damage the ITO patterns

Do not use the following solvent on the pad or prevent it from being contaminated:

- Soldering flux
- Chlorine (Cl) , Sulfur (S)

If goods were sent without being silicon coated on the pad, ITO patterns could be damaged due to the corrosion as time goes on.

If ITO corrosion happens by miss-handling or using some materials such as Chlorine (Cl), Sulfur (S) from customer, Responsibility is on customer.

12.3 Caution against static charge

The LCD module uses C-MOS LSI drivers, so we recommend that you:

Connect any unused input terminal to POWER or GROUND, do not input any signals before power is turned on, and ground your body, work/assembly areas, and assembly equipment to protect against static electricity.

12.4 packing

- Module employs LCD elements and must be treated as such.
- Avoid intense shock and falls from a height.
- To prevent modules from degradation, do not operate or store them exposed direct to sunshine or high temperature/humidity

12.5 Caution for operation

- It is an indispensable condition to drive LCD's within the specified voltage limit since the higher voltage than the limit causes the shorter LCD life.
- An electrochemical reaction due to direct current causes LCD's undesirable deterioration, so that the use of direct current drive should be avoided.
- Response time will be extremely delayed at lower temperature than the operating temperature range and on the other hand at higher temperature LCD's show dark color in them. However those phenomena do not mean malfunction or out of order with LCD's, which will come back in the specified operation temperature.
- If the display area is pushed hard during operation, some font will be abnormally displayed but it resumes normal condition after turning off once.
- Slight dew depositing on terminals is a cause for electro-chemical reaction resulting in terminal open circuit.

Usage under the maximum operating temperature, 50%Rh or less is required.

12.6 storing

In the case of storing for a long period of time for instance, for years for the purpose or replacement use, the following ways are recommended.

- Storage in a polyethylene bag with the opening sealed so as not to enter fresh air outside in it. And with no desiccant.
- Placing in a dark place where neither exposure to direct sunlight nor light's keeping the storage temperature range.
- Storing with no touch on polarizer surface by the anything else.
[It is recommended to store them as they have been contained in the inner container at the time of delivery from us

12.7 Safety

- It is recommendable to crash damaged or unnecessary LCD's into pieces and wash off liquid crystal by either of solvents such as acetone and ethanol, which should be burned up later.
- When any liquid leaked out of a damaged glass cell comes in contact with your hands, please wash it off well with soap and water

13. Precaution for Use

13.1

A limit sample should be provided by the both parties on an occasion when the both parties agreed its necessity. Judgment by a limit sample shall take effect after the limit sample has been established and confirmed by the both parties.

13.2

On the following occasions, the handing of problem should be decided through discussion and agreement between responsible of the both parties.

- When a question is arisen in this specification
- When a new problem is arisen which is not specified in this specifications
- When an inspection specifications change or operating condition change in customer is reported to YUXIANG TFT , and some problem is arisen in this specification due to the change
- When a new problem is arisen at the customer's operating set for sample evaluation in the customer site.

14. Packing Method

TBD