

SPECIFICATION FOR LCD MODULE

Customer : _____

Product Model: YH070NA-23A V03

Sample code: _____

Designed by	Checked by	Approved by

Final Approval by Customer

<input type="checkbox"/> LCM Machinery OK Checked By _____ <input type="checkbox"/> LCM Display OK Checked By _____	<input type="checkbox"/> LCM OK <input type="checkbox"/> NG , Problem survey: Approved By _____
--------------------------------------------------------------------------------------------------------------------------------------------------------	-----------------------------------------------------------------------------------------------------------------------------

※The specification of "TBD" should refer to the measured value of sample . If there is difference between the design specification and measured value, we naturally shall negotiate and agree to solution with customer.

Record of Revision

Version	Revise Date	Page	Content
Pre-Spec.V01	2022/04/15	All	Initial Release.
Pre-Spec.V02	2023/11/05		

Contents

1. General Specifications	1
2. Pin Assignment	2
3. Operation Specifications	5
3.1. Absolute Maximum Ratings	5
3.1.1. Typical Operation Conditions	6
3.1.2. Current Consumption	7
3.1.3. Backlight Driving Conditions	7
3.2. Power Sequence	8
3.3. Timing Characteristics	10
3.3.1. AC Electrical Characteristics	10
3.3.2. Input Clock and Data Timing Diagram	10
3.3.3. DC Electrical Characteristics	11
3.3.4. Timing	12
3.3.5. Data Input Format	13
4. Optical Specifications	14
5. Reliability Test Items	18
6. General Precautions	19
6.1. Safety	19
6.2. Handling	19
6.3. Static Electricity	19
6.4. Storage	19
6.5. Cleaning	19
7. Mechanical Drawing	20
8. Package Drawing	21

1. General Specifications

The specification YH070NA-23A is a 7 "(1024x600) TFT Liquid Crystal Display module with LED Backlight unit , 40 pin LVDS interface, normally white transmissive display mode. This module will be applied to Consumer Electronics(CE Application)

No.	Item	Specification	Remark
1	LCD size	7.0 inch(Diagonal)	
2	Driver element	a-Si TFT active matrix	
3	Resolution	1024 × 3(RGB) × 600	
4	Display mode	Normally White, Transmissive	
5	Pixel size	0.1506(W) × 0.1432(H) mm	
6	Active area	154.2144(W) × 85.92(H) mm	
7	Module size	164.9(W) × 100(H) × 4.8(D) mm	Note 1
8	Surface treatment	Hard Coating	
9	Color arrangement	RGB-stripe	
10	Interface	LVDS	
11	View direction(Gray Inversion)	6 O'Clock	
12	Backlight power consumption	2.62 W (Typ.)	
13	Panel power consumption	0.4 W (Typ.) , 0.6 W(Max.)	
14	Weight	135g (Typ.)	
15	Source Driver IC	EK79001/HX8282-A	
16	Gate Driver IC	EK73215 /HX8696-A	
17	Driving methods	1+2 dot	

Note 1: Refer to Mechanical Drawing.

2. Pin Assignment

FPC Connector is used for the module electronics interface. The recommended model is FH12A-40S-0.5SH manufactured by Hirose.

Pin No.	Symbol	I/O	Function	Remark
1	VCOM	P	Common Voltage	
2	VDD	P	Power Voltage for digital circuit	
3	VDD	P	Power Voltage for digital circuit	
4	NC	---	No connection	
5	Reset	I	Global reset pin	
6	STBYB	I	Standby mode, Normally pulled high STBYB = "1", normal operation STBYB = "0", timing controller, source driver will turn off, all output are High-Z	
7	GND	P	Ground	
8	RXIN0-	I	- LVDS differential data input	
9	RXIN0+	I	+ LVDS differential data input	
10	GND	P	Ground	
11	RXIN1-	I	- LVDS differential data input	
12	RXIN1+	I	+ LVDS differential data input	
13	GND	P	Ground	
14	RXIN2-	I	- LVDS differential data input	
15	RXIN2+	I	+ LVDS differential data input	
16	GND	P	Ground	
17	RXCLKIN-	I	- LVDS differential clock input	
18	RXCLKIN+	I	+ LVDS differential clock input	
19	GND	P	Ground	
20	RXIN3-	I	- LVDS differential data input	
21	RXIN3+	I	+ LVDS differential data input	

22	GND	P	Ground	
23	NC	---	No connection	
24	NC	---	No connection	
25	GND	P	Ground	
26	NC	---	No connection	
27	NC	---	No connection	
28	SELB	I	6bit/8bit mode select	Note1
29	AVDD	P	Power for Analog Circuit	
30	GND	P	Ground	
31	LED-	P	LED Cathode	
32	LED-	P	LED Cathode	
33	L/R	I	Horizontal inversion	Note2
34	U/D	I	Vertical inversion	Note2
35	VGL	P	Gate OFF Voltage	
36	NC	---	No connection	
37	NC	---	No connection	
38	VGH	P	Gate ON Voltage	
39	LED+	P	LED Anode	
40	LED+	P	LED Anode	

I: input, O: output, P: Power

Note1: If LVDS input data is 6 bits ,SELB must be set to High;
If LVDS input data is 8 bits ,SELB must be set to Low.

Note2: When L/R="0", set right to left scan direction.
When L/R="1", set left to right scan direction.
When U/D="0", set top to bottom scan direction.
When U/D="1", set bottom to top scan direction.

Note: Definition of scanning direction.
Refer to the figure as below:

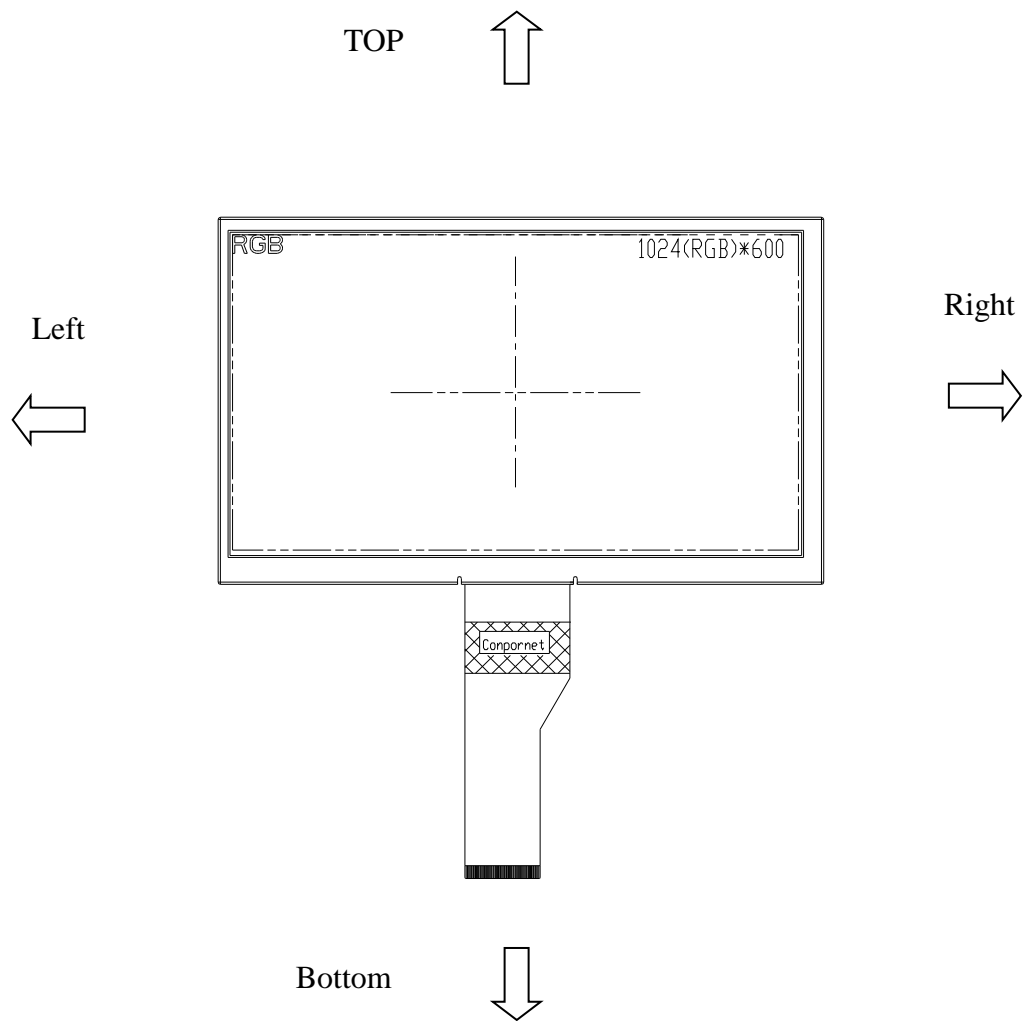

3. Operation Specifications

3.1. Absolute Maximum Ratings

(Note 1)

Item	Symbol	Values		Unit	Remark
		Min.	Max.		
Power voltage	DV _{DD}	-0.3	5.0	V	
	AV _{DD}	-0.3	15	V	
	V _{GH}	-0.3	42.0	V	
	V _{GL}	-20.0	0.3	V	
	V _{GH} -V _{GL}	-0.3	40.0	V	
Operation Temperature	T _{OP}	-20	70	°C	
Storage Temperature	T _{ST}	-30	80	°C	
LED Reverse Voltage	V _R	-	5	V	Each LED
LED Forward Current	I _F	-	60	mA	Each LED

Note 1: The absolute maximum rating values of this product are not allowed to be exceeded at any times. Should a module be used with any of the absolute maximum ratings exceeded, the characteristics of the module may not be recovered, or in an extreme case, the module may be permanently destroyed.

3.1.1. Typical Operation Conditions

(Note 1)

Item	Symbol	Values			Unit	Remark
		Min.	Typ.	Max.		
Power voltage	DV _{DD}	3.0	3.3	3.6	V	Note 2
	AV _{DD}	11.9	12	12.1	V	
	V _{GH}	14.5	15	15.5	V	
	V _{GL}	-10.5	-10	-9.5	V	
Input signal voltage	V _{COM}	4.05	4.55	5.05	V	Note 4
Input logic high voltage	V _{IH}	0.7 DV _{DD}	-	DV _{DD}	V	Note 3
Input logic low voltage	V _{IL}	0	-	0.3 DV _{DD}	V	

Note 1: Be sure to apply DV_{DD} and V_{GL} to the LCD first, and then apply V_{GH}.

Note 2: DV_{DD} setting should match the signals output voltage (refer to Note 3) of customer's system board.

Note 3: LVDS, Reset, STBYB, SELB,L/R,U/D

Note 4: Typ. V_{COM} is only a reference value, it must be optimized according to each LCM. Be sure to use VR.

Note5: The power voltage ripple of AV_{DD} & V_{COM} is +/-50mV, others power voltage ripple such as DV_{DD},V_{GH} & V_{GL} is +/-100mV.

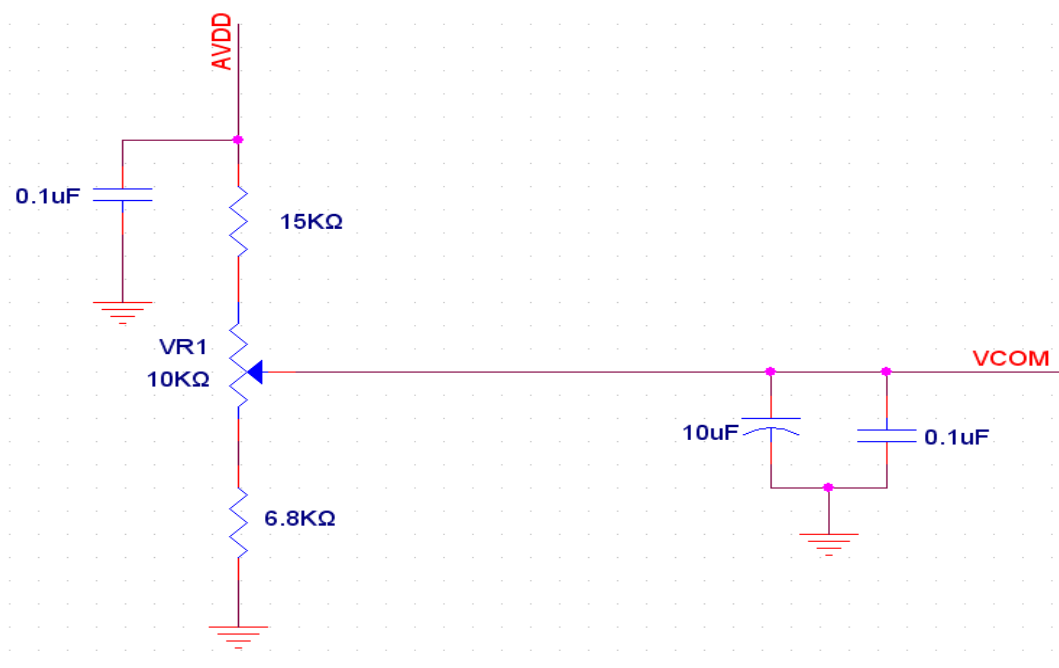

3.1.2. Current Consumption

Item	Symbol	Values			Unit	Remark
		Min.	Typ.	Max.		
Current for Driver	$I_{V_{GH}}$	0.1	0.4	0.8	mA	$V_{GH} = 15V$
	$I_{V_{GL}}$	0.2	0.8	1.2	mA	$V_{GL} = -10V$
	$I_{D_{V_{DD}}}$	16	35	55	mA	$D_{V_{DD}} = 3.3V$
	$I_{A_{V_{DD}}}$	4	20	32	mA	$A_{V_{DD}} = 12V$

Note: test pattern: Black pattern.

3.1.3. Backlight Driving Conditions

Item	Symbol	Values			Unit	Remark
		Min.	Typ.	Max.		
Voltage for LED backlight	V_L	8.4	8.8	10.2	V	Note 1
Current for LED backlight	I_L	--	385	--	mA	
LED life time	-	20,000	-	-	Hr	Note 2

Note 1: The LED Supply Voltage is defined by the number of LED at $T_a = 25^\circ C$ and $I_L = 270mA$.

Note 2: The "LED life time" is defined as the module brightness decrease to 50% original brightness at $T_a = 25^\circ C$ and $I_L = 270mA$. The LED lifetime could be decreased if operating I_L is larger than 270mA.

3.2. Power Sequence

a. Power on:

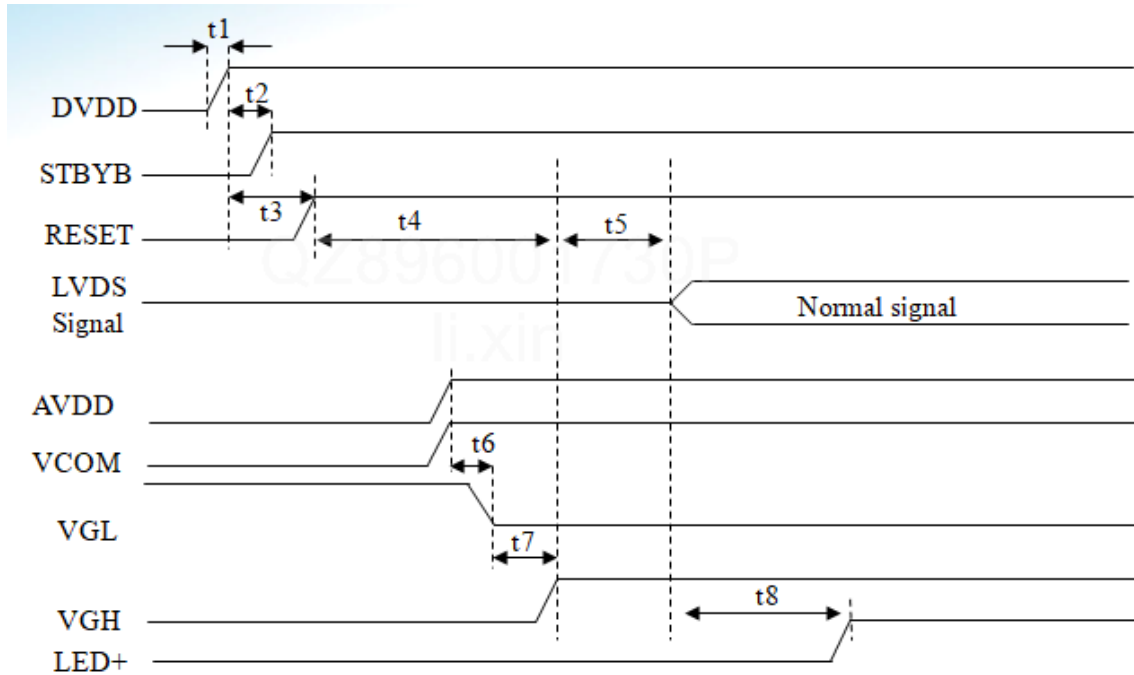

DVDD → RESET → DATA → AVDD Gamma → VGL → VGH → LED+

Symbol	SPEC			Unit
	Min.	Typ.	Max.	
t1	0.5	5	20	ms
t2	20	30	50	ms
t3	1	10(RC Delay)	12	ms
t4	90	-	150	ms
t5	30	-	50	ms
t6	20	-	75	ms
t7	20	-	75	ms
t8	150	-	-	ms

b. Power off:

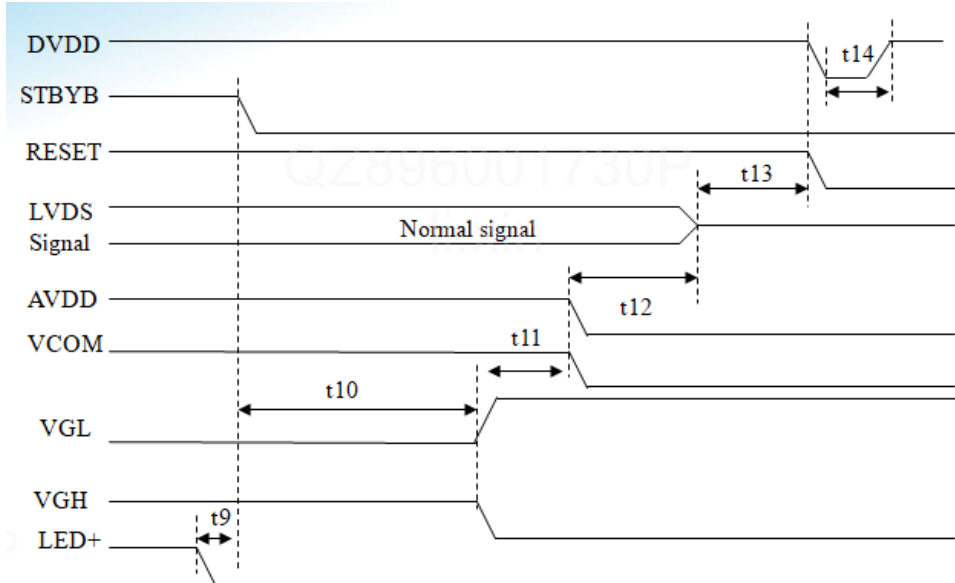

LED+ → VGL\VGH → AVDD Gamma → DATA → RESET → DVDD

Symbol	SPEC			Unit
	Min.	Typ.	Max.	
t9	0.1	1	10	ms
t10	120	150	200	ms
t11	50	100	200	ms
t12	1	10	20	ms
t13	0.1	10	100	ms
t14	500	-	-	ms

3.3. Timing Characteristics

3.3.1. AC Electrical Characteristics

Parameter	Symbol	Values			Unit	Remark
		Min.	Typ.	Max.		
Clock frequency	R_{XFCLK}	40.8	51.2	67.2	MHz	
Input data skew margin	T_{RSKM}	500	900	1200	ps	
Clock high time	T_{LVCH}	$3.8/(7 * R_{XFCLK})$	$4/(7 * R_{XFCLK})$	$4.2/(7 * R_{XFCLK})$	ns	
Clock low time	T_{LVCL}	$2.8/(7 * R_{XFCLK})$	$3/(7 * R_{XFCLK})$	$3.2/(7 * R_{XFCLK})$	ns	

3.3.2. Input Clock and Data Timing Diagram

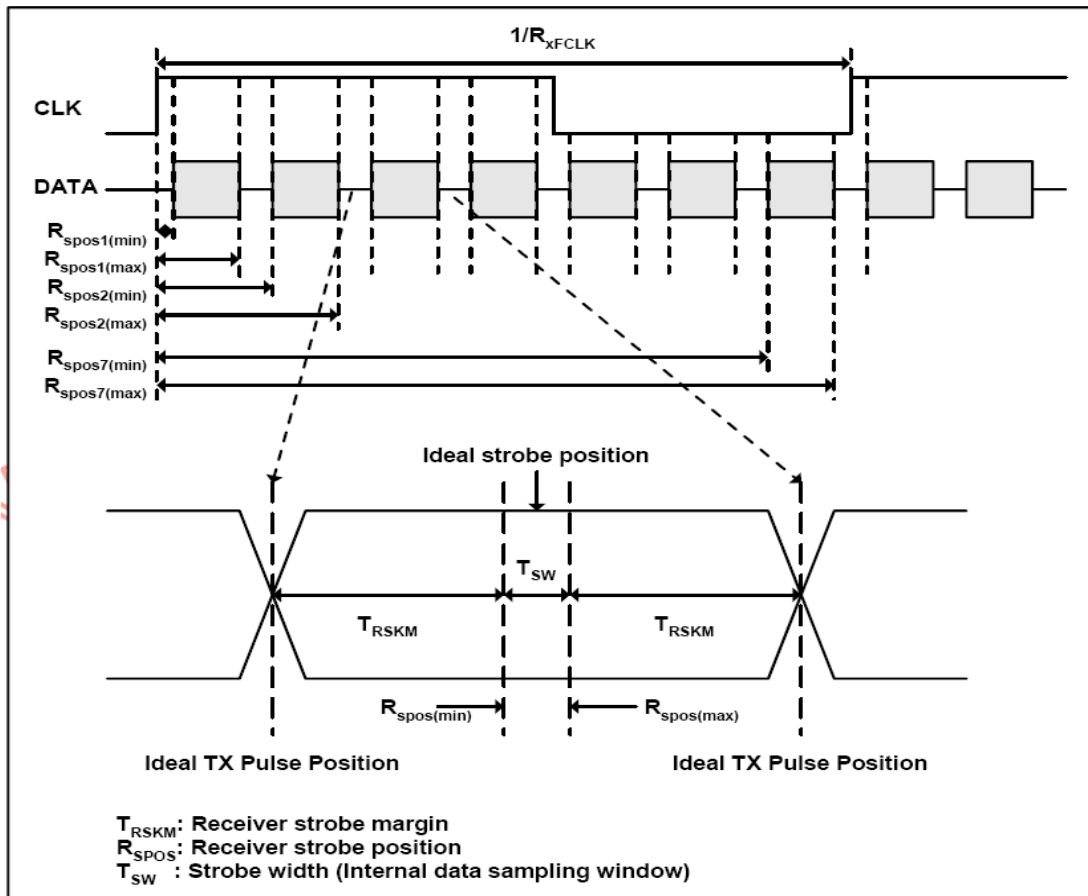
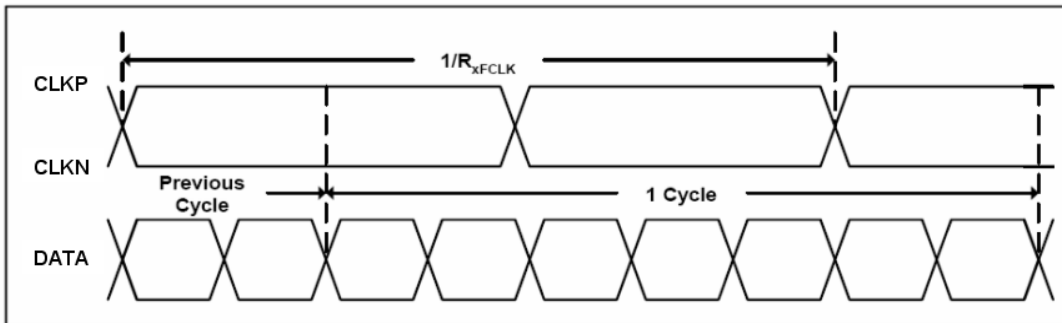

3.3.3. DC Electrical Characteristics

Parameter	Symbol	Values			Unit	Remark
		Min.	Typ.	Max.		
Differential input high Threshold voltage	R_{xVTH}	-	-	0.1	V	$R_{xVCM}=1.2V$
Differential input low Threshold voltage	R_{xVTL}	-0.1	-	-	V	
Input voltage range (singled-end)	R_{xVIN}	0	-	2.4	V	
Differential input common mode voltage	R_{xVCM}	$ V_{ID} /2$	-	$2.4- V_{ID} /2$	V	
Differential voltage	$ V_{ID} $	0.2	-	0.6	V	
Differential input leakage current	$R_{V_{xIz}}$	-10	-	+10	μA	

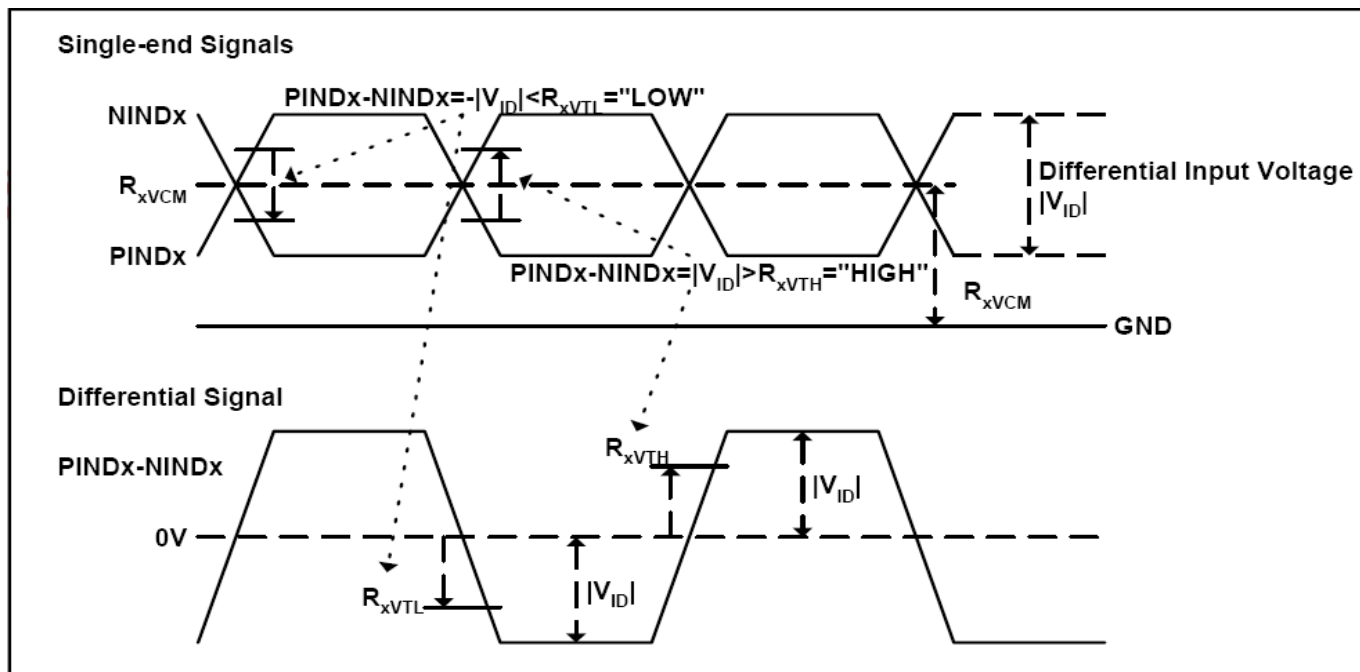

3.3.4. Timing

Item	Symbol	Values			Unit	Remark
		Min.	Typ.	Max.		
Clock Frequency	fclk	40.8	51.2	67.2	MHz	Frame rate =60Hz
Horizontal display area	thd	1024			DCLK	
HS period time	th	1114	1344	1400	DCLK	
HS Blanking	thb	90	320	376	DCLK	
Vertical display area	tvd	600			H	
VS period time	tv	610	635	800	H	
VS Blanking	thb	10	35	200	H	

3.3.5. Data Input Format

6bit LVDS input

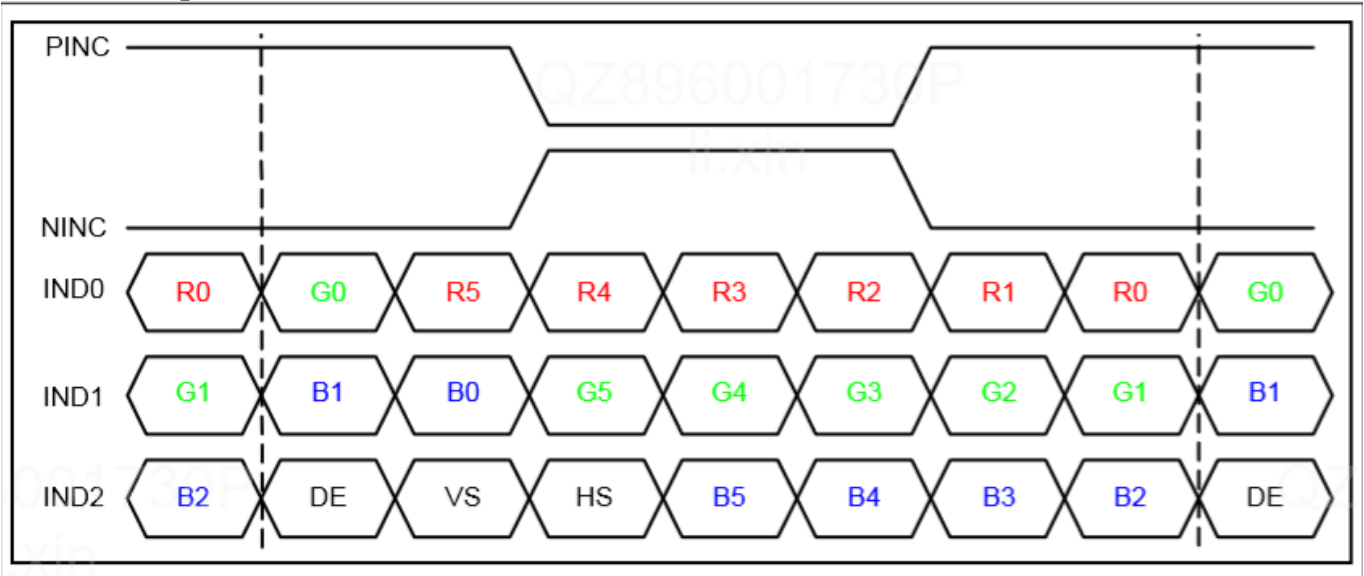

8bit LVDS input

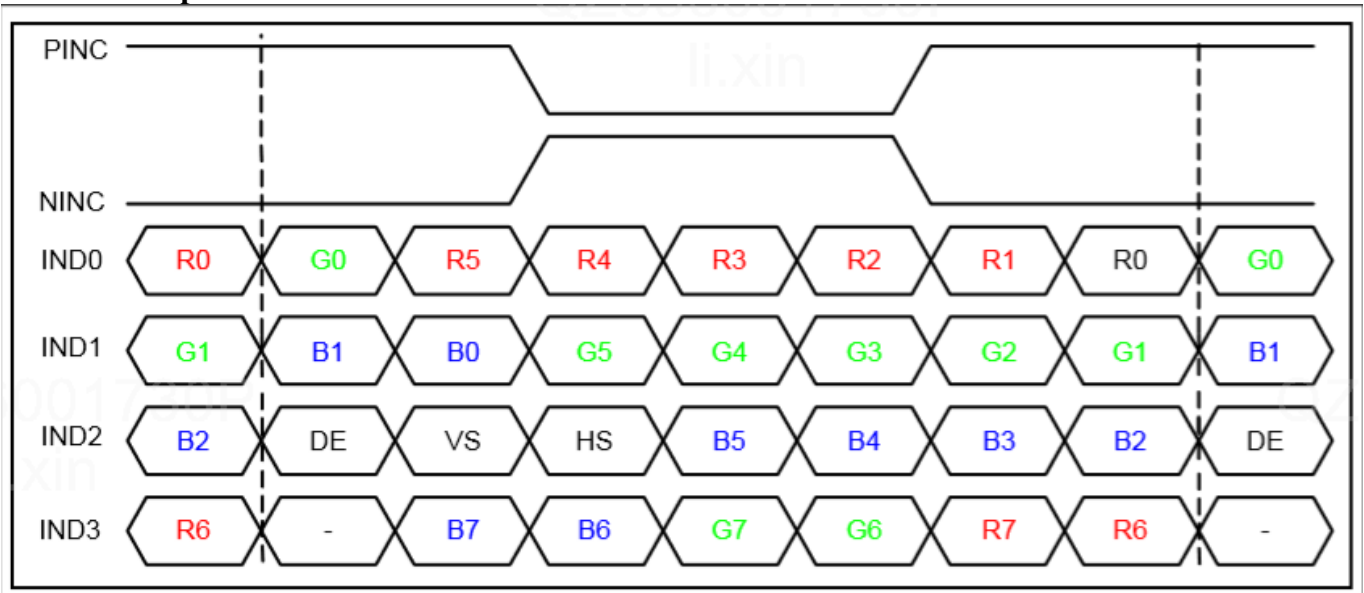

Note: Support DE timing mode only, SYNC mode not supported.

4. Optical Specifications

Item	Symbol	Condition	Values			Unit	Remark
			Min.	Typ.	Max.		
Viewing angle (CR ≥ 10)	θ_L	$\Phi=180^\circ$ (9 o'clock)	75	80	-	degree	Note 1
	θ_R	$\Phi=0^\circ$ (3 o'clock)	75	80	-		
	θ_T	$\Phi=90^\circ$ (12 o'clock)	55	60	-		
	θ_B	$\Phi=270^\circ$ (6 o'clock)	65	70	-		
Response time	T_{ON}	Normal $\theta=\Phi=0^\circ$	-	10	20	msec	Note 3
	T_{OFF}		-	15	30	msec	Note 3
Contrast ratio	CR		500	800	-	-	Note 4
Color chromaticity	W_X		0.26	0.31	0.36	-	Note 2 Note 5 Note 6
	W_Y		0.28	0.33	0.38	-	
Luminance	L		600	700	-	cd/m ²	Note 6
Luminance uniformity	Y_U		70	75	-	%	Note 7

Test Conditions:

1. $DV_{DD}=3.1V$, $I_L=270mA$ (Backlight current), the ambient temperature is $25^\circ C$.
2. The test systems refer to Note 2.

Note 1: Definition of viewing angle range

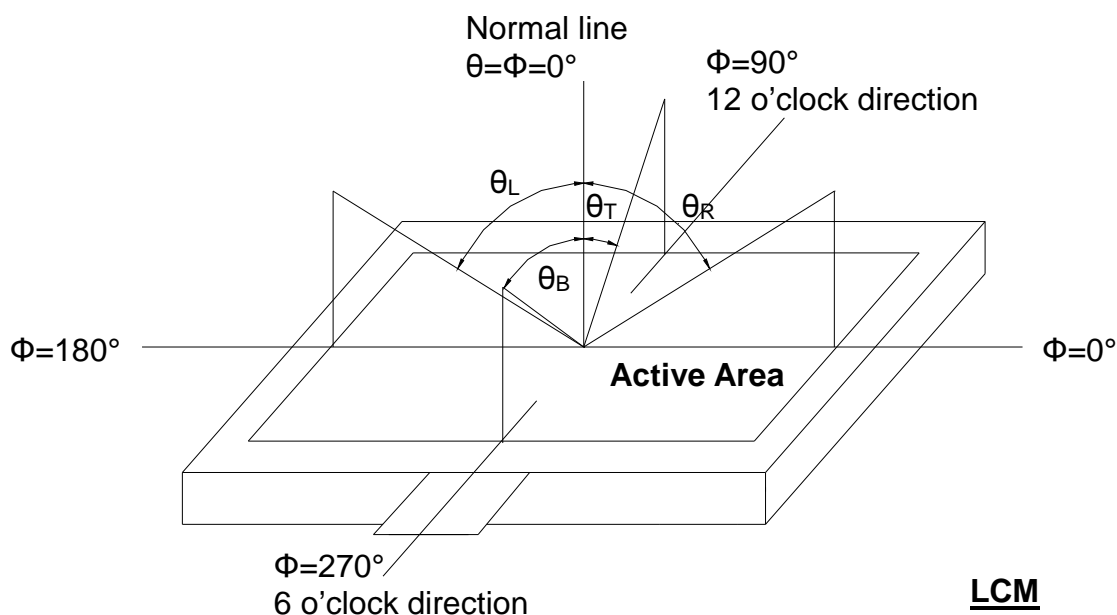

Fig. 4-1 Definition of viewing angle

Note 2: Definition of optical measurement system.

The optical characteristics should be measured in dark room. After 30 minutes operation, the optical properties are measured at the center point of the LCD screen. (Response time is measured by Photo detector TOPCON BM-7, other items are measured by BM-5A/Field of view: 1°/Height: 500mm.)

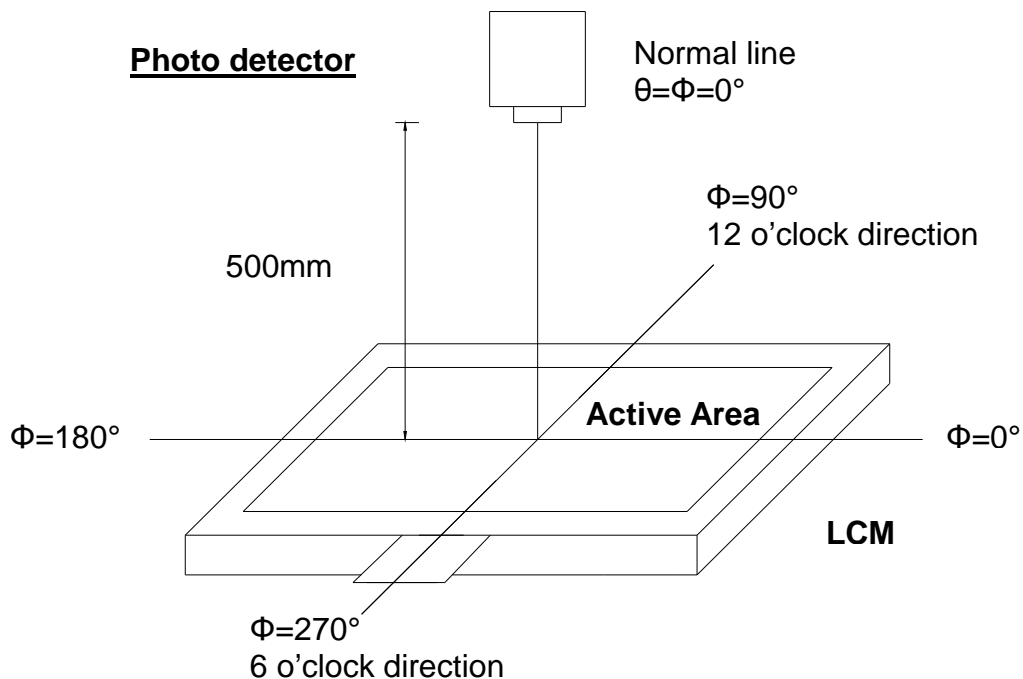

Fig. 4-2 Optical measurement system setup

Note 3: Definition of Response time

The response time is defined as the LCD optical switching time interval between "White" state and "Black" state. Rise time (T_{ON}) is the time between photo detector output intensity changed from 90% to 10%. And fall time (T_{OFF}) is the time between photo detector output intensity changed from 10% to 90%.

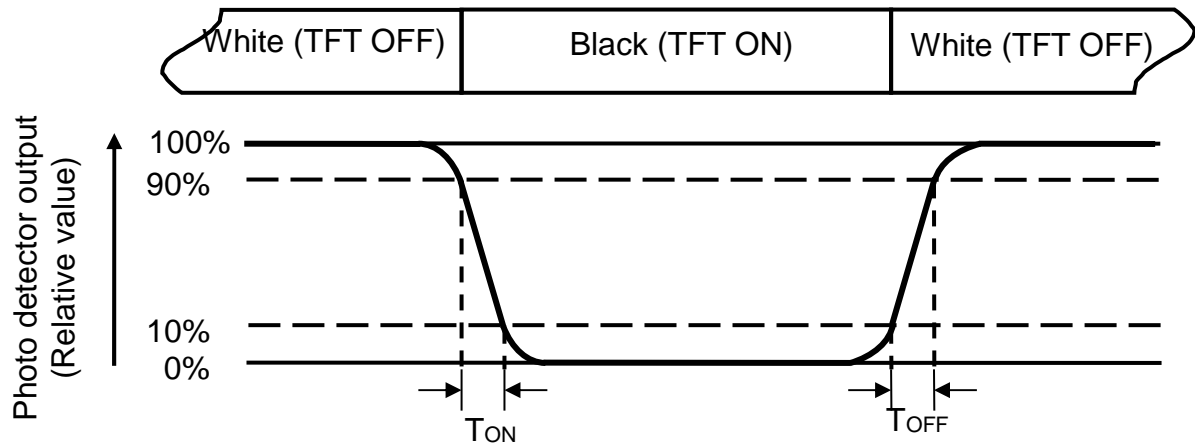

Fig. 4-3 Definition of response time

Note 4: Definition of contrast ratio

$$\text{Contrast ratio (CR)} = \frac{\text{Luminance measured when LCD on the "White" state}}{\text{Luminance measured when LCD on the "Black" state}}$$

Contrast ratio is measured at center point of LCD.

Note 5: Definition of color chromaticity (CIE1931)

Color coordinates measured at center point of LCD.

Note 6: Definition of luminance:

Measured at the center area of the panel when LCD panel is driven at "white" state. The LED driving condition is $I_L=265\text{mA}$.

Note 7: Definition of Luminance Uniformity

Active area is divided into 9 measuring areas (Refer to Fig. 4-4).Every measuring point is placed at the center of each measuring area.

$$\text{Luminance Uniformity (Yu)} = \frac{B_{min}}{B_{max}}$$

L-----Active area length W----- Active area width

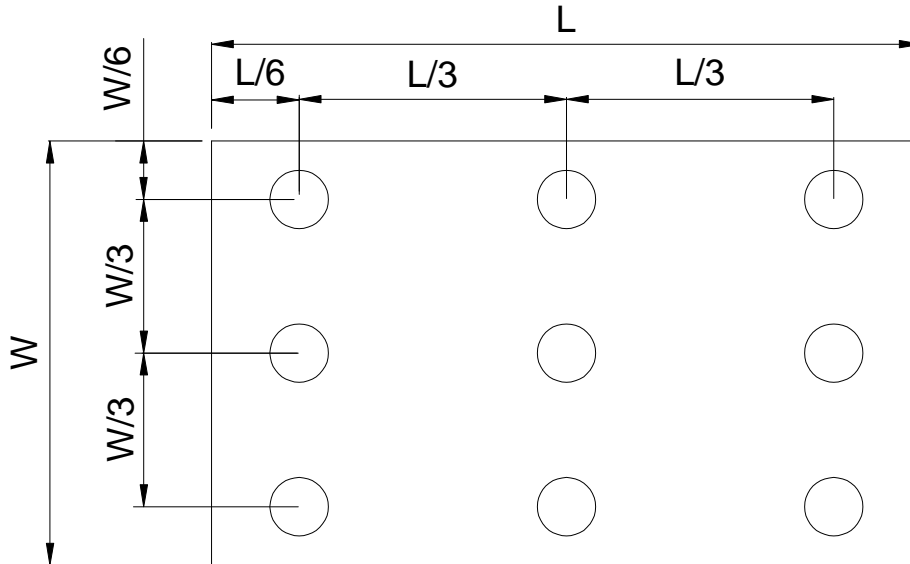

Fig. 4-4 Definition of measuring points

B_{max}: The measured maximum luminance of all measurement position.

B_{min}: The measured minimum luminance of all measurement position.

6. General Precautions

6.1. Safety

1. Liquid crystal is poisonous. Do not put it in your mouth. If liquid crystal touches your skin or clothes, wash it off immediately by using soap and water.
2. The temperature for use is no more than 80 C, otherwise, only promise the function is OK, but the quality may be changed.

6.2. Handling

1. The LCD panel is plate glass. Do not subject the panel to mechanical shock or to excessive force on its surface.
2. The polarizer attached to the display is easily damaged. Please handle it carefully to avoid scratch or other damages.
3. To avoid contamination on the display surface, do not touch the module surface with bare hands.
4. Keep a space so that the LCD panels do not touch other components.
5. Put cover board such as acrylic board on the surface of LCD panel to protect panel from damages.
6. Transparent electrodes may be disconnected if you use the LCD panel under environmental conditions where the condensation of dew occurs.
7. Do not leave module in direct sunlight to avoid malfunction of the ICs.

6.3. Static Electricity

1. Be sure to ground module before turning on power or operating module.
2. Do not apply voltage which exceeds the absolute maximum rating value.

6.4. Storage

1. Store the module in a dark room where must keep at $25\pm 10^{\circ}\text{C}$ and 65%RH or less.
2. Do not store the module in surroundings containing organic solvent or corrosive gas.
3. Store the module in an anti-electrostatic container or bag.

6.5. Cleaning

1. Do not wipe the polarizer with dry cloth. It might cause scratch.
2. Only use a soft sloth with IPA to wipe the polarizer, other chemicals might permanent damage to the polarizer.

All Pages Of This Edition Approved
Signature: _____ Date: _____



靠左上角组装

REV#	DESCRIPTION	REVISER	DATE
V0	NEW	ALECK	2001117
V1	修正印刷版	ALECK	2001120

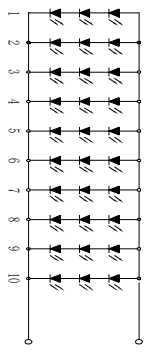
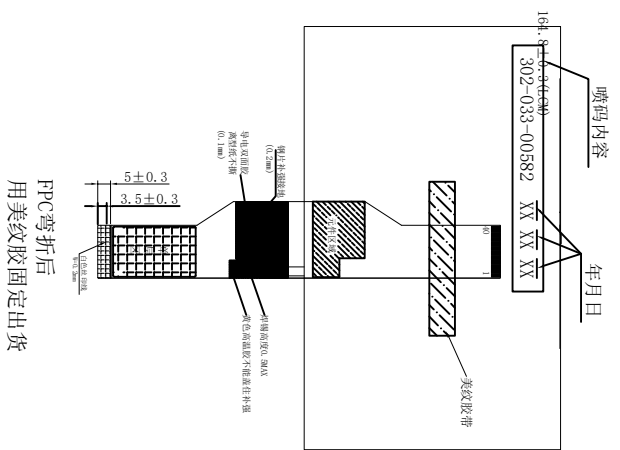
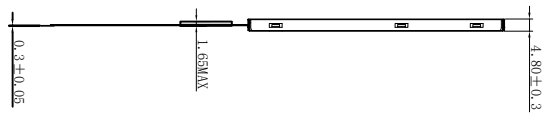
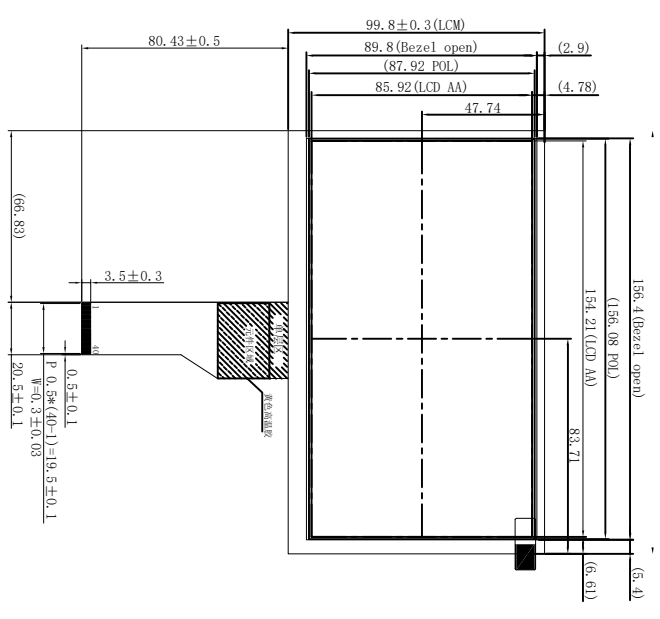

VF=9.9V IF=270mA

- NOTES:
1. DISPLAY TYPE: 7.0" 6.0 Clock
 2. Luminance: 700 cd/m²(Type)
 3. Uniformity: 75%(Min) 80%(Type)
 4. OPERATING TEMP: -20° C~+70° C
 5. STORAGE TEMP: -30° C~+80° C
 6. UNMARKER TOLERANCE: ±0.30
 7. REQUIREMENTS ON ENVIRONMENTAL PROTECTION: ROHS

备注:

Unspecified Tolerance:	±0.20	UNITS: mm	DATE:	MODEL NUMBER:		SHEET:	1 Of 1
DESIGN BY:				YH070NA-23A		DRAWING DESCRIPTION:	MODEL
CHECKED BY:							
APPROVED BY:							

Package Drawing

TBD