

- Tentative Specification
- Preliminary Specification
- Approval Specification

MODELNAME:YH080SD5002

Version:R K01

Customer: Common

APPROVED BY

SIGNATURE

Name / Title

Note

Please return 1 copy for your confirmation with your signature and comments.

Approved By	Checked By	Prepared By

Contents

1. LCM Specification.....	4
2. Mechanical Specification.....	5
3. Electrical Units.....	6
4. Timing Characteristics.....	11
5. Optical Specifications.....	14
6. Reliability Test Items.....	17
7. Handling Precautions.....	17
8. Inspection Criterion	18

1. LCM Specification

1.1 Description

YH080SD5002-RK01 is a transmissive type color active matrix liquid crystal display (LCD) which uses amorphous thin film transistor (TFT) as switching devices. This product is composed of a TFT LCD panel, a drive IC, a FPC, and a WLED-backlight unit. The active display area is 8.0 inches diagonally measured and the native resolution is 800*RGB*480. Features of this product are listed in the following table.

1.2 Functions & Features

Table1.1 Module Functions & Features

Parameter	Value	Unit
LCD Mode	a-Si TFT/transmissive	-
Color	16.7M	-
Display Resolution	800*3(RGB)*480	pixels
Outline Dimension	192.8(W) *116.9H) *6.1(T)	mm
Active Area(A.A)	176.64*(W) *99.36(H)	mm
Pixel Arrangement	RGB-stripe	-
Viewing Direction	6 O'clock	
Display Mode	Normally WHITE	
Surface Treatment	Anti-Glare,Hardness:3H	
Back-light	White LED*36CHIP	PCS
Operation Temperature	-30~85	°C
Storage Temperature	-30~85	°C

Pixel Arrangement

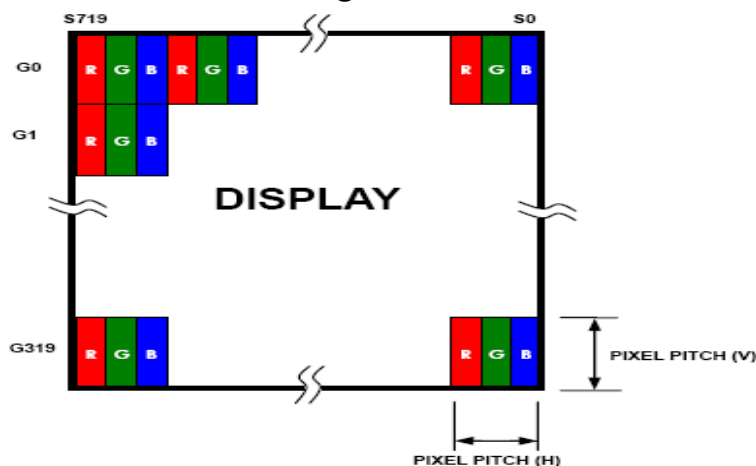

2. Mechanical Specification

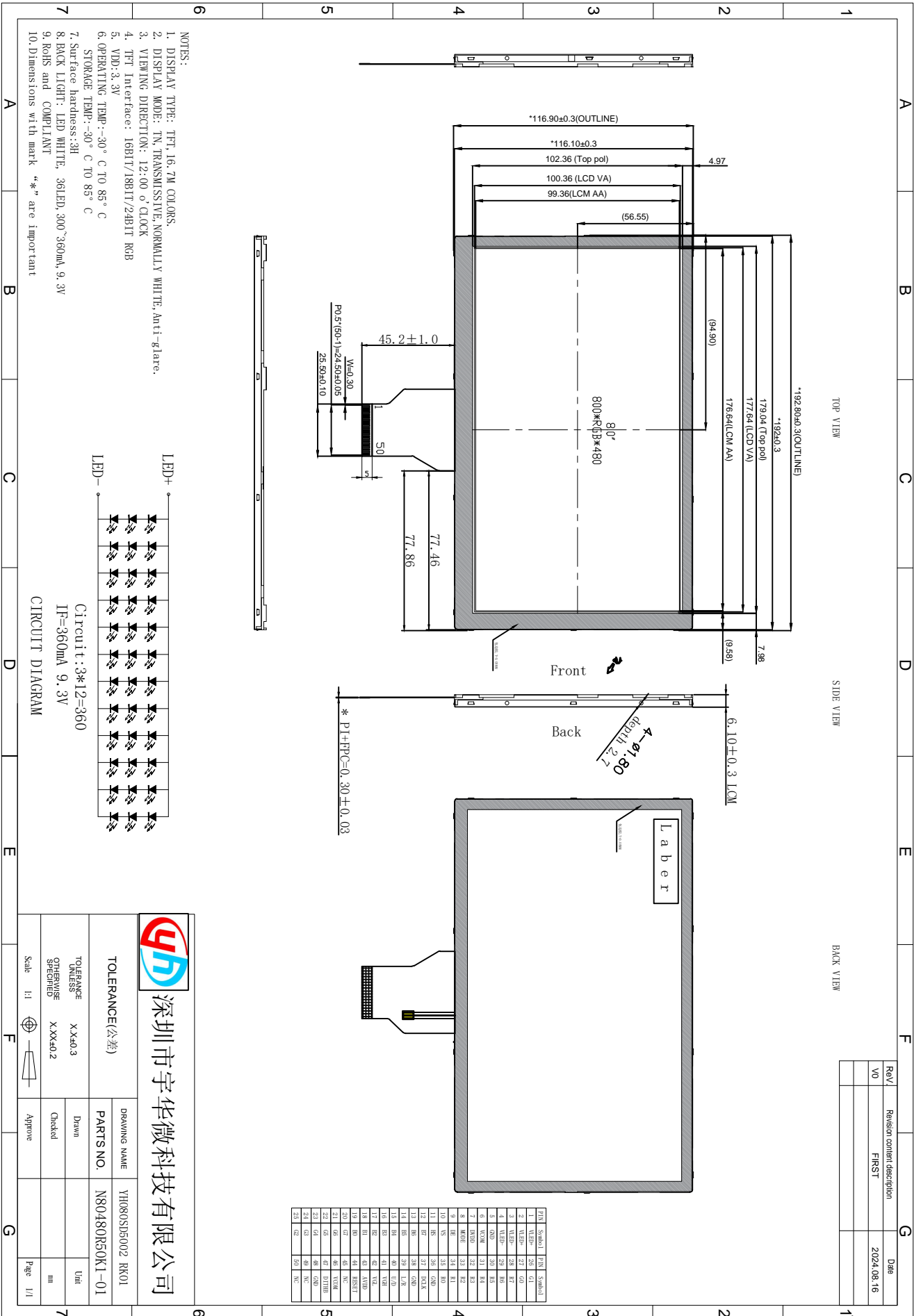

3. Electrical Units

3.1 Electrical Specification

<Table3. Electrical specifications>

Item	Symbol	Unit	Value			Note
			Min	Typ	Max	
Power voltage	DVDD	V	3.0	3.3	3.6	Note2
	AVDD	V	10.2	10.4	10.6	
	VGH	V	15.3	16	16.7	-
	VGL	V	-7.7	-7.0	-6.3	
Input signal voltage	VCOM	V	3.4	3.7	4.0	Note4
Input logic high voltage	V _{IH}	V	0.7DVDD	-	DVDD	Note3
Input logic low voltage	V _{IL}	V	0	-	0.3DVDD	

Note 1: Be sure to apply DVDD and VGL to the LCD first, and then apply VGH.

Note 2: DVDD setting should match the signals output voltage (refer to Note 3) of customer's system board.

Note 3: DCLK,HS,VS,RESET,U/D, L/R,DE,R0~R7,G0~G7,B0~B7,MODE,DITHB.

Note 4: Typical VCOM is only a reference value. It must be optimized according to each LCM. Please use VR and base on below application circuit.

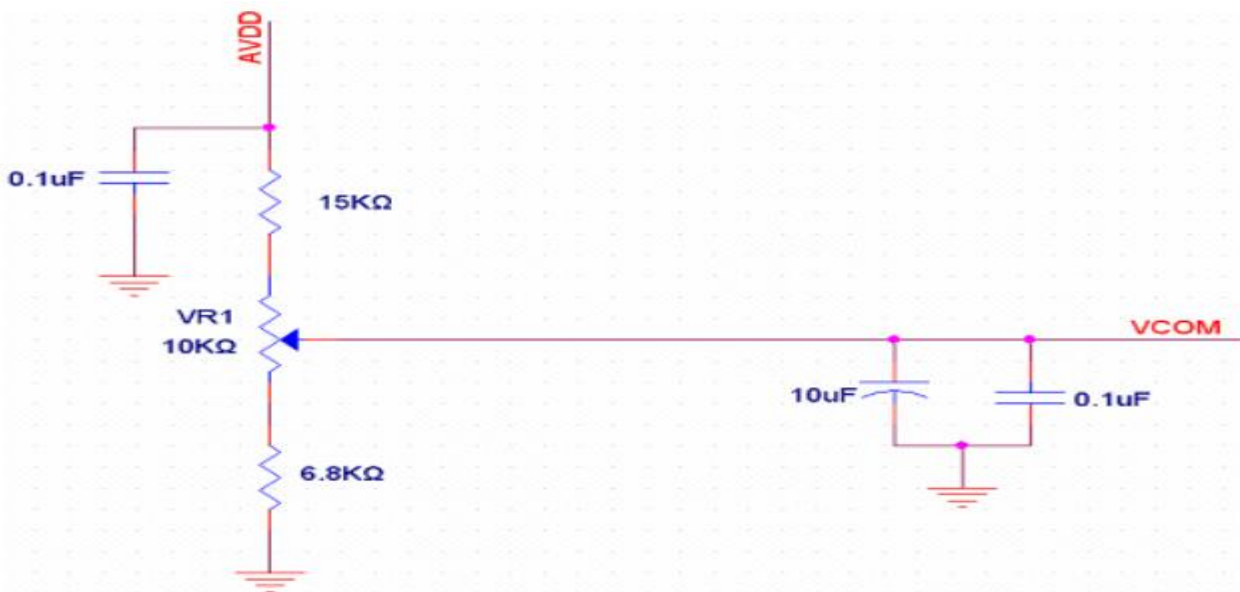

3.2 Pin Descriptions

3.2.1 TFT LCD Panel interface FPC Pin Description

Pin NO.	Function Descriptions	Symbol
1	LED Anode	LED+
2	LED Anode	LED+
3	LED Cathode	LED -
4	LED Cathode	LED -
5	Ground	GND
6	Common Voltage	VCOM
7	Digital Power	DVDD
8	DE/SYNC mode select Normally pull high H:DE mode. L:HSD/VSD mode	MODE
9	Date Enable signal	DE
10	Vertical sync input.Negative polarity	VSD
11	Horizontal sync input.Negative polarity	HSD
12	Blue Date Input(MSB)	B7
13-18	Blue Date Input	B6-B1
19	Blue Date Input(LSB)	B0
20	Green Data Input(MSB)	G7
21-26	Green Data Input	G6-G1
27	Green Data Input(LSB)	G0
28	Red Data Input(MSB)	R7
29-34	Red Data Input	R6-R1
35	Red Data Input(LSB)	R0
36	Power ground	GND
37	Clock input	DCLK
38	Ground	GND
39	Left or Right Display Control	SHLR
40	Up / Down Display Control	UPDN
41	Positive Power for TFT	VDDG
42	Negative Power for TFT	VEEG
43	Analog Power	AVDD

44	Global rest pin.Active low to enter reset state. Suggest to connecting with an RC reset circuit for stability. Normally pull high.(R=10K	RSTB
45	Not connect	NC
46	Common Voltage	VCOM
47	Dithering setting DITH= “ H ” 6bit resolution(last 2 bit of input data)truncated DITH= “H” 6bit resolution(default setting)	DITH
48	Power ground	GND
49	Not connection	NC
50	Not connection	NC

Remarks:

1)UPDN and SHLR control function

UPDN	SHLR	FUNCTION
0	1	Normal display
0	0	Inverse Left and Right
1	1	Inverse Up and Down
1	0	Inverse Left and Right Inverse Up and Down

3.3.1 Electrical characteristics (Ta=25°C)

3.3.2 TFT-LCD Current Consumption

Table 3.2:

Item	Symbol	Unit	Test Condition	Min	Typ.	Max	Note
Gate on power current	IVGH	mA	VGH=16V	-	0.2	1.0	-
Gate off power current	IVGL	mA	VGL=-7.0V	-	0.2	1.0	-
Analog power current	IVDD	mA	VDD=3.3V	-	4.0	10	-
Analog power current	IAVDD	mA	AVDD=10.4V	-	20	50	

3.3 Power Sequence

Power ON:

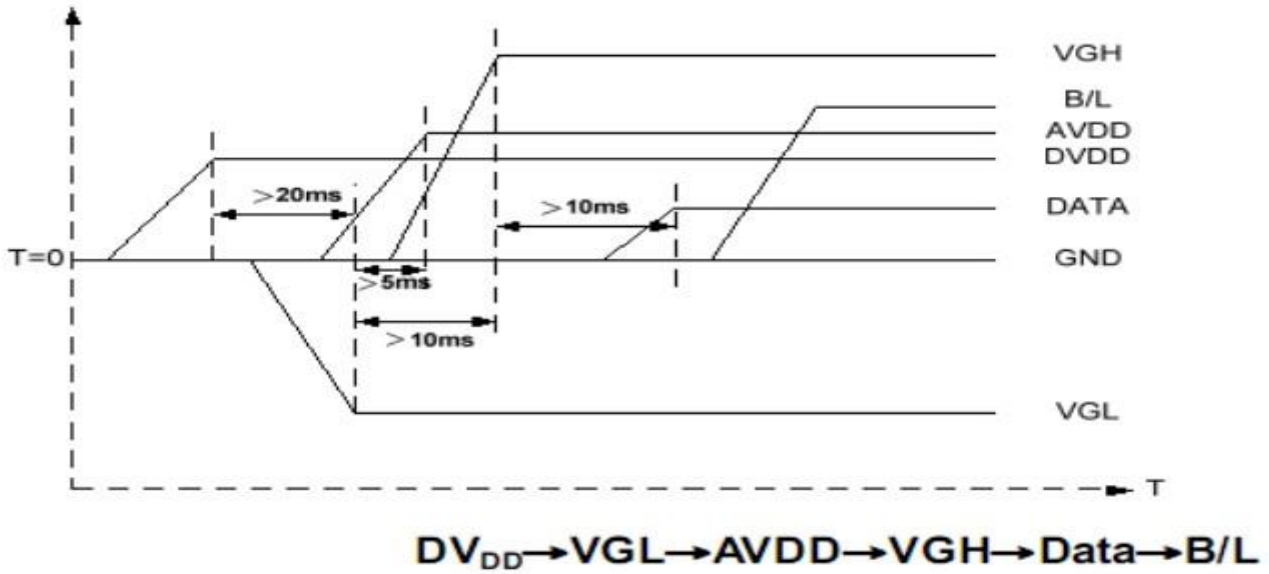

Power OFF:

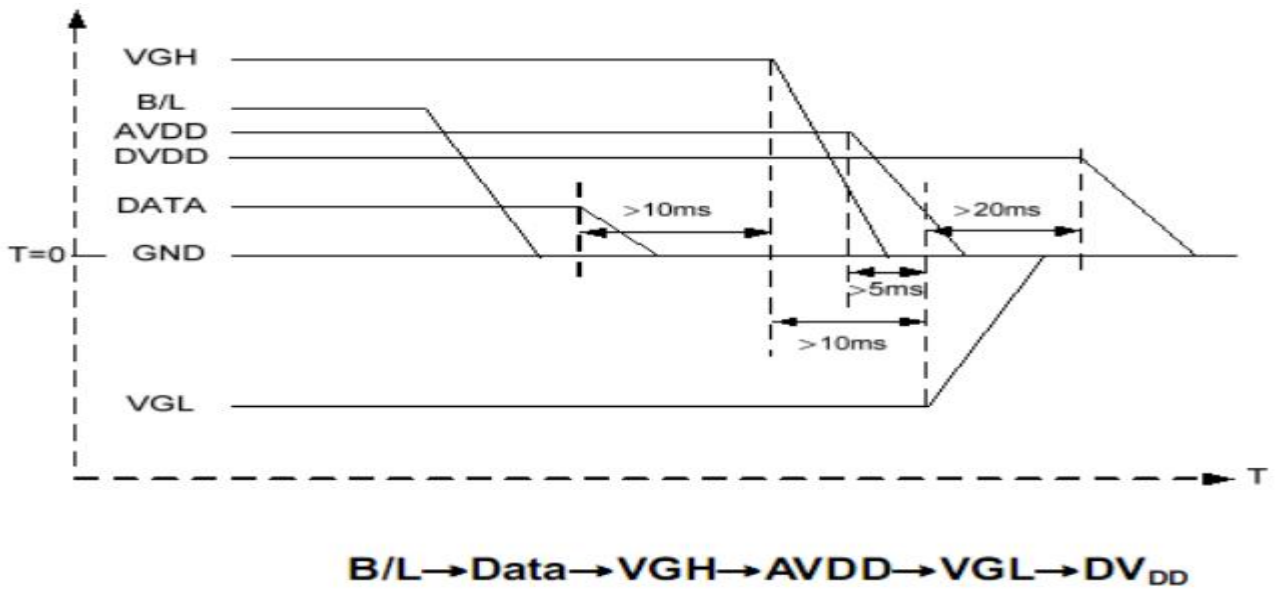

Note: Data include R0~R7, B0~B7, GO~G7, U/D, L/R, DCLK, HS,VS,DE.

3.4 Back-light Specification

Table 3.3 Back-light Specification

Item	Symbol	Conditions	Min.	Typ.	Max.	Unit
Supply Voltage	VF	Only Backlight	8.3	9.6	10.5	V
Supply Current	IF		360			mA
LED life time	-	-	30000	--	--	Hr
CIE Color Coordinate	X	Backlight Current	0.25	-	0.315	-
	Y		0.25	-	0.315	
Uniformity	B	Backlight Current		80	-	(%)
Color	White					

4. Timing Characteristics

4.1. AC Electrical Characteristics

Item	Symbol	Value			Unit	Remark
		Min	Typ	Max		
Hs setup time	THST	8			ns	
Hs hold time	THHD	8			ns	
VS setup time	TVST	8			ns	
VS hold time	TVHD	8			ns	
Data setup time	TDSU	8			ns	
Data hold time	TDHD	8			ns	
DE setup time	TESU	8			ns	
DE hold time	TEHD	8			ns	
DVDD power on slew rate	TPOR	-		20	ms	
RESET pulse width	TRST	1			ms	
DCLK cycle time	TCOH	20			ns	
DCLK pulse duty	TCWH	40	50	60	%	

4.2.2 Data Input Format

Horizontal input timing diagram

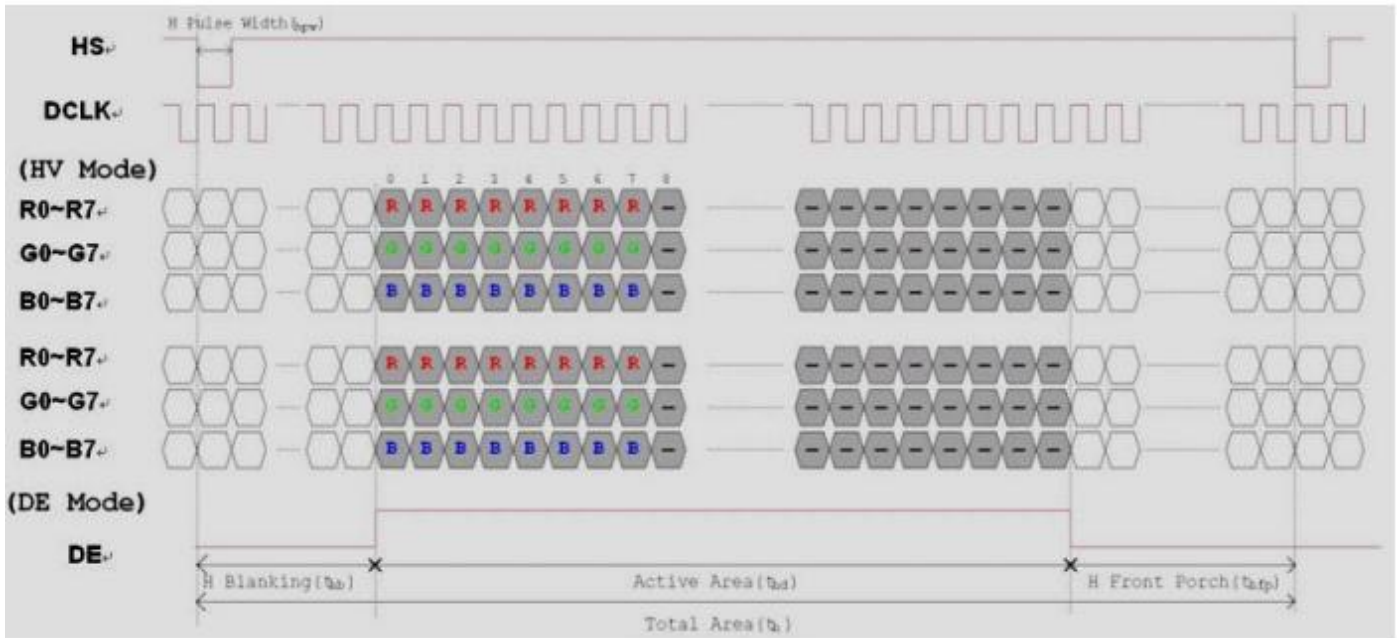

Vertical input timing diagram

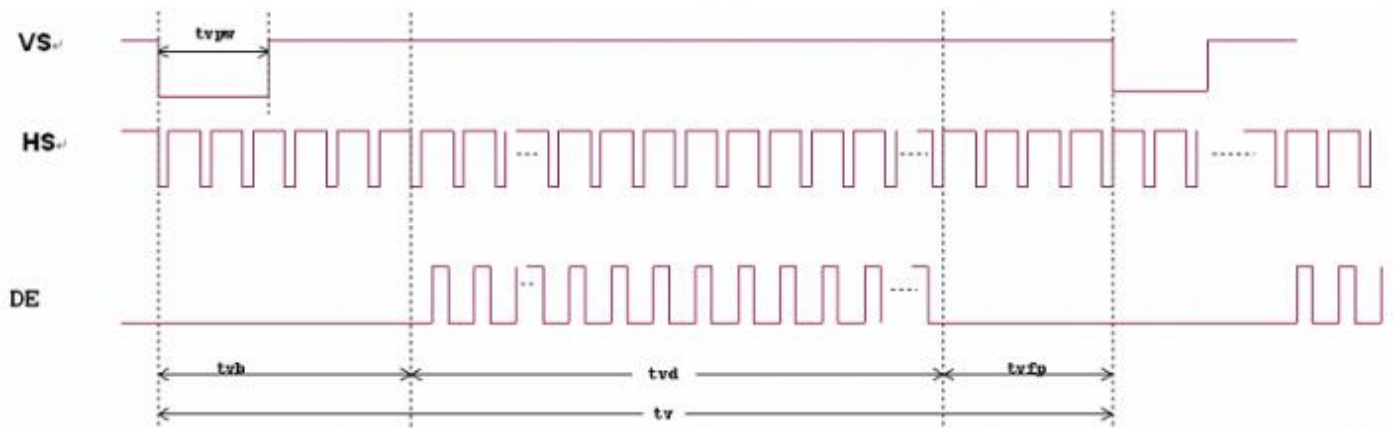

5 Optical Specifications

Item of electro-optical characteristics	Symbol	Condition	Min	Typ	Max	Unit	Remark	
Contrast ratio	CR	$\varnothing = 0^\circ$		500	--		Note1	
Surface Luminance	YL	360mA	--	800	--	Cd/M ²	Note1	
Color saturation	NTSC	-	--	50	--	%		
Response time	Ton	$\varnothing = 0^\circ$	--	10	20	ms	Note2	
	Tof		--	15	30			
Viewing angle range	$\varnothing = 0^\circ$	Top	40	50	--		Note3	
		Bottom	60	70	--			
		Left	60	70	--			
		Right	60	70	--			
Module Chromaticity CIE(x,y)	White	x	$\varnothing = 0^\circ$	0.310			Note4	
		y		0.330				
	Red	x		--	0.587			--
		y		--	0.331			--
	Green	x		--	0.344			--
		y		--	0.571			--
	Blue	x		--	0.146			--
		y		--	0.092			--
Transmittance	Trans	--	5.39	5.89	--	%	Note5	
Cross talk	Ct	--	--	--	2	%	Note6	

Notes(1) :1. All input terminals LCD panel must be ground while measuring the center area of the panel.

2. Contrast measurements shall be made at viewing angle of $\Theta = 0$ and at the center of the LCD surface. Luminance shall be measured with all pixels in the view field set first to white, then to the dark (black) state.

(see Figure 4) Luminance Contrast Ratio (CR) is defined mathematically

$$CR = \frac{\text{Luminance when displaying a white raster}}{\text{Luminance when displaying a black raster}}$$

Note (2) Definition of Response Time (TR, TF):

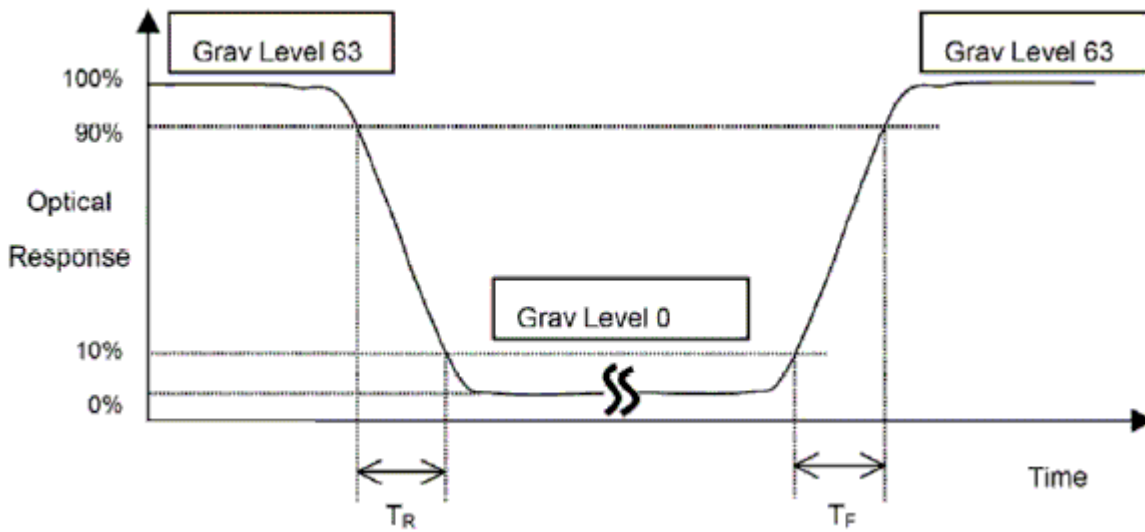

Note (3) Definition of viewing Angle:

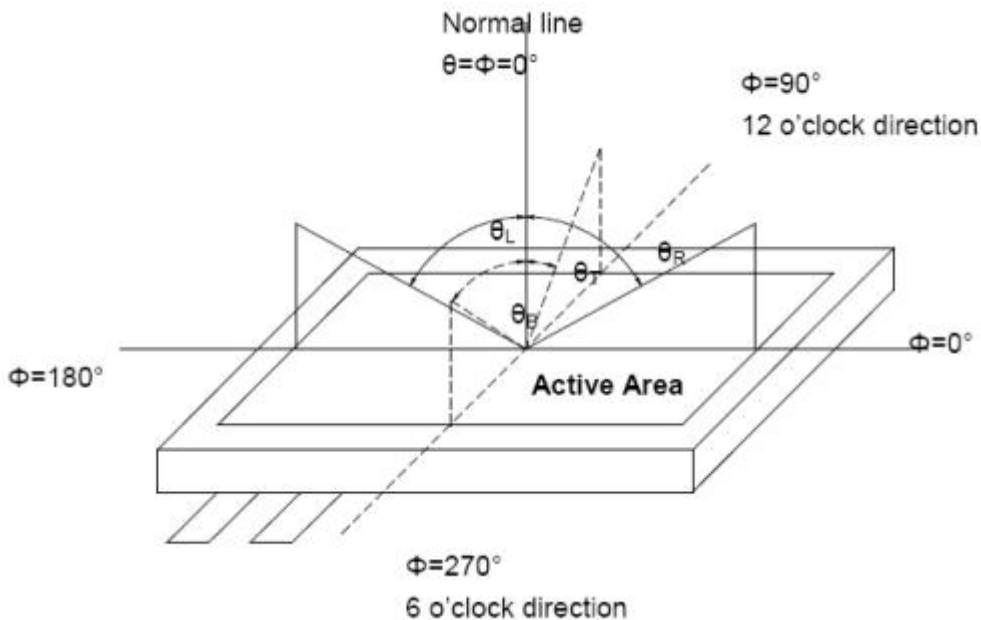

*** The above “Viewing Angle” is the measuring position with Largest Contrast Ratio; not for good image quality.

View Direction for good image quality is 6 O'clock. Module maker can increase the “Viewing Angle” by applying Wide View Film.

Note (4) Definition of optical measurement system.

The optical characteristics should be measured in dark room. The optical properties are measured at the center point of the LCD screen, (Response time is measured by Photo detector TOPCON BM-7, other items are measured by BM-5A/Field of view :1 ° /Height 500mm.)

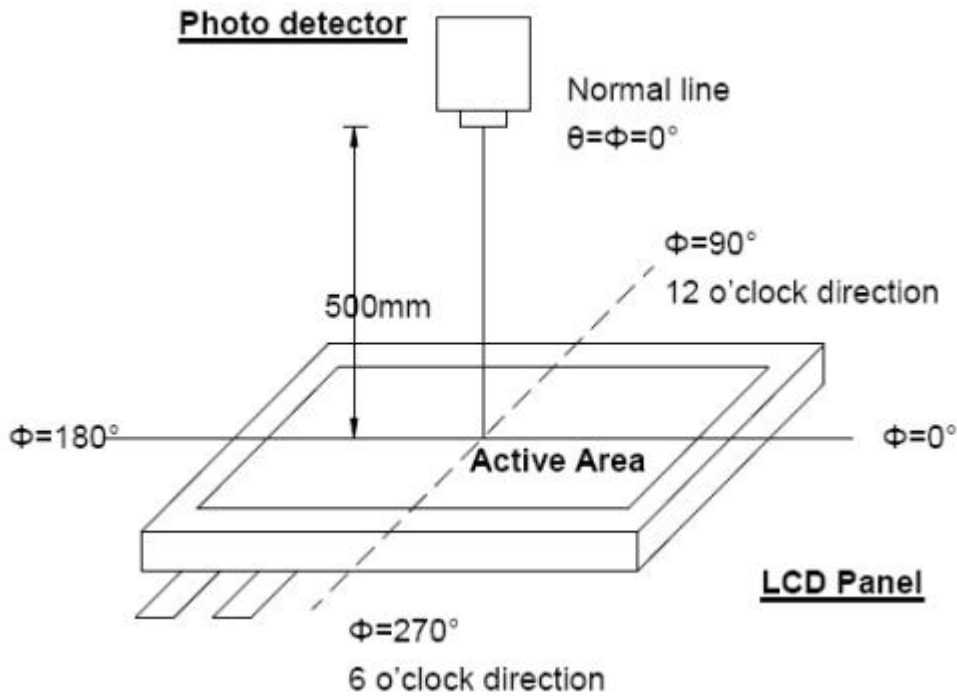

Note (5) Definition of Transmittance

Where LMOD defined as measured luminance at center point of MOD with " White" state

LBL defined as measured luminance at center point of Backlight Unit with same MOD. The

Backlight Unit has composite optical films, except "gain" characteristic optical films.

$$Tr\% = (LMOD / LBL) * 100\%$$

Note (5) Definition of crosstalk:

$$|LA - LA'| / LA \times 100\% \leq 2\% \text{ max.}, LA \text{ and } LA' \text{ are brightness at location A and } A'$$

$$|LB - LB'| / LB \times 100\% \leq 2\% \text{ max.}, LB \text{ and } LB' \text{ are brightness at location B and } B'$$

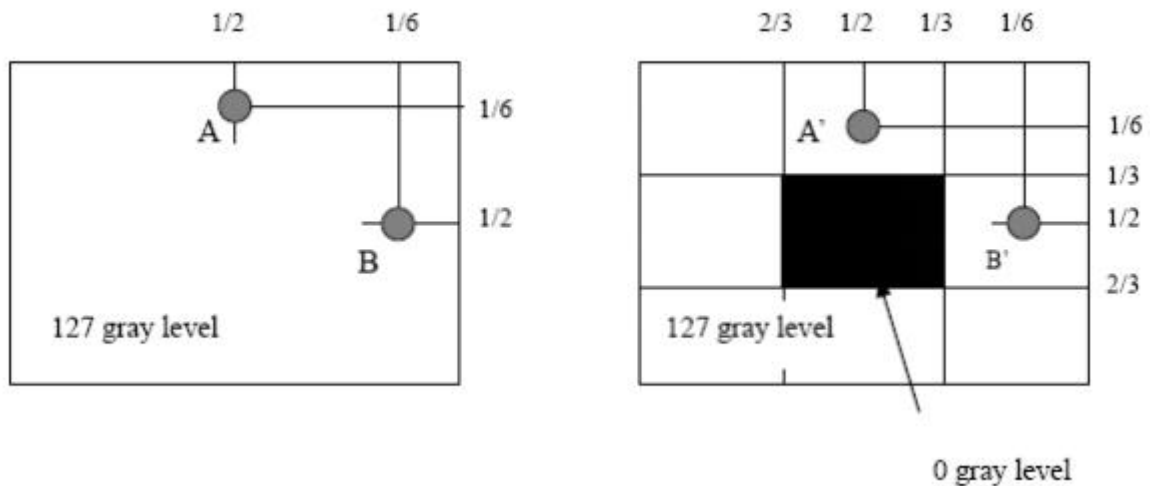

6 Reliability Test Items

NO.	Test Item	Test Condition	Check Time
1	High temp storage	T= 85	240hrs
2	Low temp storage	T=-30	240hrs
3	High temp operation	T= 85	240hrs
4	Low temp operation	T=-30	240hrs
5	High temp&high humidity	T=60 H=90%	240hrs

Reliability Test Criteria:

Display function should be no change under normal operating condition.

7. Handling Precautions

7.1 Safety

The liquid crystal in the LCD is poisonous. Keep away from your mouth and eyes. If the liquid crystal contacts with your skin, mouse or clothes, use soap to wash it off immediately.

7.2 Handling

- i. The LCD panel is made by thin glass. Prevent the panel from mechanical shock or putting excessive force on its surface.
- ii. The polarizer attached on the display is very easy to be damaged, handle it with special attention.
- iii. To avoid contamination on the display surface, do not touch the display surface with bare hands.
- iv. The transparent electrodes may be disconnected if you use the LCD panel under dew-condensing environment.
- v. The characteristics of the semiconductor devices may be affected when they are exposed to light, possibly resulting in malfunctioning of the ICs. To prevent such malfunctioning of the ICs, make sure the application and the mounting of the panel are designed so that the IC is not exposed to light.

7.3 Static Electricity

Ground soldering iron tips, tools and testers when you operate. Also ground your body when handling the products and store the products in an anti-electrostatic container.

7.4 Storage

Store the products in a dark place where the temperature is within the range of 25 ± 10 and with low humidity (65%RH or less). Do not store the LCD product in an atmosphere containing organic solvents or corrosive

gases.

7.5 Cleaning

Do not wipe the polarizer with dry cloth, as it might cause scratching. Wipe the polarizer with a soft cloth soaked with petroleum IPA. Other chemical might damage the panel.

8. INSPECTION CRITERION

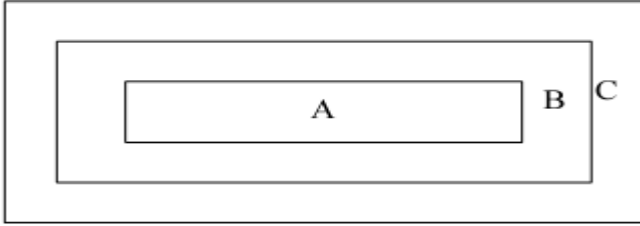
OUTGOING QUALITY STANDARD	PAGE 1 OF 6
TITLE:FUNCTIONAL TEST & INSPECTION CRITERIA	LCM Product
<p>This specification is made to be used as the standard acceptance/rejection criteria for Color mobile phone LCM with touch panel.</p> <p>1 Sample plan</p> <p>Sampling plan according to GB/T2828.1-2003/ISO 2859-1: 1999, normal level 2 and based on:</p> <p style="padding-left: 40px;">Major defect: AQL 0.65</p> <p style="padding-left: 40px;">Minor defect: AQL 1.5</p> <p>2 Inspection condition</p> <p>Viewing distance for cosmetic inspection is about 30 cm with bare eyes, and under an environment of 20~40W light intensity, all directions for inspecting the sample should be within 45° against perpendicular line.</p> <p>3 Definition of inspection zone in LCD</p> <div style="text-align: center;">  </div> <p>Zone A: character/Digit area</p> <p>Zone B: viewing area except Zone A (Zone A + Zone B=minimum Viewing area)</p>	

Zone C: Outside viewing area (invisible area after assembly in customer's product)

Fig.1 Inspection zones in an LCD.

Note: As a general rule, visual defects in Zone C are permissible, when it is no trouble for quality and assembly of customer's product.

OUTGOING QUALITY STANDARD

PAGE 2 OF 6

TITLE:FUNCTIONAL TEST & INSPECTION CRITERIA

LCM Product

4 Inspection standards

4.1 Major Defect

Item NO.	Items to be Classification	Inspection Standard	Classificatio of defects
4.1.1	All functiona defects	1) No display 2) Display abnormally 3) Missing vertical, horizontal segment defects 4) Short circuit 5) Back-light no lighting, flickering and abnormal lighting.	Major
4.1.2	Missing	Component Missing	
4.1.3	Outline dimension	Overall outline dimension beyond the drawing is not allowed.	
4.1.4	linearity	No more than 1.5%	

4.2 Cosmetic Defect

4.2.1 Spots defect

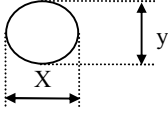
Item NO	Items to be Classification	Inspection Standard	Classificatio of defects
4.2.1	Clear Spots Black and white Spot defect Pinhole, Foreign Particle, polarizer Dirt	For dark/white spot, size Φ is define as: $\Phi = (X+Y) / 2$ 1. 	Minor

		Zone Size (mm)	Acceptable Qty		
			A	B	C
		$\Phi \leq 0.1$	Ignore		
		$0.1 < \Phi \leq 0.15$	2		
		$0.15 < \Phi \leq 0.2$	1		
$0.2 < \Phi$	0			Ignore	

OUTGOING QUALITY STANDARD	PAGE 3 OF 6
----------------------------------	--------------------

TITLE:FUNCTIONAL TEST & INSPECTION CRITERIA	LCM Product
--	--------------------

	Dim Spots Circle shaped and dim edged defects	3.			Minor	
		Zone Size (mm)	Acceptable Qty			
			A	B		C
		$\Phi \leq 0.20$	Ignore			
		$0.20 < \Phi \leq 0.40$	2			
$0.40 < \Phi \leq 0.60$	1					
$0.60 < \Phi$	0			Ignore		

4.2.2 Line defect

Item NO	Items to be Classification	Inspection Standard				Classificatio of defects
4.2.2	Line defect Black line, White line, Foreign material on polarizer	size(mm)		Acceptable Qty		
		L(Length)	W(Width)	zone		
				A	B	C
		Ignore	$W \leq 0.02$	Ignore		
		$L \leq 3.0$	$0.02 < W \leq 0.03$	2		
		$L \leq 2.0$	$0.03 < W \leq 0.05$	1		
	$0.05 < W$	Define as spot defect			Ignore	

OUTGOING QUALITY STANDARD	PAGE 4 OF 6
----------------------------------	--------------------

TITLE:FUNCTIONAL TEST & INSPECTION CRITERIA	LCM Product
--	--------------------

4.2.4	Polarize Air bubble	<table border="1"> <tr> <th rowspan="2">Zone Size (mm)</th> <th colspan="3">Acceptable Qty</th> </tr> <tr> <th>A</th> <th>B</th> <th>C</th> </tr> <tr> <td>$\Phi \leq 0.20$</td> <td colspan="3">Ignore</td> </tr> <tr> <td>$0.20 < \Phi \leq 0.30$</td> <td colspan="3">2</td> </tr> <tr> <td>$0.30 < \Phi \leq 0.50$</td> <td colspan="3">1</td> </tr> <tr> <td>$0.50 < \Phi$</td> <td colspan="3">0</td> </tr> </table>	Zone Size (mm)	Acceptable Qty			A	B	C	$\Phi \leq 0.20$	Ignore			$0.20 < \Phi \leq 0.30$	2			$0.30 < \Phi \leq 0.50$	1			$0.50 < \Phi$	0			Minor
		Zone Size (mm)		Acceptable Qty																						
			A	B	C																					
		$\Phi \leq 0.20$	Ignore																							
		$0.20 < \Phi \leq 0.30$	2																							
$0.30 < \Phi \leq 0.50$	1																									
$0.50 < \Phi$	0																									

4.2.3 LCD chip defect

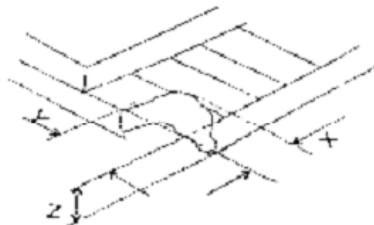
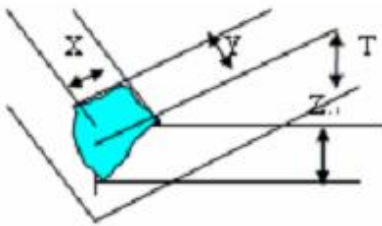
Item NO	Items to be Classification	Inspection Standard	Classificatio of defects												
4.2.5	Glass defect	<p>(i) Chips on corner A:LCD Glass defect</p>  <table border="1"> <tr> <td>X (mm)</td> <td>Y (mm)</td> <td>Z (mm)</td> </tr> <tr> <td>≤ 2.0</td> <td>$\leq S$</td> <td>Disregard</td> </tr> </table> <p>Notes: S=contact pad length Chips on the corner of terminal shall not be allowed to extend into the ITO pad or expose perimeter seal.</p> <p>B:TP Glass defect</p>  <table border="1"> <tr> <td>X (mm)</td> <td>Y (mm)</td> <td>Z (mm)</td> </tr> <tr> <td>≤ 3.0</td> <td>≤ 3.0</td> <td>Disregard</td> </tr> </table> <p>(ii)Usual surface cracks A:LCD Glass defect</p>	X (mm)	Y (mm)	Z (mm)	≤ 2.0	$\leq S$	Disregard	X (mm)	Y (mm)	Z (mm)	≤ 3.0	≤ 3.0	Disregard	Minor
X (mm)	Y (mm)	Z (mm)													
≤ 2.0	$\leq S$	Disregard													
X (mm)	Y (mm)	Z (mm)													
≤ 3.0	≤ 3.0	Disregard													

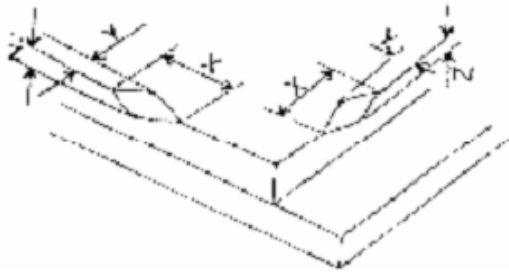

OUTGOING QUALITY STANDARD

PAGE 5 OF 6

TITLE:FUNCTIONAL TEST & INSPECTION CRITERIA

LCM Product

X (mm)	Y (mm)	Z (mm)
≤3.0	<Inner border line of the seal	Disregard

B:TP Glass defect

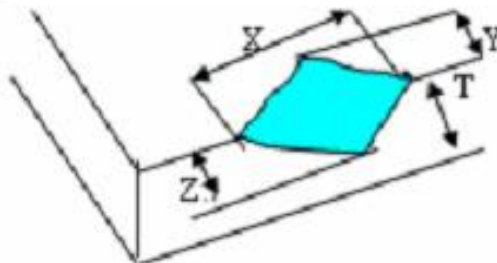

X (mm)	Y (mm)	Z (mm)
≤6.0	≤2.0	Disregard

Minor

(iii) Crack

Cracks tend to break are not allowed.

Major

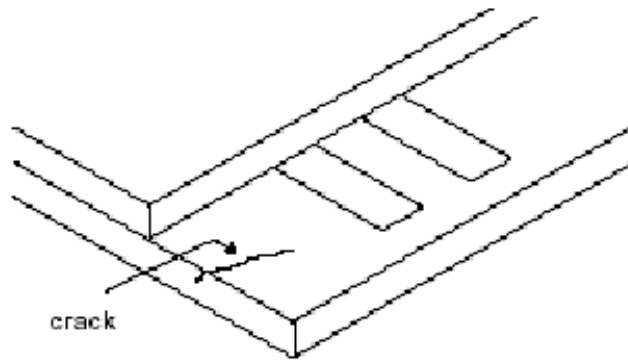

4.3 Parts Defect

Item NO	Items to be Classification	Inspection Standard	Classificatio of defects
4.3.1	Parts contraposition	1、 Not allow IC and FPC/heat-seal lead width is more than 50% beyond lead pattern. 2、 Not allow chip or solder component is off center more than 50% of the pad outline.	Major
4.3.2	SMT	According to the <Acceptability of electronic assemblies> IPC-A-610C class 2 standard. Component missing or function defect are Major defect, the others are Minor defect.	