



宇华国际科技有限公司  
YuHua INT,L Technology Co., LIMITED

Tel :0755-21010980

web:www.yhdisplay.com

**SPECIFICATION  
FOR  
LCD MODULE**

**Customer** : \_\_\_\_\_  
**Product Model:** YH090RMD5001  
**Sample code:** \_\_\_\_\_

Designed by	Checked by	Approved by

**Final Approval by Customer**

<input type="checkbox"/> <b>LCM Machinery OK</b>  Checked By _____  <input type="checkbox"/> <b>LCM Display OK</b>  Checked By _____	<input type="checkbox"/> <b>LCM OK</b>  <input type="checkbox"/> <b>NG , Problem survey:</b>  Approved By _____
--	---

※The specification of "TBD" should refer to the measured value of sample . If there is difference between the design specification and measured value, we naturally shall negotiate and agree to solution with customer.





# 宇华国际科技有限公司

## YuHua INT,L Technology Co., LIMITED

---

### Contents

<b>1. General Specifications</b> .....	<b>1</b>
<b>2. Pin Assignment</b> .....	<b>2</b>
<b>3. Operation Specifications</b> .....	<b>4</b>
3.1. Absolute Maximum Ratings .....	4
3.1.1. Typical Operation Conditions .....	4
3.1.2. Backlight Driving Conditions .....	5
3.2. Power Sequence .....	6
3.3. Timing Characteristics .....	7
<b>4. Optical Specifications</b> .....	<b>8</b>
<b>5. Reliability Test Items</b> .....	<b>12</b>
<b>6. General Precautions</b> .....	<b>13</b>
6.1. Safety .....	13
6.2. Handling.....	13
6.3. Static Electricity.....	13
6.4. Storage .....	13
6.5. Cleaning.....	13
<b>7. Mechanical Drawing</b> .....	<b>14</b>



## 1. General Specifications

Page:1/14

No.	Item	Specification	Remark
1	LCD size	9.0 inch(Diagonal)	
2	Driver element	a-Si TFT active matrix	
3	Resolution	800 × 3(RGB) × 480	
4	Display mode	Normally White, Transmissive	
5	Dot pitch	0.0825(W) × 0.2327(H) mm	
6	Active area	198.0(W) × 111.696 (H) mm	
7	Module size	210.7(W) × 126.4 (H) 6.95(D) mm	Note
8	Surface treatment	Anti-Glare	
9	Color arrangement	RGB-stripe	
10	Interface	Digital	
11	Backlight power consumption	0.99W	
12	Panel power consumption	0.360W	
13	Weight	TBD	

Note 1: Refer to Mechanical Drawing.



## 2. Pin Assignment

1	VLED+	Power for LED backlight(Anode)
2	VLED+	Power for LED backlight(Anode)
3	VLED-	Power for LED backlight(Cathode)
4	VLED-	Power for LED backlight(Cathode)
5	GND	Power ground
6	VCOM	Common voltage
7	DVDD	Power for Digital Circuit
8	MODE	DE/SYNC mode select
9	DE	Data input enable
10	VS	Vertical sync input
11	HS	Horizontal sync input
12	B7	Blue data
13	B6	Blue data
14	B5	Blue data
15	B4	Blue data
16	B3	Blue data
17	B2	Blue data
18	B1	Blue data
19	B0	Blue data
20	G7	Green data
21	G6	Green data
22	G5	Green data
23	G4	Green data
24	G3	Green data
25	G2	Green data
26	G1	Green data
27	G0	Green data
28	R7	Red data



29	R6	Red data
30	R5	Red data
31	R4	Red data
32	R3	Red data
33	R2	Red data
34	R1	Red data
35	R0	Red data
36	GND	Power Ground
37	DCLK	Clock Signal Input
38	GND	Power Ground
39	L/R	Left/right select
40	U/D	UP/down select
41	VGH	Gate on voltage
42	VGL	Gate off voltage
43	AVDD	Power for Analog circuit
44	RESET	Global reset pin
45	NC	No connection
46	VCOM	Common voltage
47	DITHB	Dithering function
48	GND	Power Ground
49	NC	No connection
50	NC	No connection

I: input, O: output, P: Power

Note 1: DE/SYNC mode select. Normally pull high.

When select DE mode, MODE="1", VS and HS must pull high.

When select SYNC mode, MODE="0", DE must be grounded.

Note 2: When input 18 bits RGB data, the two low bits of R,G and B data must be grounded.

Note 3: Data shall be latched at the falling edge of DCLK.



### 3. Operation Specifications

#### 3.1 Absolute Maximum Ratings

(Note 1)

Item	Symbol	Values		Unit	Remark
		Min.	Max.		
Supply voltage	V <sub>DD</sub>	-0.3	5.0	V	(1) (2)
Operation Temperature	T <sub>OP</sub>	-10	60	°C	(1) (2)
Storage Temperature	T <sub>ST</sub>	-20	70	°C	(1) (2)
Analog Power Supply	AVDD	-0.5	13.5	V	(1) (2)
TFT Device on voltage	V <sub>GH</sub>	13.0	19.0	V	(1) (2)
TFT Device off voltage	V <sub>GL</sub>	-12.0	-2.0	V	(1) (2)

Note 1: All of voltages listed above are with respect to GND = 0V

Note 2: Device is subject to be damaged permanently if stresses beyond those absolute maximum ratings listed above.

#### 2.1.1. Typical Operation Conditions

Item	Symbol	Values			Unit	Remark
		Min.	Typ.	Max.		
Power voltage	DV <sub>DD</sub>	3.0	3.3	3.6	V	Note 2
	AV <sub>DD</sub>	10.2	10.4	10.6	V	
	V <sub>GH</sub>	16.3	17.0	17.7	V	
	V <sub>GL</sub>	-5.7	-5.0	-4.3	V	
Input signal voltage	V <sub>COM</sub>	4.0	4.2	4.4	V	
Input logic high voltage	V <sub>IH</sub>	0.7 DV <sub>DD</sub>	-	DV <sub>DD</sub>	V	Note 3
Input logic low voltage	V <sub>IL</sub>	0	-	0.3 DV <sub>DD</sub>	V	



Note 1: Be sure to apply  $DV_{DD}$  and  $V_{GL}$  to the LCD first, and then apply  $V_{GH}$ .

Note 2:  $DV_{DD}$  setting should match the signals output voltage (refer to Note 3) of customer's system board.

Note 3: DCLK, HS, VS, RESET, U/D, L/R, DE, R0~R7, G0~G7, B0~B7, MODE, DITHB.

Item	Symbol	Values			Unit	Remark
		Min.	Typ.	Max.		
Current for Driver	$I_{GH}$	-	0.3	1	mA	$V_{GH} = 17.0V$
	$I_{GL}$	-	0.3	1	mA	$V_{GL} = -5.0V$
	$IDV_{DD}$	-	5.5	10	mA	$V_{CC} = 3.3V$
	$I_{AV_{DD}}$	-	32	50	mA	$AV_{DD} = 10.4V$

### 2.1.2. Backlight Driving Conditions

Item	Symbol	Values			Unit	Remark
		Min.	Typ.	Max.		
Voltage for LED backlight	$V_L$	9.3	9.9	10.5	V	Note 1
Current for LED backlight	$I_L$	-	180	-	mA	
LED life time	-	-	20,000	-	Hr	Note 2

Note 1: The LED Supply Voltage is defined by the number of LED at  $T_a=25^{\circ}C$  and  $I_L=180mA$ .

Note 2: The "LED life time" is defined as the module brightness decrease to 50% original brightness at  $T_a=25^{\circ}C$  and  $I_L=180mA$ . The LED lifetime could be decreased if operating  $I_L$  is larger than 100mA.



## 2.2. Power Sequence

### 2.1. Power on:

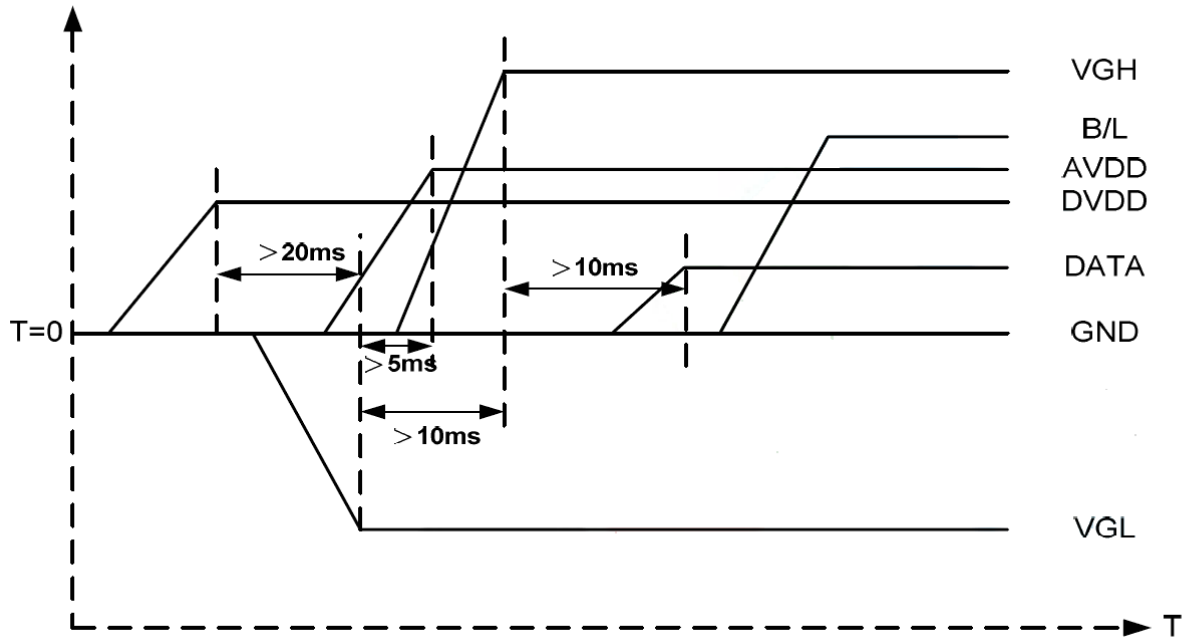

**DVDD→VGL→VGH→Data→B/L**

### 2.2. Power off:

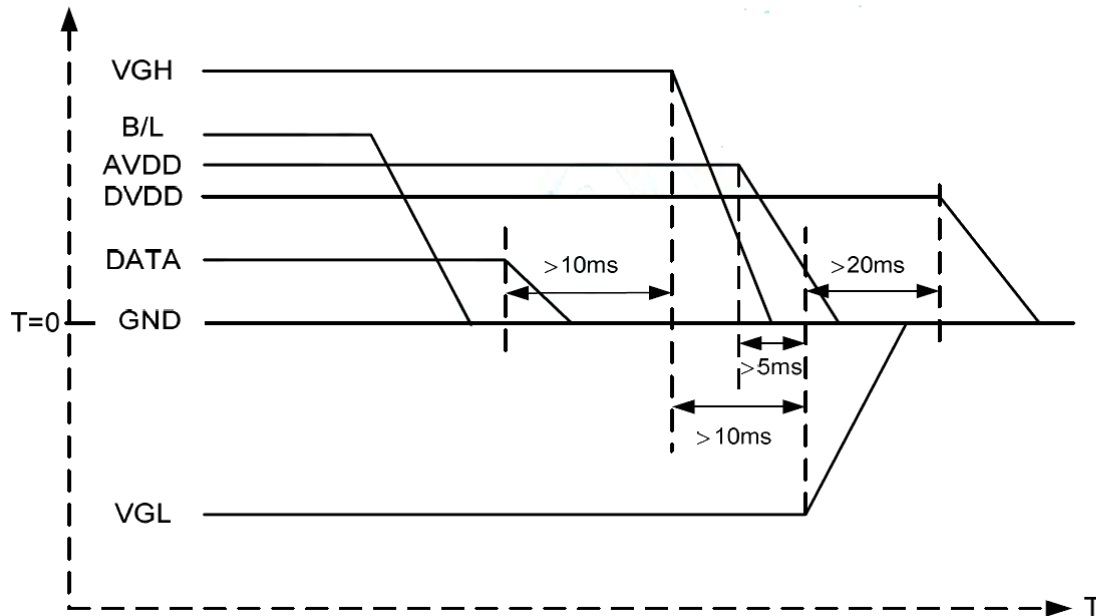

**B/L→Data→VGH→VGL→DVDD**

Note: Data include R0~R7, B0~B7, GO~G7, U/D, L/R, DCLK, HS,VS,DE.



### 2.3. Timing Characteristics

Item	Symbol	Values			Unit	Remark
		Min.	Typ.	Max.		
Horizontal Display Area	thd	-	800	-	DCLK	
DCLK Frequency	fclk	26.4	33.3	46.8	MHz	
One Horizontal Line	th	862	1056	1200	DCLK	
HS pulse width	thpw	1	-	40	DCLK	
HS Blanking	thb	46	46	46	DCLK	
HS Front Porch	thfp	16	210	354	DCLK	

Item	Symbol	Values			Unit	Remark
		Min.	Typ.	Max.		
Vertical Display Area	tvd	-	480	-	TH	
VS period time	tv	510	525	650	TH	
VS pulse width	tvpw	1	-	20	TH	
VS Blanking	tvb	23	23	23	TH	
VS Front Porch	tvfp	7	22	147	TH	



### 3. Optical Specifications

Item	Symbol	Condition	Values			Unit	Remark
			Min.	Typ.	Max.		
Viewing angle (CR≥ 10)	$\theta_L$	$\Phi=180^\circ$ (9 o'clock)	60	70	-	degree	Note 1
	$\theta_R$	$\Phi=0^\circ$ (3 o'clock)	60	70	-		
	$\theta_T$	$\Phi=90^\circ$ (12 o'clock)	40	50	-		
	$\theta_B$	$\Phi=270^\circ$ (6 o'clock)	60	70	-		
Response time	$T_{ON}$	Normal $\theta=\Phi=0^\circ$	-	10	20	msec	Note 3
	$T_{OFF}$		-	15	30	msec	Note 3
Contrast ratio	CR		400	500	-	-	Note 4
Color chromaticity	$W_X$		0.26	0.31	0.36	-	Note 2
	$W_Y$		0.28	0.33	0.38	-	Note 5 Note 6
Luminance	L		200	250	-	cd/m2	Note 6
Luminance uniformity	$Y_U$		70	75	-	%	Note 7

**Test Conditions:**

1.  $V_{DD}=3.3V$ ,  $I_L=180mA$  (Backlight current), the ambient temperature is  $25^\circ C$ .
2. The test systems refer to Note 2.



# 宇华国际科技有限公司

## YuHua INT,L Technology Co., LIMITED

Note 1: Definition of viewing angle range

Page:9/14

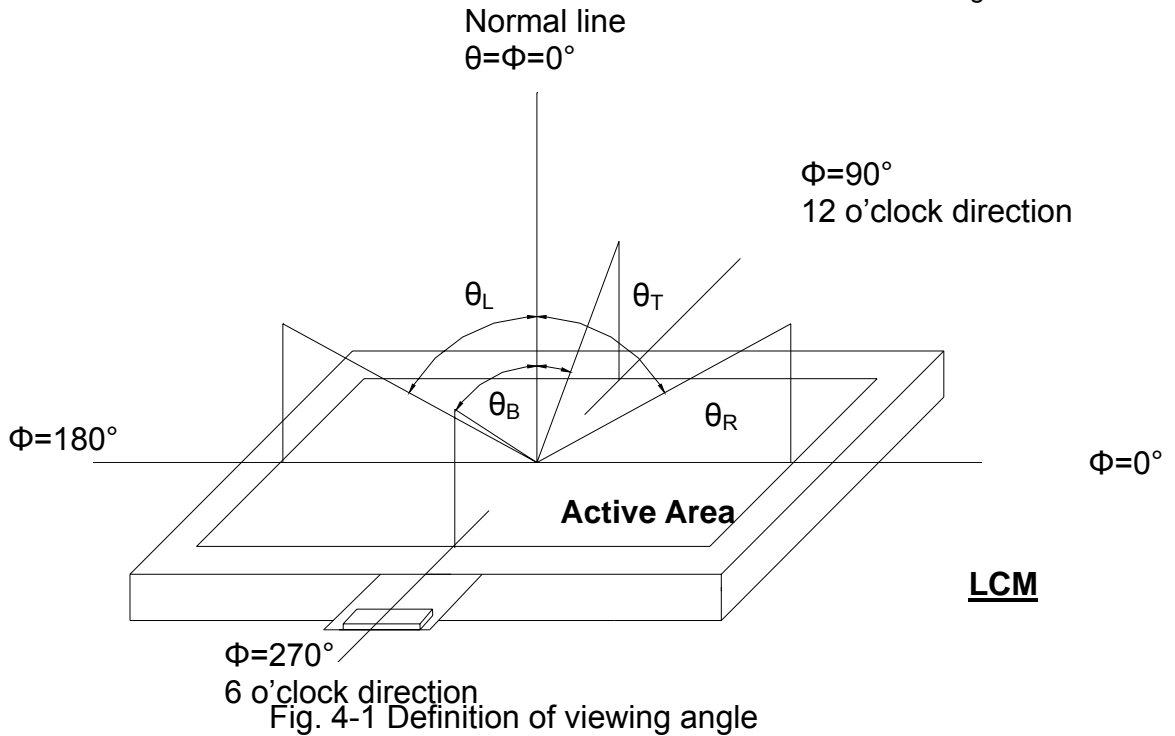

Fig. 4-1 Definition of viewing angle

Note 2: Definition of optical measurement system.

The optical characteristics should be measured in dark room. After 30 minutes operation, the optical properties are measured at the center point of the LCD screen. (Response time is measured by Photo detector TOPCON BM-7, other items are measured by BM-5A/Field of view:  $1^\circ$  /Height: 500mm.)

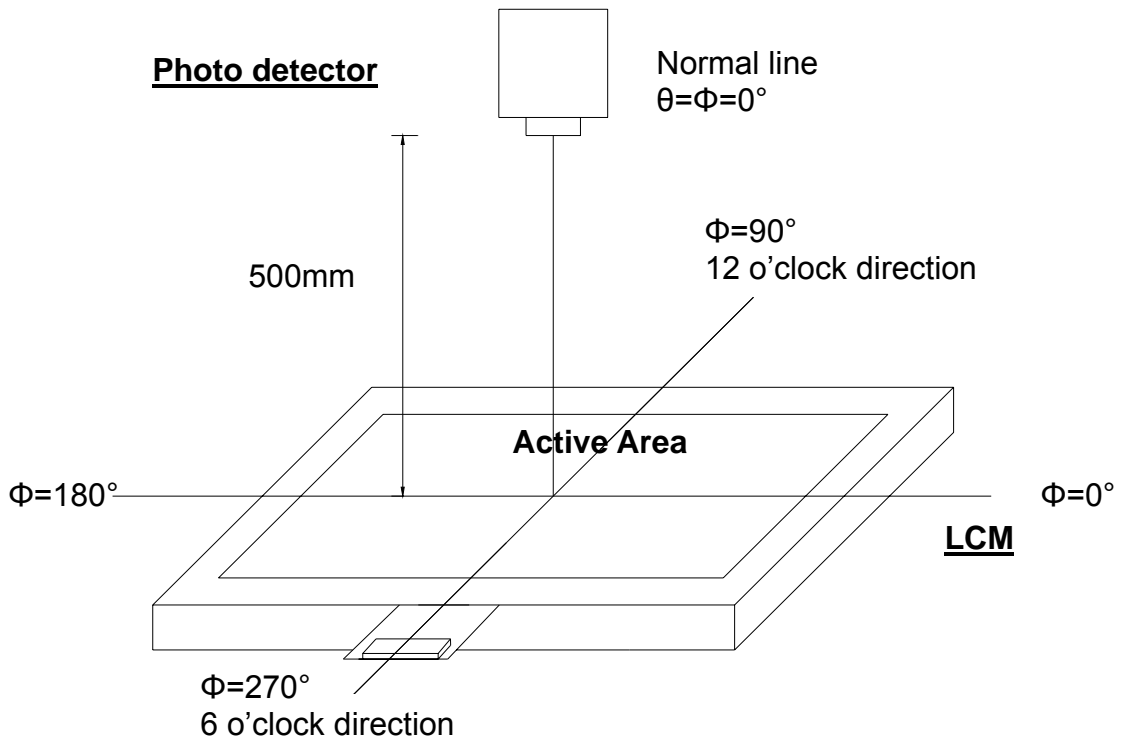



Fig. 4-2 Optical measurement system setup

Note 3: Definition of Response time

The response time is defined as the LCD optical switching time interval between "White" state and "Black" state. Rise time ( $T_{ON}$ ) is the time between photo detector output intensity changed from 90% to 10%. And fall time ( $T_{OFF}$ ) is the time between photo detector output intensity changed from 10% to 90%.

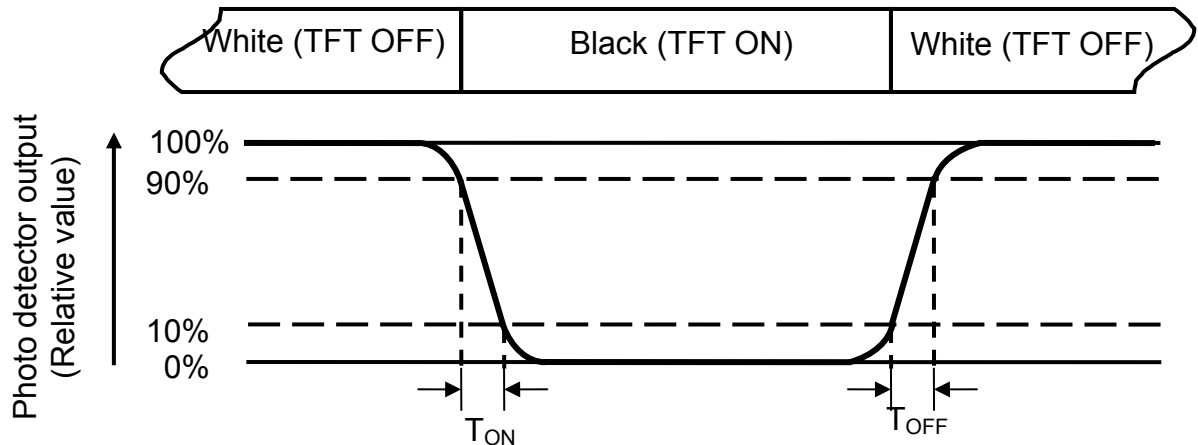

Fig. 4-3 Definition of response time

Note 4: Definition of contrast ratio

$$\text{Contrast ratio (CR)} = \frac{\text{Luminance measured when LCD on the "White" state}}{\text{Luminance measured when LCD on the "Black" state}}$$

Note 5: Definition of color chromaticity (CIE1931)

Color coordinates measured at center point of LCD.

Note 6: All input terminals LCD panel must be ground while measuring the center area of the panel. The LED driving condition is  $I_L=180\text{mA}$ .



Note 7: Definition of Luminance Uniformity

Active area is divided into 9 measuring areas (Refer to Fig. 4-4 ).Every measuring point is placed at the center of each measuring area.

$$\text{Luminance Uniformity (Yu)} = \frac{B_{min}}{B_{max}}$$

L-----Active area length      W----- Active area width

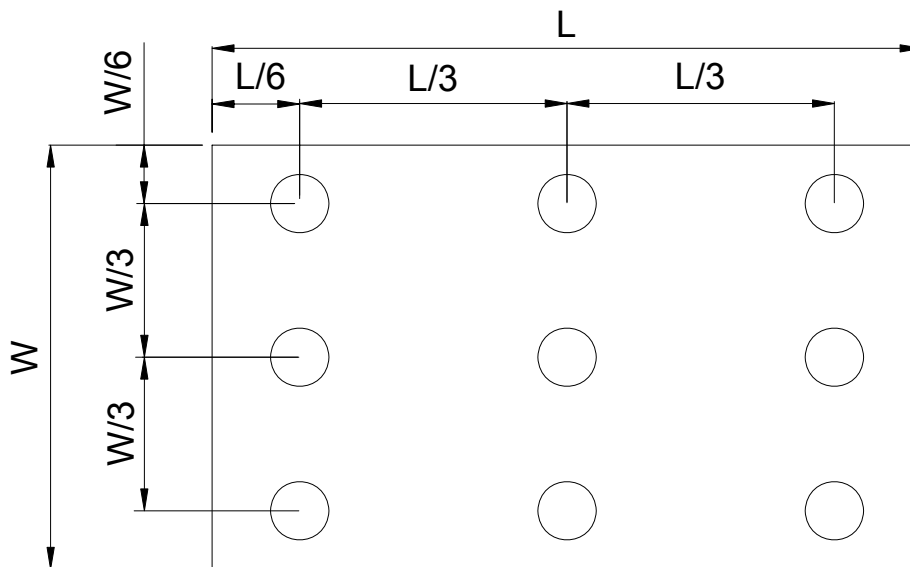

Fig. 4-4 Definition of measuring points

$B_{max}$ : The measured maximum luminance of all measurement position.  
 $B_{min}$ : The measured minimum luminance of all measurement position.





## 5. General Precautions

### 5.1. Safety

Liquid crystal is poisonous. Do not put it in your mouth. If liquid crystal touches your skin or clothes, wash it off immediately by using soap and water.

### 5.2. Handling

1. The LCD panel is plate glass. Do not subject the panel to mechanical shock or to excessive force on its surface.
2. The polarizer attached to the display is easily damaged. Please handle it carefully to avoid scratch or other damages.
3. To avoid contamination on the display surface, do not touch the module surface with bare hands.
4. Keep a space so that the LCD panels do not touch other components.
5. Put cover board such as acrylic board on the surface of LCD panel to protect panel from damages.
6. Transparent electrodes may be disconnected if you use the LCD panel under environmental conditions where the condensation of dew occurs.
7. Do not leave module in direct sunlight to avoid malfunction of the ICs.

### 5.3. Static Electricity

1. Be sure to ground module before turning on power or operating module.
2. Do not apply voltage which exceeds the absolute maximum rating value.

### 5.4. Storage

1. Store the module in a dark room where must keep at  $25\pm 10^{\circ}\text{C}$  and 65%RH or less.
2. Do not store the module in surroundings containing organic solvent or corrosive gas.
3. Store the module in an anti-electrostatic container or bag.

### 5.5. Cleaning

1. Do not wipe the polarizer with dry cloth. It might cause scratch.
2. Only use a soft sloth with IPA to wipe the polarizer, other chemicals might permanent damage to the polarizer.

## 6. Mechanical Drawing

序号	更改记录	记录人	日期
A			
B			

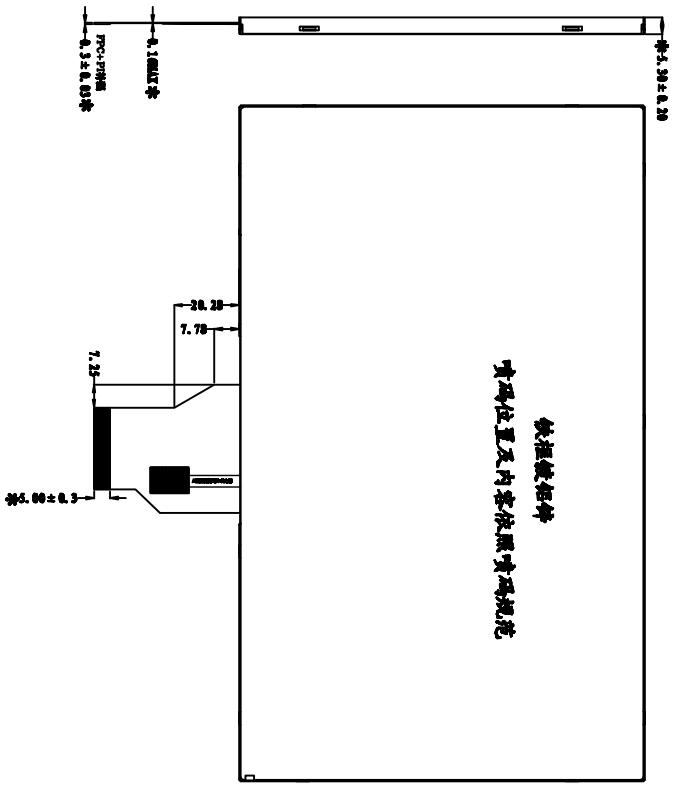
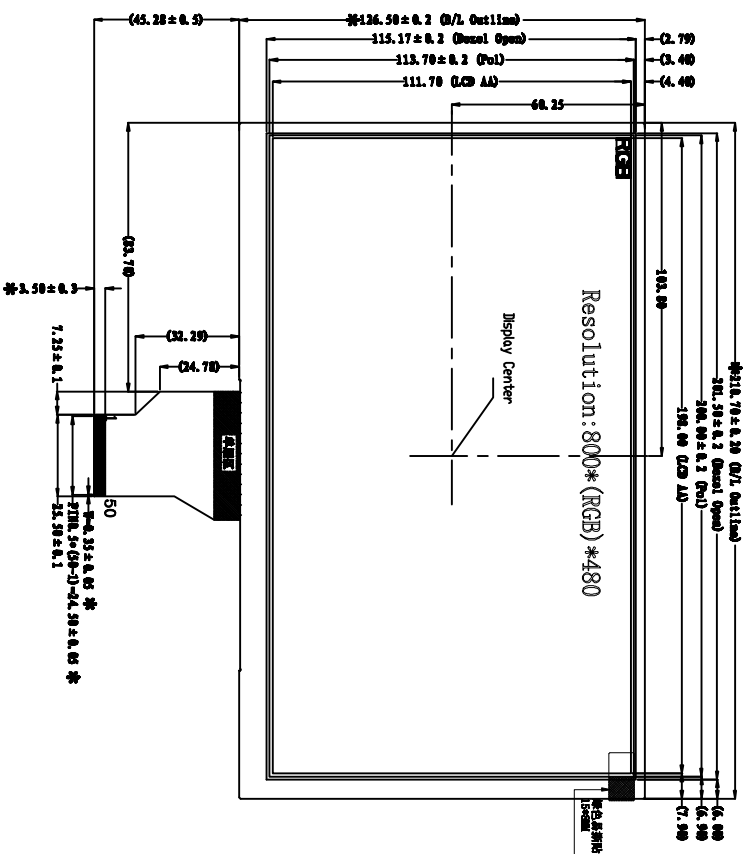

Specification:

- 1). Viewing angle: 6 O'clock
- 2). Display mode: a-Si TFT/Transmissive/Normal White
- 3). Operating temp.: -20° C +70° C  
Storage temp.: -30° C +80° C
- 4). BL LBD: 27 CHIP-WHITE LBDs, I<sub>f</sub>=180mA
- 5). Key dimensions: 350cd/m<sup>2</sup>(TYP)
- 6). All the raw material are Rohs compliant

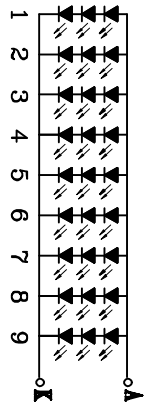

DRAWN BY:	TITLE:	VIEW:
CHECKED BY:	CUSTOMER ID:	比例: 1:1
APPROVED BY:	VERSION NUMBER:	UNIT: mm
DATE:	DATE:	SCALE: 1:1

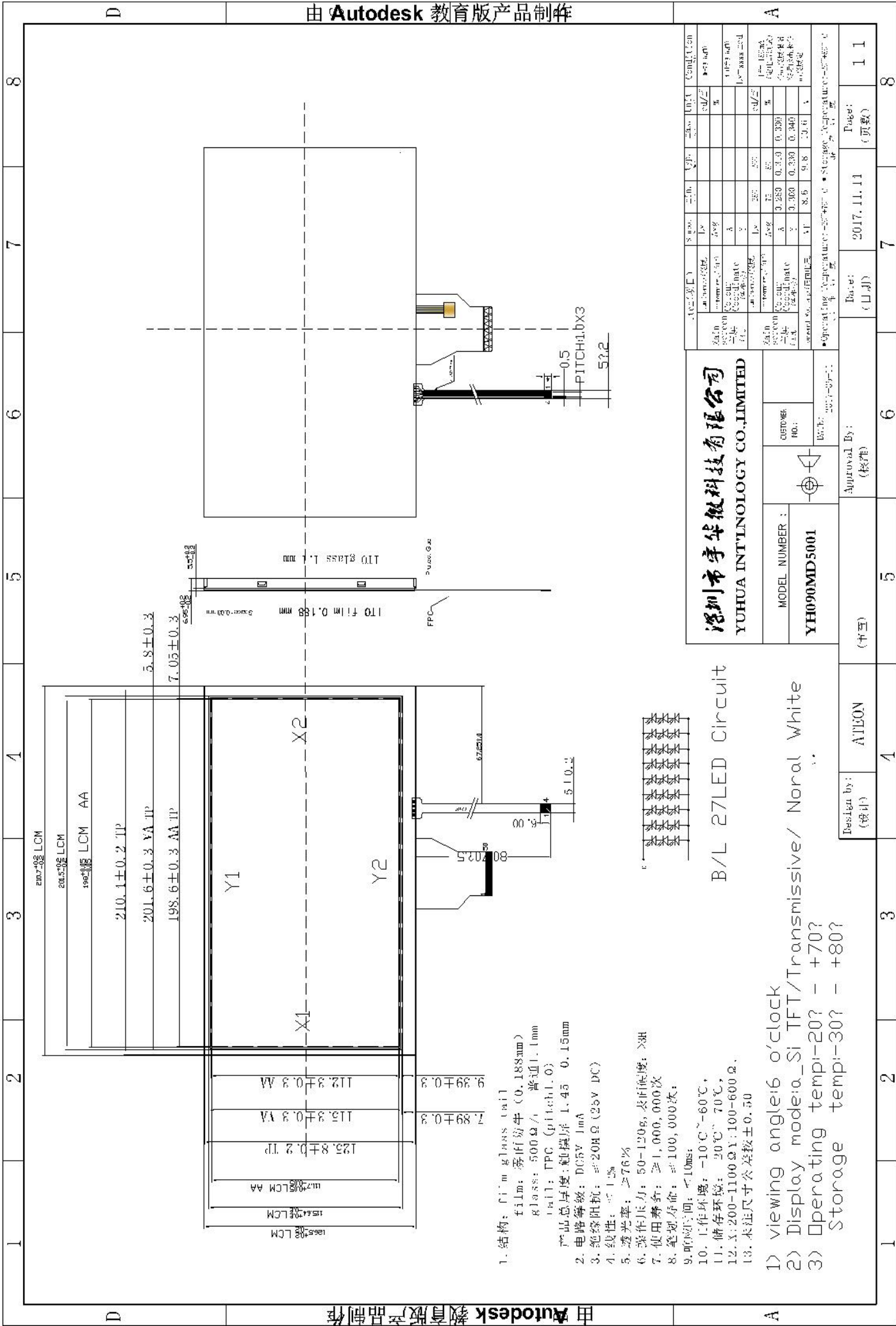

1. 结构: Film glass tail  
film: 秀研易牛 (0.188mm)  
glass: 500Ω/ 普通1.1mm  
tail: FPC (pitch:1.0)  
产品总厚度: 总厚度 1.45 0.15mm
2. 电路等级: DC5V 1mA
3. 绝缘阻抗: ≥20MΩ (25v DC)
4. 线性: ≥1.5%
5. 透光率: ≥76%
6. 操作压力: 50-120g, 表面硬度: >3H
7. 使用寿命: ≥1,000,000次
8. 笔划寿命: ≥100,000次
9. 响应时间: ≤10ms
10. 工作环境: -10°C~60°C
11. 储存环境: 20°C~70°C
12. X: 200-1100Ω; Y: 100-600Ω
13. 未注尺寸公差按±0.50

- 1) viewing angle: 6 o'clock
- 2) Display mode: a\_Si TFT/Transmissive/ Noral White
- 3) Operating temp: -20? - +70?  
Storage temp: -30? - +80?

B/L 27LED Circuit

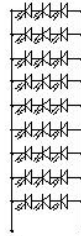

深圳市宇华微科技有限公司  
YUHUA INT'LNOLOGY CO.,LIMITED

MODEL NUMBER :	YH090MD5001
CUSTOMER NO.:	
DATE:	2017-11-11

Design by: (设计) AULEON  
Approval By: (校作)

Main Screen Size		S. max		V. max		C. max		Condition	
mm	inch	mm	inch	mm	inch	mm	inch	mm	inch
Avg		Avg		Avg		Avg		112.3	4.42
Max		Max		Max		Max		113.3	4.46
Main Screen Diagonal		S. max		V. max		C. max		Condition	
mm	inch	mm	inch	mm	inch	mm	inch	mm	inch
Avg		Avg		Avg		Avg		198.6	7.82
Max		Max		Max		Max		201.6	7.94
Main Screen Diagonal		S. max		V. max		C. max		Condition	
mm	inch	mm	inch	mm	inch	mm	inch	mm	inch
Avg		Avg		Avg		Avg		210.1	8.27
Max		Max		Max		Max		210.1	8.27

Operating Temperature: -20~+70°C  
Storage Temperature: -30~+80°C