



**SPECIFICATION
FOR
LCD MODULE**

Customer : _____
Product Model: YH097LH3001
Sample code: _____

Designed by	Checked by	Approved by

Final Approval by Customer

<input type="checkbox"/> LCM Machinery OK Checked By _____ <input type="checkbox"/> LCM Display OK Checked By _____	<input type="checkbox"/> LCM OK <input type="checkbox"/> NG , Problem survey: Approved By _____
--	---

※The specification of "TBD" should refer to the measured value of sample . If there is difference between the design specification and measured value, we naturally shall negotiate and agree to solution with customer.



宇华国际科技有限公司
YuHua INT,L Technology Co., LIMITED

Revision History

Version	Date	Modified Page	Description
0.1	2013.09.04	-	initial release
0.2	2014.02.11		update



Table of Contents

	Page
1. General Feature.....	4
2. Absolute Maximum Ratings.....	5
3. Pixel Format Image.....	6
4. Optical Characteristics.....	7
5. Backlight Characteristics	10
6. Electrical Characteristics.....	11
7. Interface Timings.....	15
8. Power Consumption.....	16
9. Power ON/OFF Sequence.....	17
10. Mechanical Characteristics.....	18
11. Package Specification.....	20
12. Lot Mark.....	20
13. General Precaution.....	20



宇华国际科技有限公司

YuHua INT,L Technology Co., LIMITED

1 General Descriptions

1.1 Introduction

The P097SNX1C R0 is a Color Active Matrix Thin Film Transistor (TFT) Liquid Crystal Display (LCD) panel, which used amorphous Silicon TFT as a switching device. It is composed of a TFT LCD panel, a timing controller, column driver, and row driver circuit. This TFT LCD has a 9.7-inch (diagonally measured) active display area with XGA resolution (1024 horizontal by 768 vertical pixel array).

1.2 Features

- 9.7" TFT LCD Panel
- LED Backlight System
- Supports XGA (1024X768 pixels) Resolution
- Compatible with RoHS Standard

1.3 Product Summary

Item	Specification	Unit
Screen Diagonal	9.676	Inch
Active area	196.608 x 147.456	mm
Pixels (HxV)	1024 x 768	-
Pixel Pitch	0.192 (H) x 0.192 (V)	mm
Pixel Arrangement	R.G.B. Vertical Stripe	-
Display Mode	Normally Black	-
Contrast Ratio	(900) (Typ.)	-
Response Time	(20) (Typ.)	ms
Input Voltage	3.3V	V
Power Consumption (White Pattern, (60Hz, VDD=3.3V, B/L Power = 2.38W))	(3.36) Max.	W
Interface	LVDS	
Outline dimension (H x V)	205.81 (typ.)x 158.06 (typ.) x 2.9 (max.)	mm
Support Color	262,144	
Weight	250	g
Surface treatment	Glare, 3H	



宇华国际科技有限公司 YuHua INT,L Technology Co., LIMITED

1.4 Function Block Diagram

Figure 1 shows the functional block diagram of the LCD module

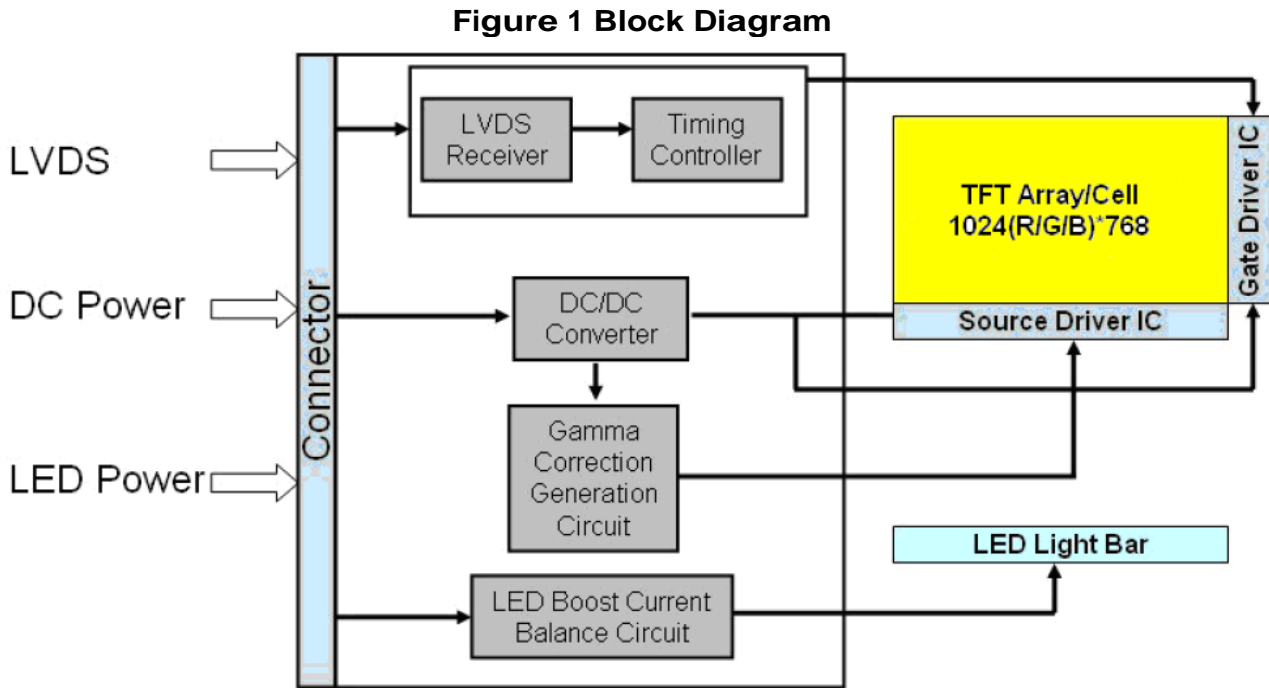

2. Absolute Maximum Ratings

Item	Symbol	Min.	Max.	Unit	Conditions
Logic Supply Voltage	VDD	3.0	3.6	V	TA=25°C
Operating Temperature	TOP	0	50	°C	
Operating Humidity	HOP	-	90	%RH	
Storage Temperature	TST	-20	60	°C	
Storage Humidity	HST	-	90	%RH	

Note: The module may be destroyed and not be recovered while the absolute maximum rating values of this product have been exceeded

Figure 2 Absolute Ratings of Environment of the LCD

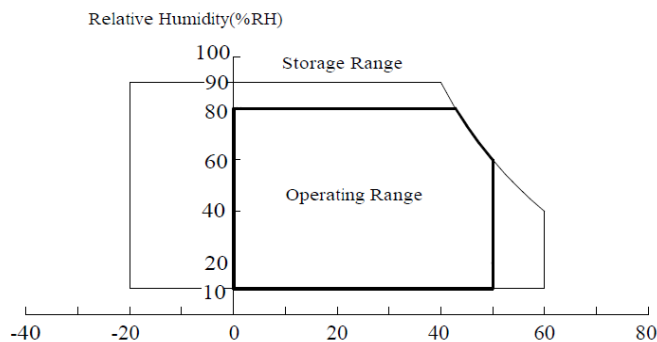



宇华国际科技有限公司

YuHua INT,L Technology Co., LIMITED

3. Pixel Format Image

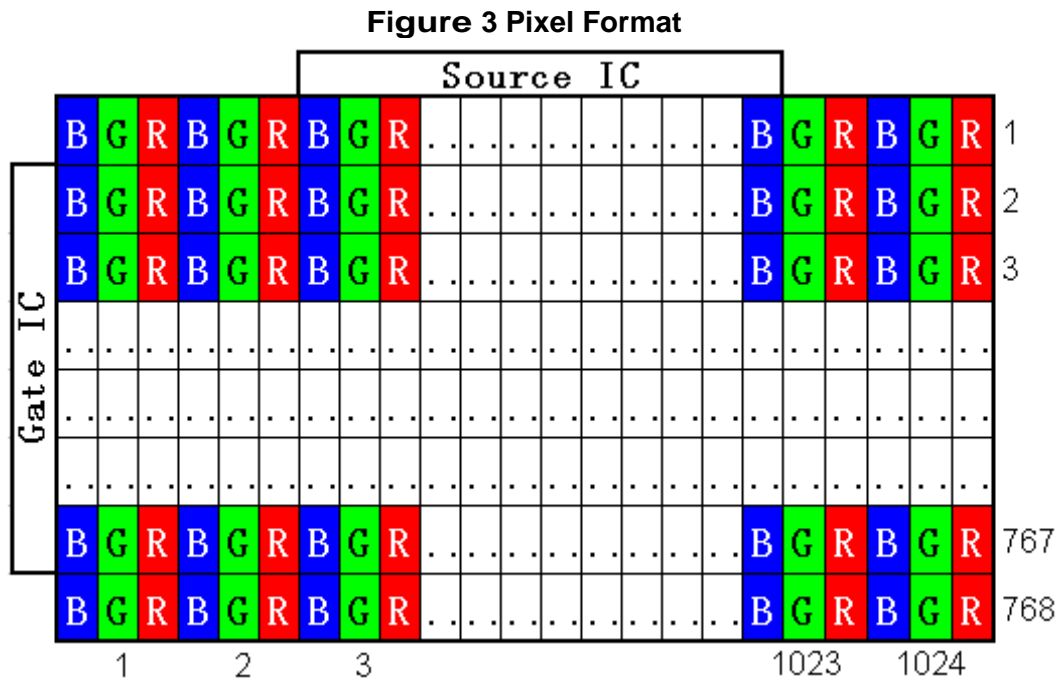

B+G+R dots=1 pixel



宇华国际科技有限公司

YuHua INT,L Technology Co., LIMITED

4. Optical Characteristics

The optical characteristics are the measured under stable conditions as following notes

Ite	Conditions		Min.	Typ.	Max.	Unit	Note
Viewing Angle (CR>10)	Horizontal	θ L	TBD	89	-	degree	(1),(2),(3)
		θ R	TBD	89	-		
	Vertical	θ T	TBD	89	-		
		θ B	TBD	89	-		
Contrast Ratio	Center		(700)	(900)	-	-	(1),(2),(3)
Response Time	Rising		-	-	-	ms	(1),(2),(4)
	Falling		-	-	-	ms	
	Rising + Falling		-	(20)	(25)	ms	
Color Chromaticity (CIE1931)	Red x	(Typ. -0.03)	(Typ. +0.03)	(0.601)	-	(1),(2)	
	Red y			(0.341)	-		
	Green x			(0.305)	-		
	Green y			(0.571)	-		
	Blue x			(0.150)	-		
	Blue y			(0.124)	-		
	White x			(0.288)	-		
	White y			(0.318)	-		
NTSC			-	50	-	-	
White Luminance			-	(350)	-	cd/m ²	(5)
Luminance Uniformity	9 Point		80	85	-	%	(6)

Note: (1)Measurement Setup

The LCD module should be stabilized at 25°C for 15 minutes to avoid abrupt temperature change during measuring. In order to stabilize the luminance, the measurement should be executed after lighting backlight for 15 minutes in a windless room.



宇华国际科技有限公司 YuHua INT,L Technology Co., LIMITED

Figure 4 Measurement Setup

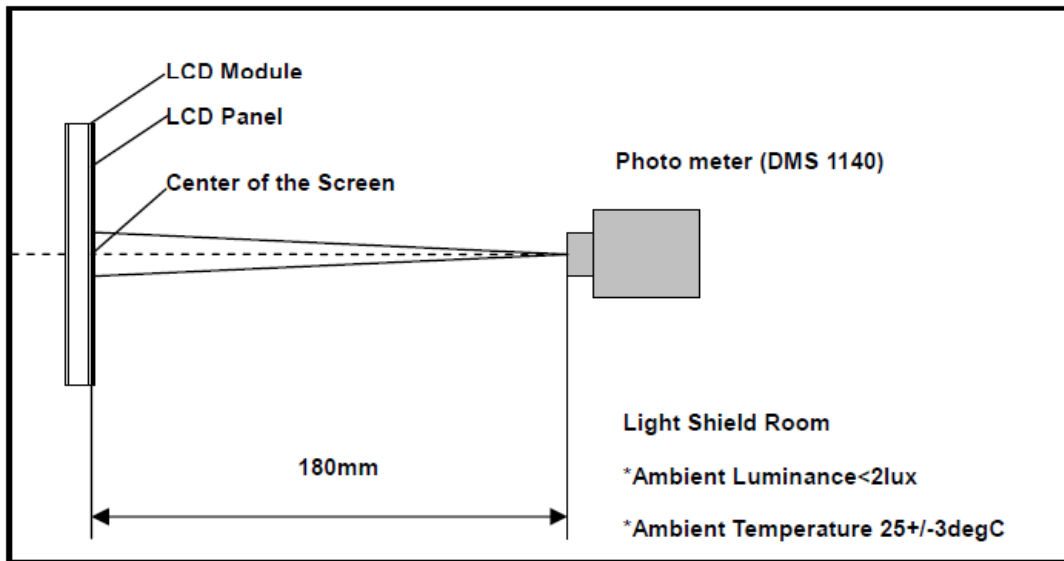

(2) Definition of Viewing Angle

Figure 5 Definition of Viewing Angle

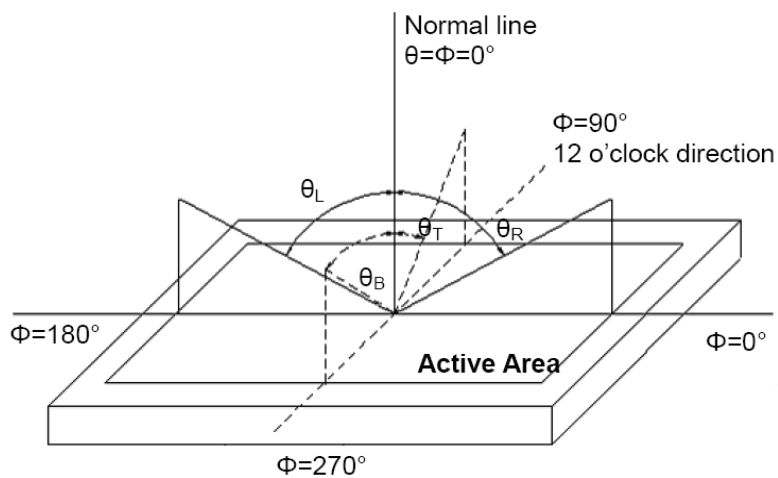

(3) Definition of Contrast Ratio (CR)

The contrast ratio can be calculated by the following expression

$$\text{Contrast Ratio (CR)} = L_{63} / L_0$$

L_{63} : Luminance of gray level 63, L_0 : Luminance of gray level 0



宇华国际科技有限公司

YuHua INT,L Technology Co., LIMITED

(4) Definition of Response Time (T_R , T_F)

Figure 6 Definition of Response Time

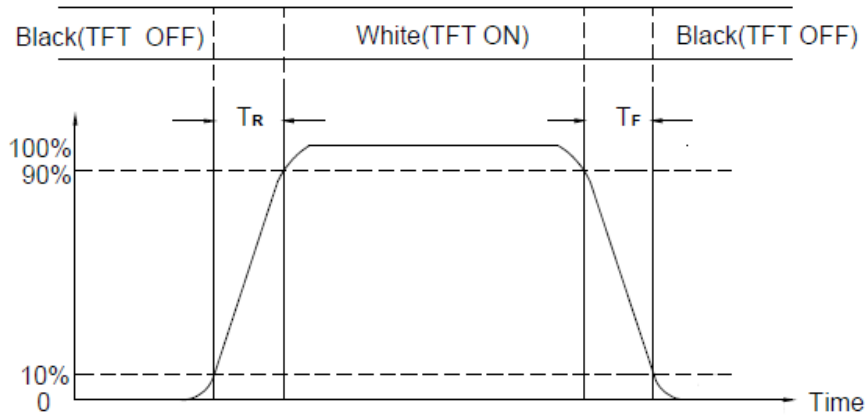

(5) Definition of Luminance White

Measure the luminance of gray level 63 at center point (Ref: Active area)



宇华国际科技有限公司

YuHua INT,L Technology Co., LIMITED

(6) Definition of Luminance Uniformity (Ref: Active area)

$$U (9 \text{ Points }) = \frac{\text{Min} (L1, L2, \dots L9)}{\text{Max} (L1, L2, \dots L9)}$$

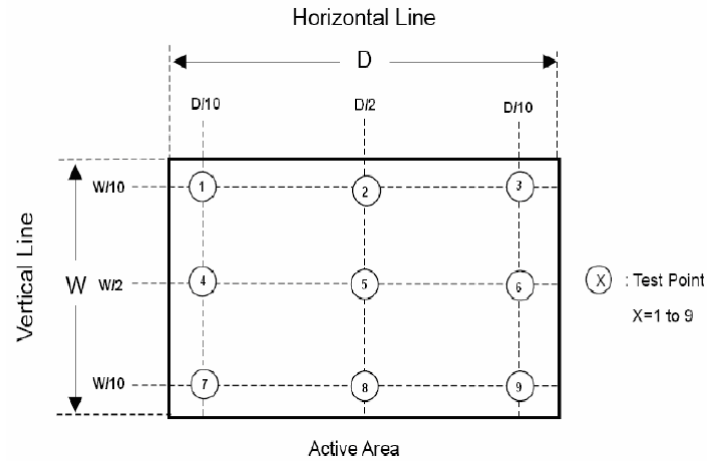



5. Backlight Characteristics

5.1 Parameter Guideline of LED Backlight

Table 4 Parameter Guideline of LED Backlight

Item	Symbol	Min.	Typ.	Max.	Units	Note	
LED Input Voltage	V_{LED}	18	19.8	21	V	(2)	
LED Power Consumption	P_{LED}	-	2.38	2.45	W	(2)	
LED Forward Voltage	V_F	3.0	3.3	3.4	V	(2)	
LED Forward Current	I_F	-	20	-	mA		
PWM Signal Voltage	V_{PWM_EN}	High	2.0	3.3	3.6		V
		Low	0	-	0.5		
LED Enable Voltage	V_{LED_EN}	High	2.0	3.3	3.6		V
		Low	0	-	0.5		
Input PWM Frequency	F_{PWM}	200	-	2000	Hz		
LED Life Time	LT		30000				
Duty Ratio	PWM	1	-	100	%		

Note (1) The LED life time define as the estimated time to 50% degradation of initial luminous.

Note(2) Operating temperature 25°C, humidity 55%.



宇华国际科技有限公司

YuHua INT,L Technology Co., LIMITED

6. Electrical Characteristics

6.1 Interface Connector

Table 5 Connector Name / Designation

Manufacturer	I-PEX
Type / Part Number	20525-030E-02
Mating Receptacle/Part Number	20525-030T

Table 6 Signal Pin Assignment

NO	Symbol	Descriptio
1	VSS	Ground
2	VCCS	Power Supply, 3.3V(typ)
3	VCCS	Power Supply, 3.3V(typ)
4	VEDID	EDID power, 3.3V(typ)
5	BIST	No connection
6	CLKEDID	EDID Clock Input
7	DATAEDID	EDID Data Input
8	Rxin0-	LVDS differential data input
9	Rxin0+	LVDS differential data input
10	VSS	Ground
11	Rxin1-	LVDS differential data input
12	Rxin1+	LVDS differential data input
13	VSS	Ground
14	Rxin2-	LVDS differential data input
15	Rxin2+	LVDS differential data input
16	VSS	Ground
17	RxCLK-	LVDS differential clock input
18	RxCLK+	LVDS differential clock input
19	VSS	Ground
20	NC	No connection
21	Vdc	LED Annode(Positive)
22	Vdc	LED Annode(Positive)
23	NC	No connection
24	Vdc1	LED Cathode1(Negative)
25	Vdc2	LED Cathode2(Negative)
26	Vdc3	LED Cathode3(Negative)



宇华国际科技有限公司

YuHua INT,L Technology Co., LIMITED

27	Vdc4	LED Cathode4(Negative)
28	Vdc5	LED Cathode5(Negative)
29	Vdc6	LED Cathode6(Negative)
30	NC	No connection

6.2 LVDS Receiver

6.2.1 Signal Electrical Characteristics For LVDS Receiver

The built-in LVDS receiver is compatible with (ANSI/TIA/TIA-644) standard.

Table 7 Signal Pin Assignment

Parameter	Symbol	Min.	Typ.	Max.	Unit	Note
LVDS differential input Voltage Voltage input Threshold	VID	200	-	600	mV	
LVDS common input Voltage	VCM	1.125	1.2	1.375	V	
Logic High input Voltage	VIH	-	-	+0.1	V	VCM=1.2V
Logic Low input Voltage	VIL	-0.1	-	-	V	

Figure 7 Voltage Definition

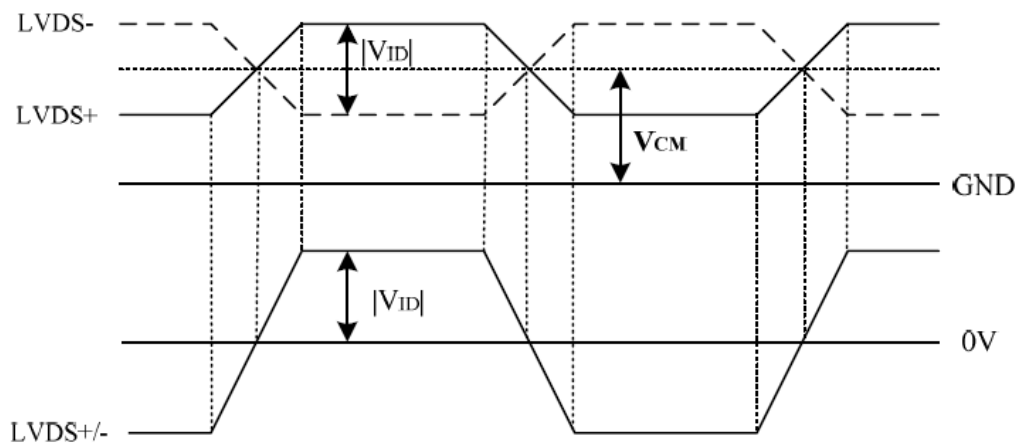



Figure 8 Measurement System

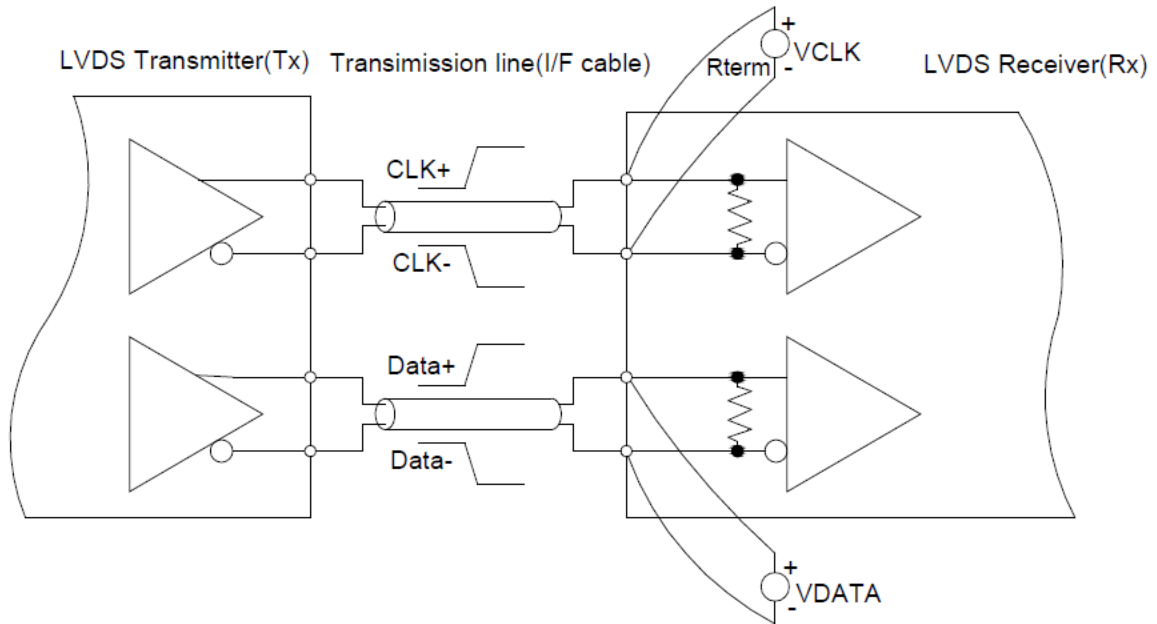
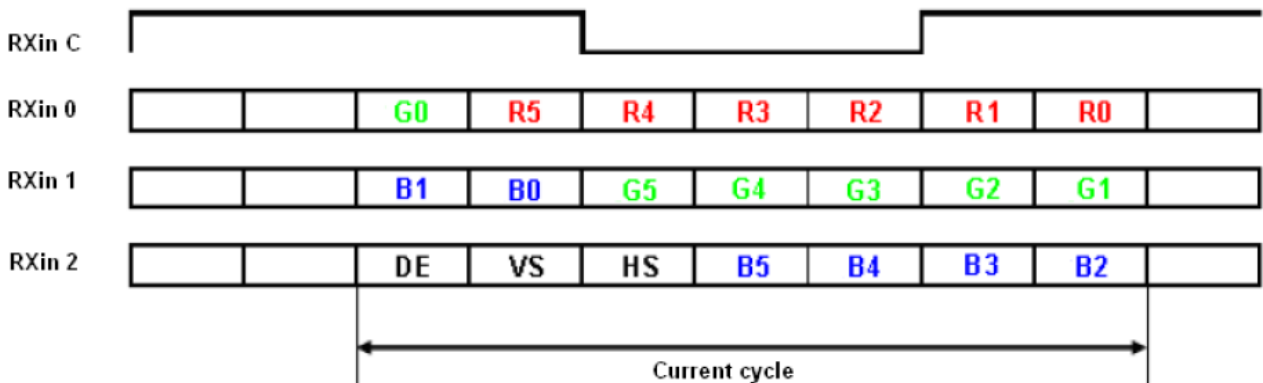

Figure 9 Data Mapping



6.2.2 LVDS Receiver Internal Circuit

LVDS receiver. The LCD module equips termination resistors for LVDS links.



Figure 10 LVDS Receiver Internal Circuit

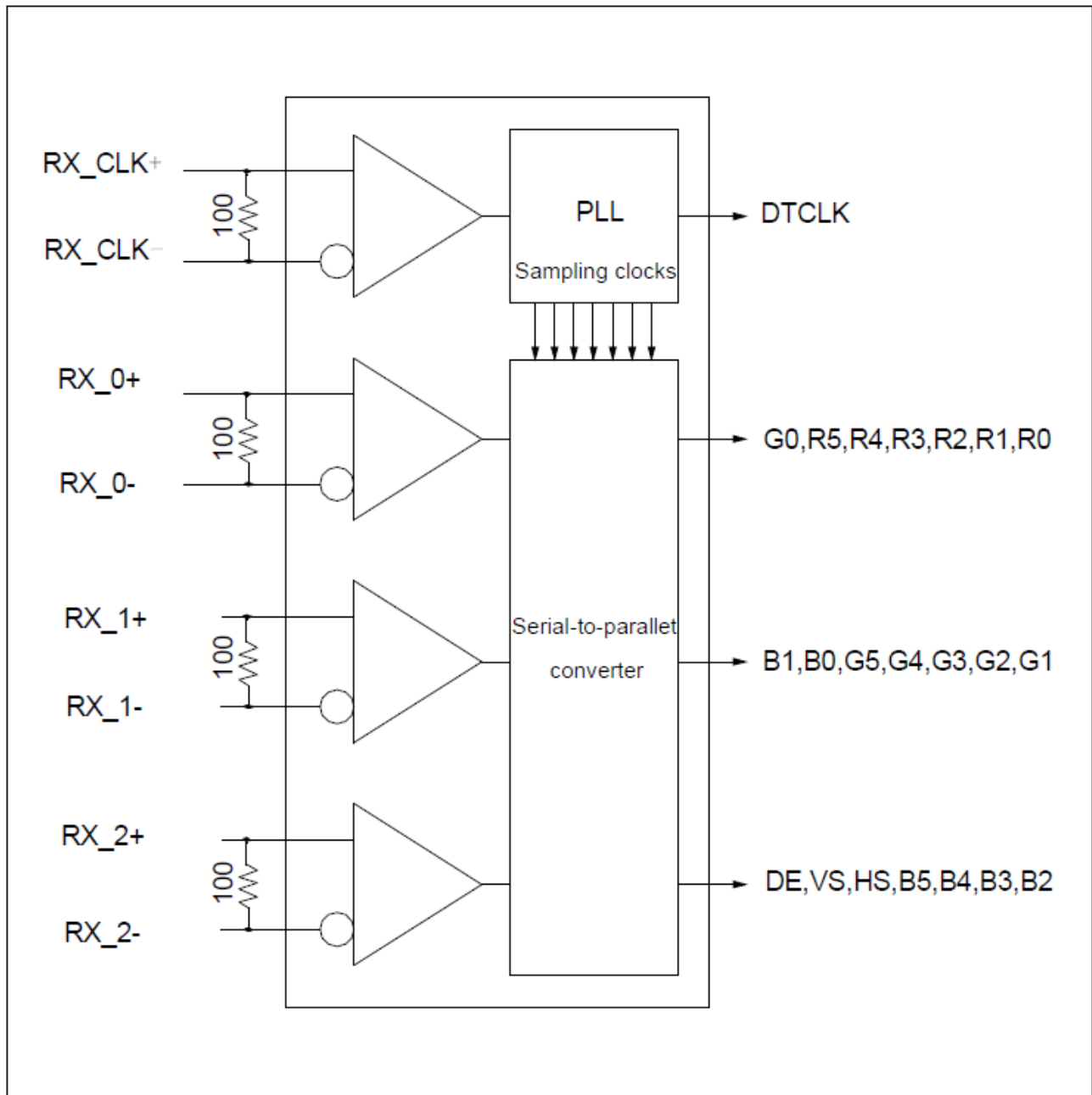



宇华国际科技有限公司

YuHua INT,L Technology Co., LIMITED

7. Interface Timings

7.1 Timing Characteristics

Table 8 Interface Timings

Parameter	Symbol	Unit	Min.	Typ.	Max.
Frame Rate	--	Hz	-	60	-
Frame Period`	t1	line	-	806	-
Vertical Display Time	t2	line	-	768	-
Vertical Blanking Time	t3	line	-	38	-
1 Line Scanning Time	t4	clock	-	1344	-
Horizontal Display Time	t5	clock	-	1024	-
Horizontal Blanking Time	t6	clock	-	320	-
Clock Rate	t7	MHz	-	65	-

Figure 11 Timing Characteristics

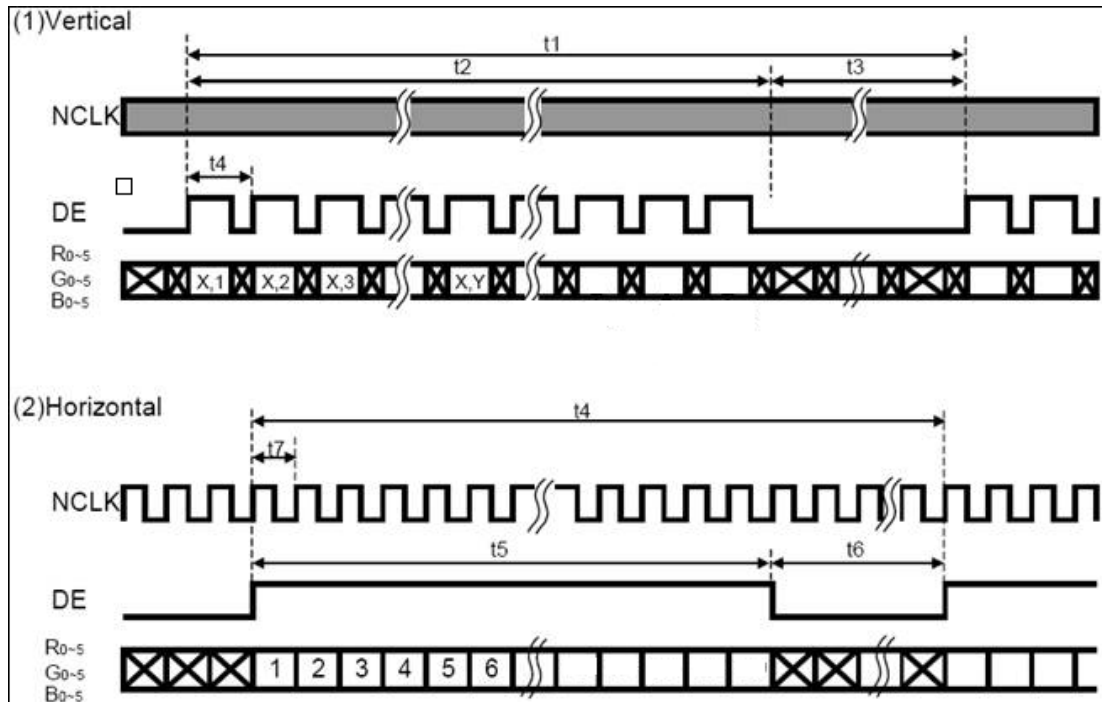



8. Power Consumption

Input power specification are as followings.

Table 9 Power Consumption

TBD

Figure 12 VDD rising time

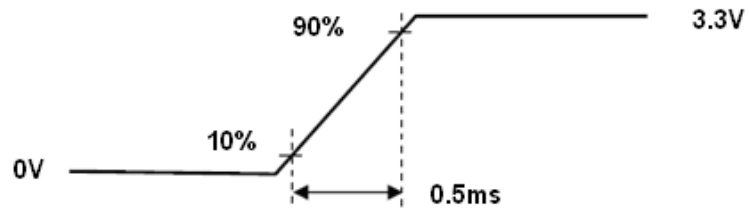

VDD rising time



9. Power ON/OFF Sequence

VDD power on/off sequence is as follows. Interface signals are also shown in the chart. Signals from any system shall be Hi-resistance state or low when VDD is off.

Figure 13 Power Sequence

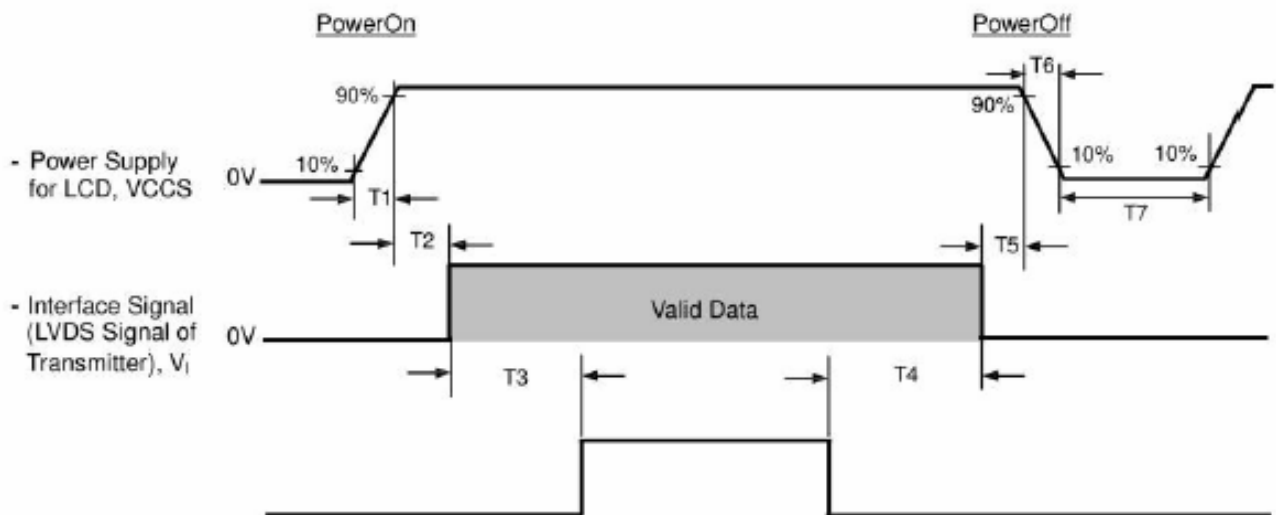

Table 10 Power Sequencing Requirements

Item	Unit	Min	Typ.	Max
T1	ms	0.5	-	10
T2	ms	0	20	50
T3	ms	200	-	-
T4	ms	200	-	-
T5	ms	0.5	20	50
6	ms	1	-	20
7	ms	500	-	-



宇华国际科技有限公司

YuHua INT,L Technology Co., LIMITED

10. Mechanical Characteristics

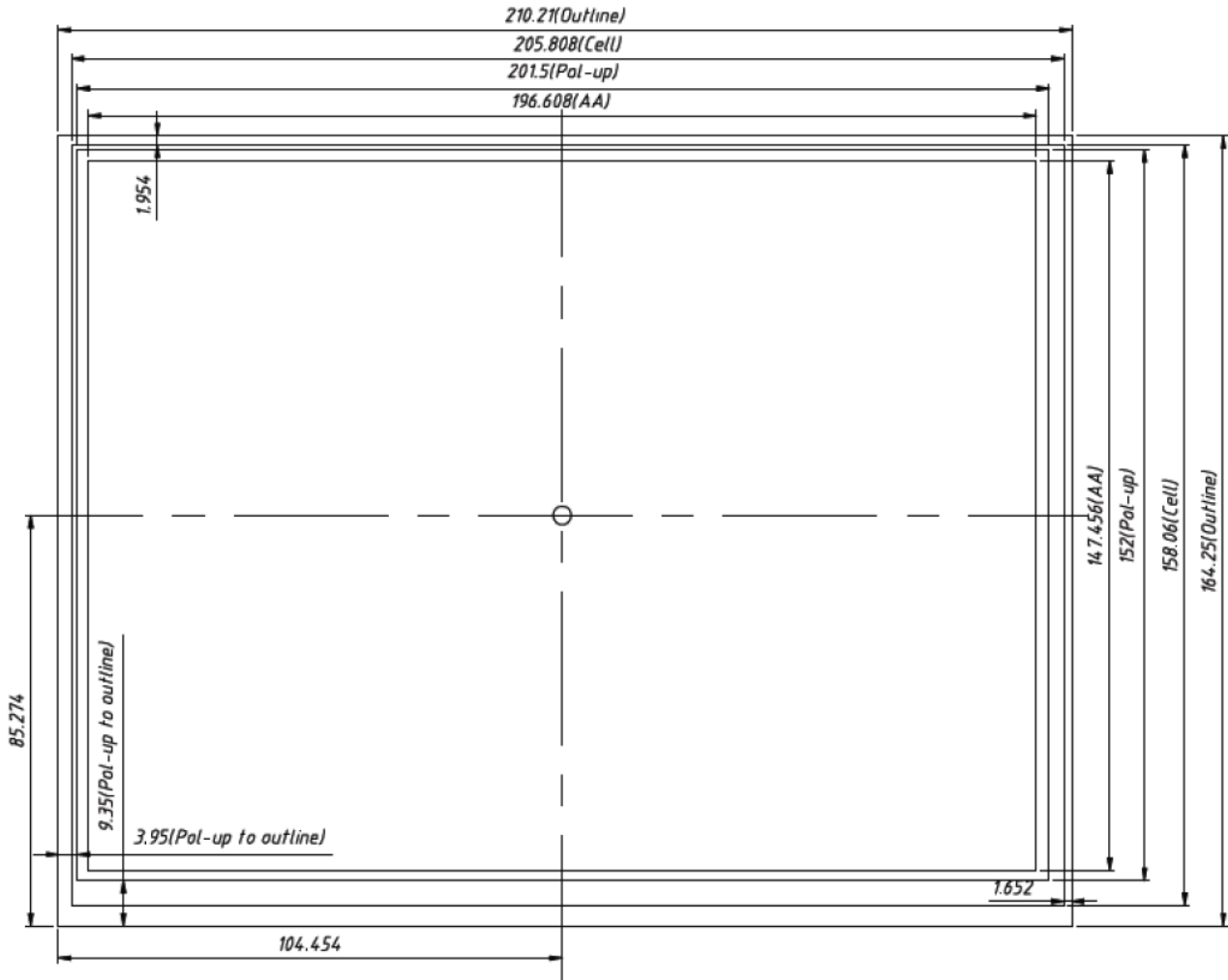



宇华国际科技有限公司
YuHua INT,L Technology Co., LIMITED

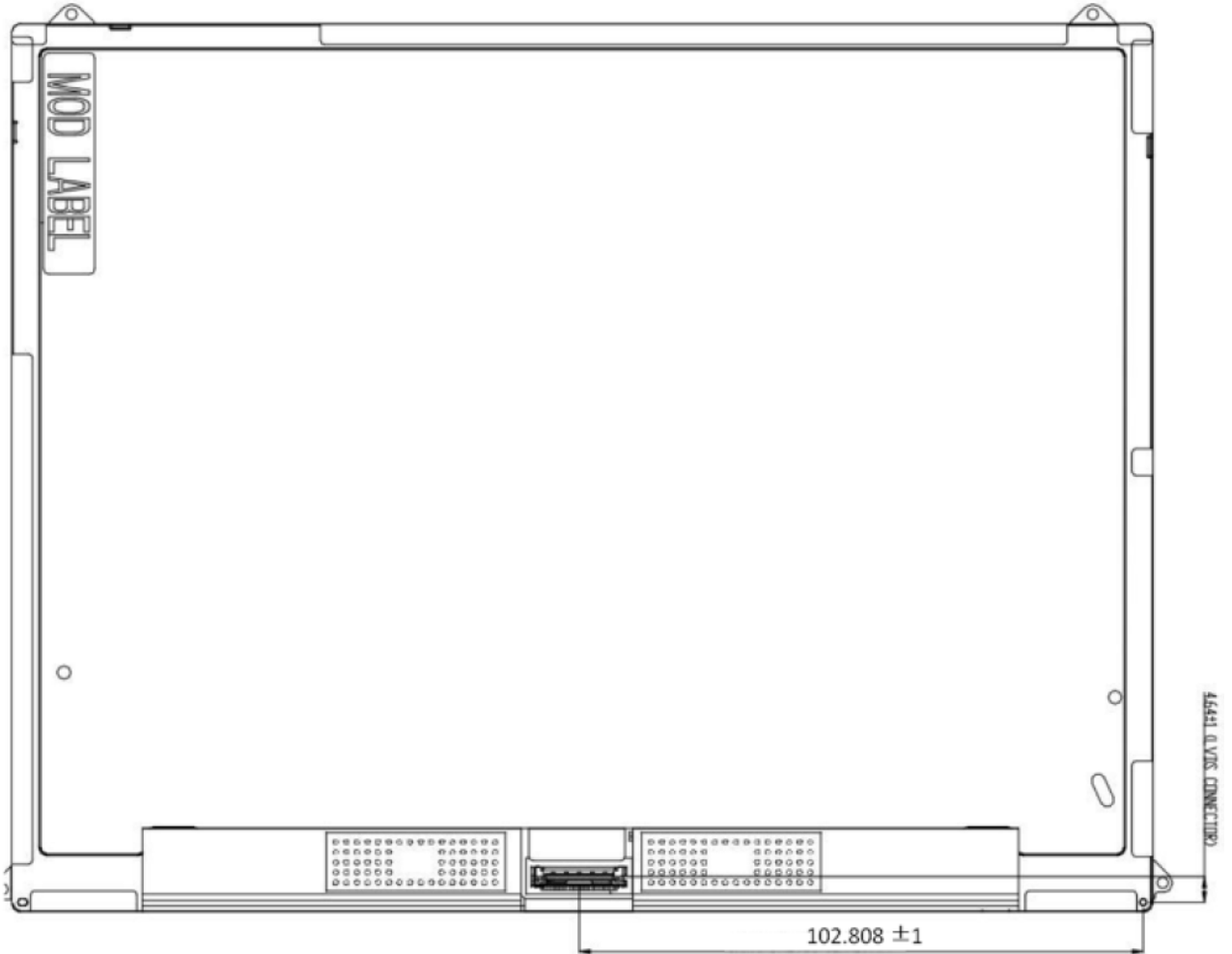



宇华国际科技有限公司

YuHua INT,L Technology Co., LIMITED

11. Package Specification

TBD

12. Lot Mark

TBD

13. General Precaution

13.1 Use Restriction

This product is not authorized for use in life supporting systems, aircraft navigation control systems, military systems and any other application where performance failure could be life-threatening or otherwise catastrophic.

13.2 Handling Precaution

- 1) Please mount LCD module by using mounting holes arranged in four corners tightly.
- 2) Do not disassemble or modify the module. It may damage sensitive parts inside LCD module, and may cause scratches or dust on the display. PVO does not warrant the module, if customers disassemble or modify the module.
- 3) If LCD panel is broken and liquid crystal spills out, do not ingest or inhale liquid crystal, and do not contact liquid crystal with skin. If liquid crystal contacts mouth or eyes, rinse out with water immediately. If liquid crystal contacts skin or cloths, wash it off immediately with alcohol and Rinse thoroughly with water.
- 4) Disconnect power supply before handling LCD module.
- 5) Refrain from strong mechanical shock and /or any force to the module.
- 6) Do not exceed the absolute maximum rating values, such as the supply voltage variation, input voltage variation, variation in parts' parameters, environmental temperature; etc otherwise LCD module may be damaged. It's recommended employing protection circuit for power supply.
- 7) Do not touch, push or rub the polarizer with anything harder than HB pencil lead. And please do not rub with dust clothes with chemical treatment. Do not touch the surface of polarizer for bare hand or greasy cloth. (Some cosmetics are detrimental to the polarizer.)
- 8) When the surface is dusty, please wipe gently with absorbent cotton or other soft Material. When cleaning the adhesives, please use absorbent cotton wetted with a little petroleum benzene. Normal-hexane is recommended for cleaning the adhesives used to attach front/ rear polarizer. Do not use acetone, toluene and alcohol because they cause chemical damage to the polarizer.
- 9) Wipe off saliva or water drops as soon as possible. Their long time contact with polarizer causes deformations and color fading.
- 10) Protection film must be removed very slowly from the surface of LCD module to prevent from electrostatic occurrence.
- 11) Because LCD module uses CMOS-IC on circuit board and TFT-LCD panel, it is very weak to electrostatic discharge, Please be careful with electrostatic discharge. Persons who handle the module should be grounded through adequate methods.
- 12) Do not adjust the variable resistor located on the module.



宇华国际科技有限公司

YuHua INT,L Technology Co., LIMITED

13.3 Storage Precaution

- 1) Please do not leave LCD module in the environment of high humidity and high temperature for a long time.
- 2) The module shall not be exposed under strong light such as direct sunlight. Otherwise, display characteristics may be changed.
- 3) The module should be stored in a dark place. It is prohibited to apply sunlight or fluorescent light in storage.

13.4 Operation Precaution

- 1) Do not connect or disconnect the module in the "Power On" condition.
- 2) Power supply should always be turned on/off by 3.5 "Power on/off sequence".
- 3) Module has high frequency circuits. Sufficient suppression to the electromagnetic interference should be done by system manufacturers. Grounding and shielding methods may be important to minimize the interference.
- 4) After installation of the TFT Module into an enclosure, do not twist nor bend the TFT Module even momentary. At designing the enclosure, it should be taken into consideration that no bending/twisting forces are applied to the TFT Module from outside. Otherwise the TFT Module may be damaged.

13.5 Others

- 1) Ultra-violet ray filter is necessary for outdoor operation.
- 2) Avoid condensation of water which may result in improper operation or disconnection of electrode.
- 3) If the module keeps displaying the same pattern for a long period of time, the image may be "Sticked" to the screen.
- 4) This module has its circuitry PCB on the rear side and should be handled carefully in order not to be stressed.

13.6 Disposal

When disposing LCD module, obey the local environmental regulations.