



**SPECIFICATION
FOR
LCD MODULE**

Customer : _____
Product Model: YH101BS5001 V03
Sample code: _____

Designed by	Checked by	Approved by

Final Approval by Customer

<input type="checkbox"/> LCM Machinery OK Checked By _____ <input type="checkbox"/> LCM Display OK Checked By _____	<input type="checkbox"/> LCM OK <input type="checkbox"/> NG , Problem survey: Approved By _____
--	---

※The specification of "TBD" should refer to the measured value of sample . If there is difference between the design specification and measured value, we naturally shall negotiate and agree to solution with customer.



1. PHYSICAL DATA

Item	Contents	Unit
LCD type	TFT TRANSMISSIVE	---
Viewing direction	ALL	o'clock
Module size (W×H×T)	235 × 143 × 5.1	mm ³
Active area(W×H)	222.72×125.28	mm ²
Number of dots(W×H)	1024(RGB) × 600	dots
Pixel Pitch(H×V)	0.2175×0.2088	mm
Driver IC	EK79001	---
Colors	16.7M	---
Backlight Type	27white leds 9.6V 180mA	---
Interface Type	RGB	---

2. BLOCK DIAGRAM

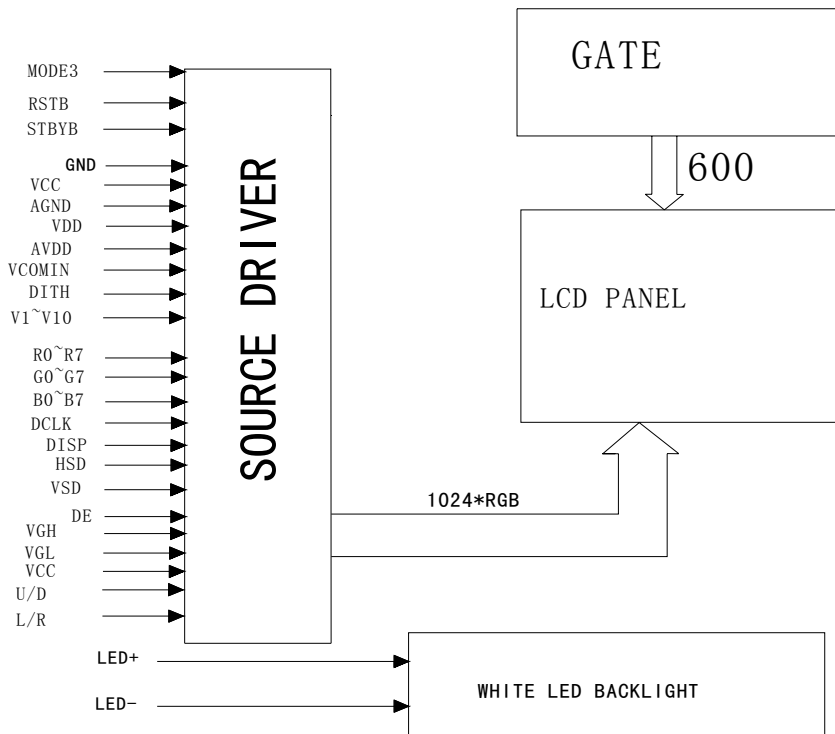



3. Mechanical Dimension

NO.	Pin name	NO.	Pin name
1	A1 (NC)	33	R2
2	A2 (NC)	34	R1
3	K1 (NC)	35	R0
4	K2 (NC)	36	GND
5	GND	37	DCLK
6	VCOM	38	GND
7	DVDD	39	L/R
8	MODE	40	UD
9	DE	41	VGH
10	VS	42	VGL
11	HS	43	AVDD
12	B7	44	RESET
13	B6	45	NC
14	B5	46	VCOM
15	B4	47	DITHB
16	B3	48	GND
17	B2	49	NC
18	B1	50	NC
19	B0		
20	G7		
21	G6		
22	G5		
23	G4		
24	G3		
25	G2		
26	G1		
27	G0		
28	R7		
29	R6		
30	R5		
31	R4		
32	R3		

LED 电路图

UNIT: mm	SCALE: NO SCALE	SIZE: A4
GENERAL TOLERANCE: ±0.2	Angle=1°	
DESIGNED: CZS	Date: 2019-4-22	PART NAME: MODULE DRAWING
CHECKED:	Date:	PROJECT NO.:
APPROVED:	Date:	PART NO.:
		SHEET: 1/1
		REV: A

* Unspecified Tolerances is: ±0.2

Note:	
LCD TYPE	10.1 inch TFT Transmissive
DISPLAY MODE	Normally black
VIEW DIRECTION	ALL
OPERATING TEMP.	-20° C ~ 80° C
STORAGE TEMP.	-20° C ~ 70° C
BACK LIGHT	42 White leds
BL voltage/current	9.6V / 180mA
ALL MATERIALS	MUST BE ROHS COMPLIANT



4. Pin Descriptions

Pin No.	Symbol	Functional
1	LED A	LED Anode
2	LED A	LED Anode
3	LED K	LED Cathode
4	LED K	LED Cathode
5	GND	Digital Ground
6	VCOM	For external VCOM DC input
7	DVDD	Digital Power
8	MODE	DE/SYNC mode select MODE=H: DE mode(normally pull high) MODE=L: HSD/VSD mode
9	DE	Data enable signal
10	VSYNC	Vertical sync input.Negative polarity
11	HSYNC	Horizontal sync input.Negative polarity
12~19	B7~B0	Blue data Input
20~27	G7~G0	Green data Input
28~35	R7~R0	Red data Input
36	GND	Digital Ground
37	DCLK	Clock input
38	GND	Digital Ground
39	L/R	Source right or left sequence control SHLR=H: right shift, Left → Right SHLR=L: left right, Right → Left
40	U/D	Gate up or down scan control UPDN=H: up shift, Down → Up UPDN=L: down shift, Up → Down
41	VGH	Positive Power for TFT
42	VGL	Negative Power for TFT
43	AVDD	Analog Power
44	RSTB	Global reset pin.Active low to enter reset state Suggest to connecting with an RC reset circuit for stability. Normally pull high. (RC circuit :R=10K Ω , C=1uF)
45	NC	Not connect
46	VCOM	For external VCOM DC input
47	DITHB	Dithering setting
48	GND	Digital Ground
49	NC	Not connect
50	NC	Not connect



5. OPERATION SPECIFICATION

5.1 Absolute maximum ratings

Parameter	Symbol	Min	Max	Unit
Power supply1	V _{DD}	-0.5	+3.96	V
Power supply2	A _{vdd}	-0.5	+13.85	V
Operating temperature	T _{OPR}	-10	50	°C
Storage temperature	T _{STG}	-20	60	°C

5.2 Input driver voltage

Parameter	Symbol	Value	Unit	Remarks
TFT Gate ON Voltage	V _{GH}	21	V	
TFT Gate Off Voltage	V _{GL}	-8	V	
TFT Common Electrode Voltage	V _{COM}	3.8	V	NOTE
Analog Power Supply Voltage	AVDD	10.8	V	

Note: Please adjust Vcom to make the flicker level be minimum

6. DC ELECTRICAL CHARACTERISTICS

Parameter	Symbol	Spec.			Unit	Condition
		Min.	Typ.	Max.		
Differential input high Threshold voltage	R _{XVTH}	-	-	+0.1	V	R _{XVCM} =1.2V
Differential input low threshold voltage	R _{XVTL}	-0.1	-	-	V	
Input voltage range (singled-end)	R _{XVIN}	0	-	VDD-1.2+ V _{ID} /2	V	-
Differential input common Mode voltage	R _{XVCM}	V _{ID} /2	-	VDD-1.2	V	-
Differential input voltage	V _{ID}	0.2	-	0.6	V	-
Differential input leakage Current	R _{VXILZ}	-10	-	+10	μA	-
LVDS Digital Operating Current	I _{ddlvs}	-	15	30	mA	Fclk=65MHz, VDD=3.3V
LVDS Digital Stand-by Current	I _{stlvs}	-	10	50	μA	Clock & all Functions are stopped



HV mode :

Horizontal timing

Parameter	Symbol	Spec.			Unit
		Min.	Typ.	Max.	
DCLK Frequency	fclk	44.9	51.2	63	MHz
Horizontal Display Area	thd	1024			DCLK
HSD Period	th	1200	1344	1400	DCLK
HSD Pulse Width	thpw	1	-	140	DCLK
HSD Back Porch	thbp	160			DCLK
HSD Front Porch	thfp	16	160	216	DCLK

Vertical Timing

Parameter	Symbol	Spec.			Unit
		Min.	Typ.	Max.	
Vertical Display Area	tvd	600			T _H
VSD Period	tv	624	635	750	T _H
VSD Pulse Width	tvpw	1	-	20	T _H
VSD Back Porch	tvbp	23			T _H
VSD Front Porch	tvfp	1	12	127	T _H

8. Data input format for RGB

DE mode

DE mode					
Parameter	Symbol	Value			Unit
		Min.	Typ.	Max.	
DCLK frequency @Frame rate=60hz	fclk	40.8	51.2	67.2	Mhz
Horizontal display area	thd	1024			DCLK
HSYNC period time	th	1114	1344	1400	DCLK
HSYNC blanking	thb+thfp	90	320	376	DCLK
Vertical display area	tvd	600			H
VSYNC period time	tv	610	635	800	H
VSYNC blanking	tvb+tvfp	10	35	200	H



宇华国际科技有限公司

YuHua INT,L Technology Co., LIMITED

HV mode(1)

HV mode Horizontal input timing						
Parameter	Symbol	Value			Unit	
Horizontal display area	thd	1024			DCLK	
DCLK frequency@ Frame rate=60hz	fclk	Min.	Typ.	Max.	Mhz	
		44.9	51.2	63		
1 Horizontal Line	th	1200	1344	1400	DCLK	
HSYNC pulse width	thpw	Min.	1			
		Typ.	—			
		Max.	140			
HSYNC back porch	thbp	160	160	160		
HSYNC front porch	thfp	16	160	216		

HV mode(2)

Vertical input timing						
Parameter	Symbol	Value			Unit	
		Min.	Typ.	Max.		
Vertical display area	tvd	600			H	
VSYNC period time	tv	624	635	750	H	
VSYNC pulse width	tvpw	1	—	20	H	
VSYNC back porch	tvb	23	23	23	H	
VSYNC front porch	tvfp	1	12	127	H	



9. Backlight Characteristic

Item	Symbol	Min	Typical	Max	Unit
LED module Forward voltage	V_{LED}	--	9.6	--	V
LED module current	I_{LED}	--	280	--	mA
L/G Surface Luminance ★1	L_s	--	400	--	mc/d
LCM Surface brightness uniform ★2	L_D	80	--	--	%

★ 1 Test condition is:

- (a) Center point on active area.
- (b) Best Contrast.

★2 Uniform measure condition:

- (1) Measure 9 point. Measure location show below;
- (2) Uniform = (Min. brightness / Max. brightness) * 100%
- (3) Best Contrast.

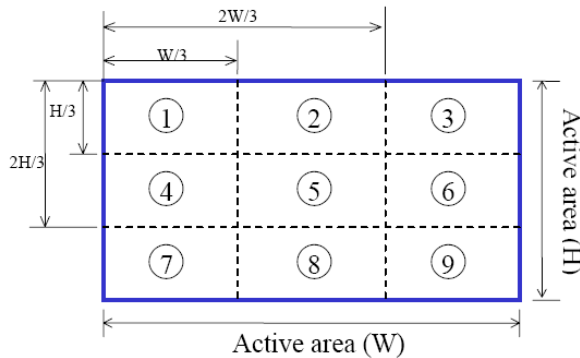

10. Electro-optical Characteristics

Parameter	Symbol	Condition	Min	Typ	Max	Unit	Remark
Viewing angle range	Hor.	$\phi 3$	$CR \geq 10$	70		Deg	
		$\phi 9$		70	Deg		
	Ver.	$\phi 12$		60	Deg		
		$\phi 6$		70	Deg		
Color gamut (C light)			50		%		
Luminance Contrast ratio	T (%)	$\phi 0^\circ$		600			
Response Time	T_{RT}	Temp=25° C		8		ms	



11. Reliability

11.1 Mtbf

The LCD module shall be designed to meet a minimum MTBF value of 50000 hours with normal

11.2 Test condition

N O.	ITEM	CONDITION	CRITERION
1	High Temperature Non-Operating Test	80°C*12Hrs	NoDefectOfOperational Function In Room Temperature Are Allowable
2	Low Temperature Non-Operating Test	-20°C*12Hrs	
3	High Temperature/Humidity Non Operating Test	60°C*75%RH*120Hrs	
4	High Temperature Operating Test	70°C*120Hrs	
5	Low Temperature Operating Test	-20°C*120Hrs	
6	Thermal Shock Test	-10 °C (30Min) - 50 °C (30Min) *10CYCLES	

Notes:

1. Judgments should be made after exposure in room temperature for two hours.
2. The distill water is used for the high temperature/humidity test.
3. The sample above is individually for every reliability tests condition.

12. Inspection standards

1.AQL(Acceptable Quality Level

AQL of major and minor defect.

	MAJOR DEFECT	MINOR DEFECT
AQL	0.65	1.5

2. Basic conditions for inspection

The LCM face to us, in normal environment, the lux is 1000 ± 200 . (Darkroom's lux: 100 ± 50), About an angle of incidence 30, a distance of 30 cm with an angle of 45 degree to check the products without uncovering the film!

(As shown below)

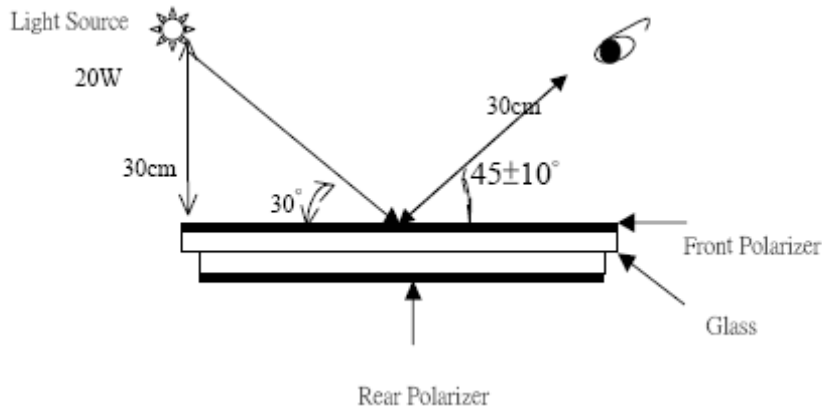

3. Inspection item and criteria

3.1 Visual inspection criterion in immobility

3.1.1 LCD appearance defect(View area)

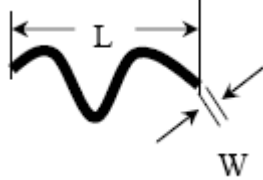
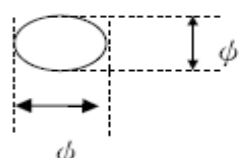
NO	Defect item	Criteria		Remark
		Specification	Allowable	
1	Fiber、glass cratch、polarizer scratch/folded (minor defect)	$W \leq 0.03\text{mm}$	disregard	note1:L: Length, W: Width note2: disregard if out of AA 
		$0.03\text{mm} < W \leq 0.05\text{mm};$ $L \leq 3.0\text{mm}$	2	
		$0.05\text{mm} < W \leq 0.1\text{mm};$ $L \leq 3.0\text{mm}$	1	
		$W > 0.1\text{mm}; L > 3.0\text{mm}$	0	
2	Polarizer bubble、 concave and convex (minor defect)	$\phi \leq 0.2\text{mm}$	disregard	note1: $\phi = (L+W)/2$, L:Length, W :Width note2:disregard if out of AA
		$0.2\text{mm} < \phi \leq 0.3\text{mm}$	2	
		$0.3\text{mm} < \phi \leq 0.5\text{mm}$	1	
		$0.5\text{mm} < \phi$	0	
3	Black dots、dirty dots、 impurities、eye winker (minor defect)	$\phi \leq 0.15\text{mm}$	disregard	note2:disregard if out of AA 
		$0.15\text{mm} < \phi \leq 0.25\text{mm}$	2	
		$0.25\text{mm} < \phi \leq 0.3\text{mm}$	1	
		$0.3\text{mm} < \phi$	0	
4	Polarizer prick (minor defect)	$\phi \leq 0.1\text{mm}$	disregard	note1: $\phi = (L+W)/2$, L=Length, W=Width note2:the distance between two dots>5mm
		$0.1\text{mm} < \phi \leq 0.25\text{mm}$	3	
		$\phi > 0.25\text{mm}$	0	

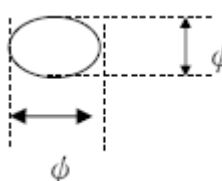
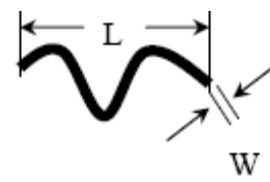

3.2Electrical criteria

NO	Defect item	Criteria	Remark	
1	No display (major defect)	No display 【Reject】		
2	Missing line (major defect)	Missing line 【Reject】		
3	Seg-com light and dark (major defect)	Seg-com light and dark 【Reject】	ND filter 2% test	
4	No display in immobility (major defect)	No display in immobility 【Reject】		
5	Flicker of Pattern (major defect)	Flicker of Pattern 【Reject】		
6	Mura (major defect)	ND filter 2%test		
7	Over current (major defect)	Over current 【Reject】		
8	Voltage out of specification (major defect)	Voltage out of specification 【Reject】		
9	Pattern blur, error code (major defect)	Pattern blur, error code 【Reject】		
10	Dark light, Flicker (major defect)	Dark light, Flicker 【Reject】		
11	Black/white dots 、 Dirty dots、 eye winker (major defect)	Specification	Allowable	Note1:disregard if out of AA 
		$\phi \leq 0.15\text{mm}$	disregard	
		$0.15\text{mm} < \phi \leq 0.25\text{mm}$	2	
		$0.25\text{mm} < \phi \leq 0.3\text{mm}$	1	
		$0.3\text{mm} < \phi$	0	
12	Fiber、glass crutch、Polarizer scratch/folded (major defect)	$W \leq 0.03\text{mm}$	disregard	Note1:L: Length, W: Width Note2: disregard if out of AA 
		$0.03\text{mm} < W \leq 0.05\text{mm}$ $L \leq 3.0\text{mm}$	2	
		$0.05\text{mm} < W \leq 0.1\text{mm}$ $L \leq 3.0\text{mm}$	1	
		$W > 0.1\text{mm}; L > 3.0\text{mm}$	0	



13.Precautions for using LCD modules.

13.1 Safety

- (1)Do not swallow any liquid crystal ,even if there is no proof that liquid crystal is poisonous.
- (2)If the LCD panel breaks, be careful not to get liquid crystal to touch your skin.
- (3)If skin is exposed to liquid crystal, wash the area thoroughly with alcohol or soap.

13.2 Storage Conditions

- (4)Store the panel or module in a dark place where the temperature is $23 \pm 5^{\circ}\text{C}$ and the humidity is below $45 \pm 20\%RH$.
- (5)Store in anti-static electricity container.
- (6)Store in clean environment, free from dust, active gas, and solvent.
- (7)Do not place the module near organics solvents or corrosive gases.
- (8))Do not crush, shake, or jolt the module.

13.3Handling Precautions

- (9)Avoid static electricity, which can damage the CMOS LSI.
- (10)The polarizing plate of the display is very fragile, please handle if very carefully.
- (11)Do not give external shock.
- (12)DO not apply excessive force on the surface.
- (13)Bo not wipe the polarizing plate with a dry cloth, as it may easily scratch the surface of plate.
- (14)Do not use ketonics solvent & Aromatic solvent, use with a soft cloth soaked with a cleaning naphtha solvent.
- (15)Do not operate it above the absolute maximum rating.
- (16)Do not remove the panel or frame from the module.

13.4 Warranty

The period is within twelve months since the date of shipping out under normal using and storage conditions.