



**SPECIFICATION
FOR
LCD MODULE**

Customer : _____

Product Model: YH101MF4002

Sample code: _____

Designed by	Checked by	Approved by

Final Approval by Customer

<input type="checkbox"/> LCM Machinery OK Checked By _____ <input type="checkbox"/> LCM Display OK Checked By _____	<input type="checkbox"/> LCM OK <input type="checkbox"/> NG , Problem survey: Approved By _____
--	---

※The specification of "TBD" should refer to the measured value of sample . If there is difference between the design specification and measured value, we naturally shall negotiate and agree to solution with customer.



Contents

1. General Specifications	1
2. Pin Assignment	2
3. Operation Specifications	4
3.1. Absolute Maximum Ratings	4
3.1.1. Current Consumption.....	4
3.2. Typical Operation Conditions	5
3.3. Power Sequence.....	6
3.4. Timing Characteristics	7
3.4.1. AC Electrical Characteristics.....	7
3.4.2. HS Transmission	7
3.4.3. DC Electrical Characteristics.....	8
3.4.4. Timing Table	9
3.4.5. Data Input Format For Mipi	9
4. Optical Specifications	10
5. Reliability Test Items	13
6. General Precautions	14
6.1. Safety	14
6.2. Handling	14
6.3. Static Electricity.....	14
6.4. Storage	14
6.5. Cleaning.....	14
7. Mechanical Drawing	15



1. General Specifications

No.	Item	Specification	Remark
1	LCD size	10.1 inch(Diagonal)	
2	Driver element	a-Si TFT active matrix	
3	Resolution	1200 × 3(RGB) × 1920	
4	Display mode	Normally Black, Transmissive	
5	Pixel pitch	0.1128(W) × 0.1128(H) mm	
6	Active area	135.36(W) × 216.576(H) mm	
7	Module Size	143(W) × 228.6(H) × 2.6(D) mm	Note1
8	Surface treatment	AG	
9	Color arrangement	RGB-stripe	
10	Interface	40MIPI	
11	View direction(Gray Inversion)	Free	
12	Panel power consumption	0.5W(Typ.)	Note 2
13	Weight	TBD	
14	IC	NT51021	
15	inversion	column	

Note 1: Refer to Mechanical Drawing.

Note 2: Including T-con Board power consumption



2. Pin Assignment

A 40pin connector is used for the module electronics interface. The recommended model is FH33J-40S-0.5SH(10) manufactured by Hirose.

PIN NO	SYMBOL	Description
1	NC	OPEN
2-3	VDDIN	Power SUPPLY 3.3V
4	GND	Ground
5	RESET	Global reset signal
6	NC	OPEN
7	GND	Ground
8	MIPI_TDNO	MIPI data input.
9	MIPI_TDPO	MIPI data input.
10	GND	Ground
11	MIPI_TDN1	MIPI data input.
12	MIPI_TDP1	MIPI data input.
13	GND	Ground
14	MIPI_TCN	MIPI clock input.
15	MIPI_TCP	MIPI clock input.
16	GND	Ground
17	MIPI_TDN2	MIPI data input.
18	MIPI_TDP2	MIPI data input.
19	GND	Ground
20	MIPI_TDN3	MIPI data input.
21	MIPI_TDP3	MIPI data input.
22	GND	Ground
23-24	NC	OPEN
25	GND	Ground
26	NC	OPEN
27	CABC	PWM control signal for LED driver
28-29	NC	OPEN
30	GND	Ground
31-32	LEDK	LED Cathode
33-34	NC	OPEN
35	AVEE	OPEN
36-37	NC	OPEN
38	AVDD	OPEN
39-40	LEDA	LED Anode



宇华国际科技有限公司

YuHua INT,L Technology Co., LIMITED

I: input, O: output, P: Power

Note1: LED_PWM is used to adjust backlight brightness.

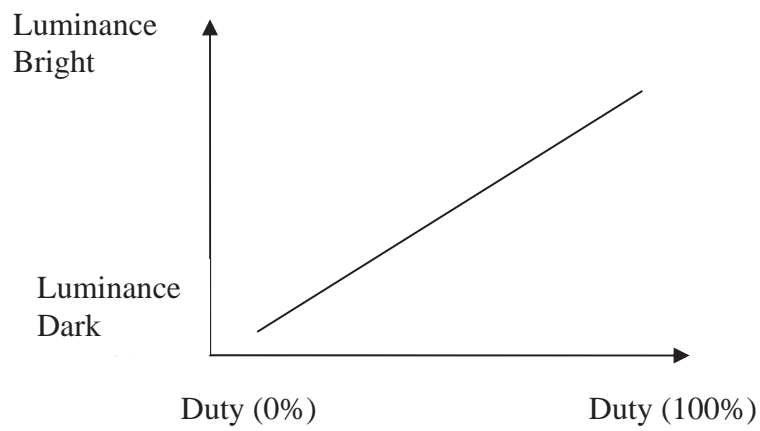



3. Operation Specifications

3.1. Absolute Maximum Ratings

(Note 1)

Item	Symbol	Values		Unit	Remark
		Min.	Max.		
Power voltage	V _{CCS}	3.0	3.6	V	
	AV _{DD}	9	9.4	V	
	V _{GH}	20.7	21.3	V	
	V _{GL}	-7.3	-6.7	V	
Operation Temperature	T _{OP}	-20	60	°C	
Storage Temperature	T _{ST}	-25	70	°C	

Note 1: The absolute maximum rating values of this product are not allowed to be exceeded at any times. Should a module be used with any of the absolute maximum ratings exceeded, the characteristics of the module may not be recovered, or in an extreme case, the module may be permanently destroyed.

3.1.1. Current Consumption

Item	Symbol	Values			Unit	Remark
		Min.	Typ.	Max.		
Current for Driver	I _{GH}	-	TBD	/	uA	V _{GH} =21V
	I _{GL}	-	TBD	/	uA	V _{GL} = -7V
	I _{V_{CCS}}	-	TBD	/	mA	V _{CCS} =3.3V
	I _{AV_{DD}}	-	TBD	/	mA	AV _{DD} =9.2V



3.2. Typical Operation Conditions

(Note 1)

Item	Symbol	Values			Unit	Remark
		Min.	Typ.	Max.		
Power voltage	VCCS	3.0	3.3	3.6	V	Note 2
	AVDD	9.0	9.2	9.4	V	
	V _{GH}	20.7	21	21.3	V	
	V _{GL}	-7.3	-7	-6.7	V	
Input logic high voltage	V _{IH}	0.7 VDD	-	VCCS	V	
Input logic low voltage	V _{IL}	0	-	0.3 DV	V	

Note 1: Be sure to apply VCCS and V_{GL} to the LCD first, and then apply V_{GH}

Note 2: VCCS setting should match the signals output voltage (refer to Note 3) of customer's system board.



3.3. Power Sequence

a. Power on:

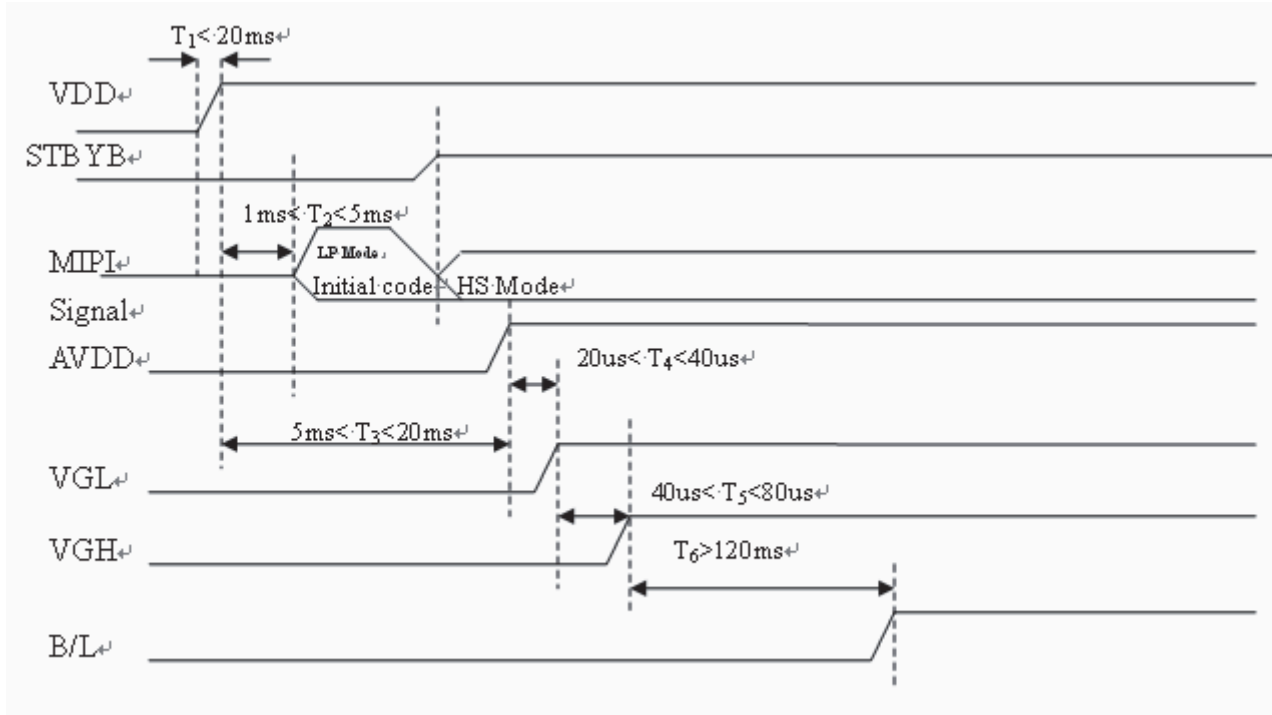

b. Power off:

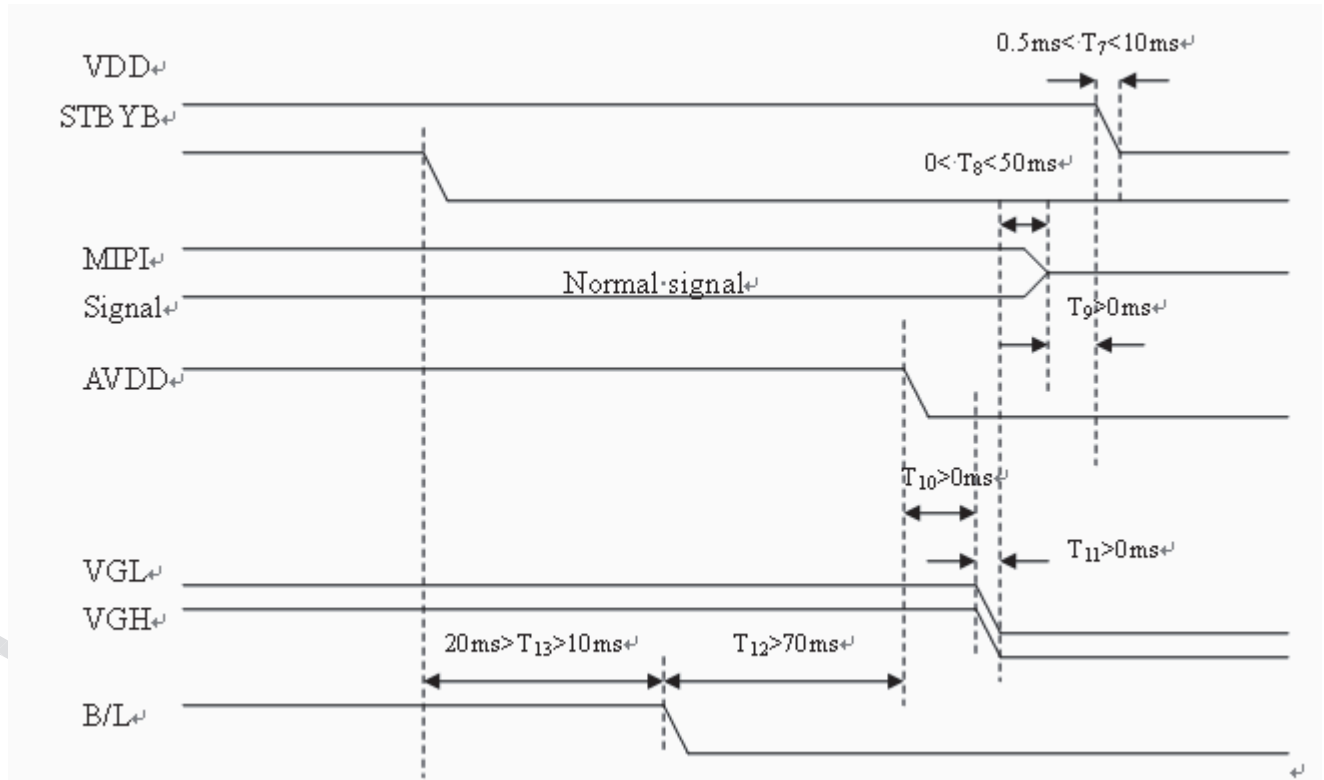



3.4. Timing Characteristics

3.4.1. AC Electrical Characteristics

Parameter	Symbol	Min	Typ	Max	Units
15%-85% rise time and fall time	T_{RLP} / T_{FLP}	-	-	25	ns
Pulse width of the LP exclusive-OR clock	$T_{LP-PULSE-TX}$	50	-	-	ns
Period of the LP exclusive-OR clock	$T_{LP-PER-TX}$	100	-	-	ns

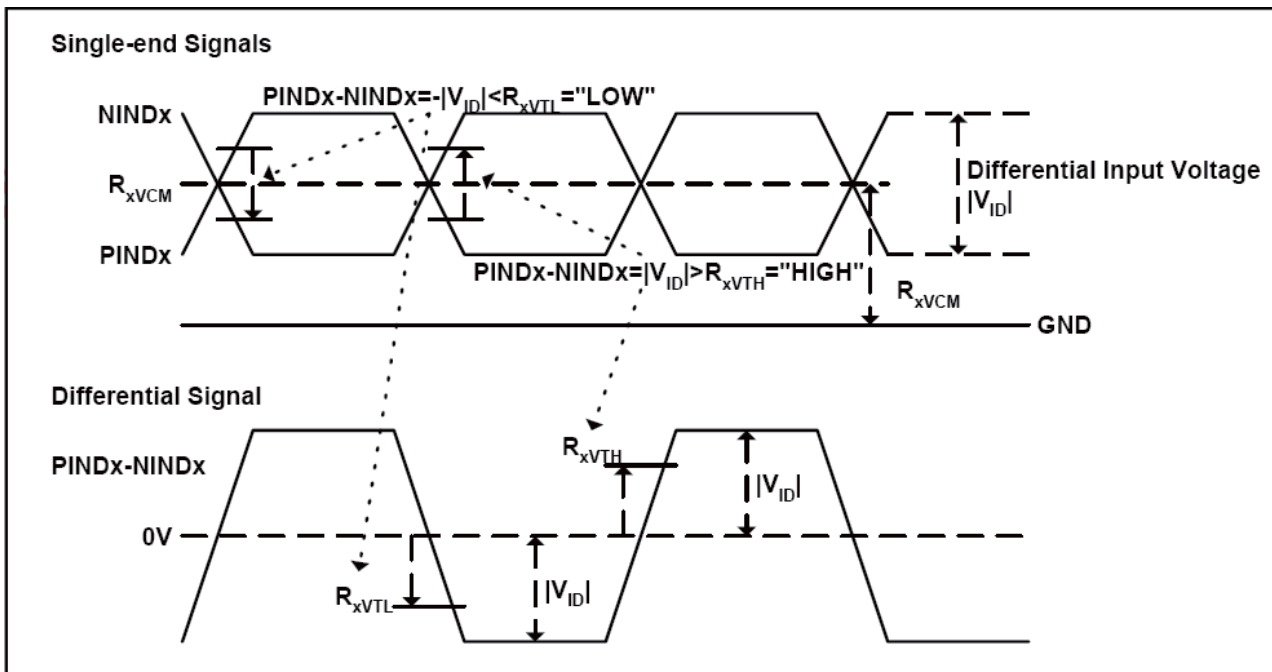
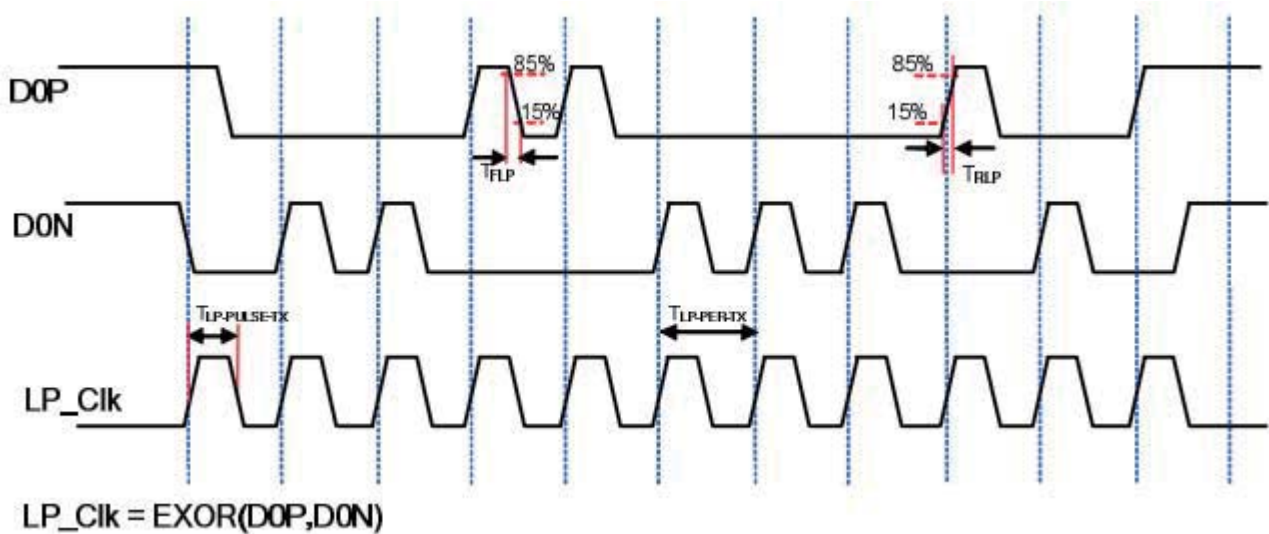

3.4.2. HS Transmission

Parameter	Symbol	Min	Typ	Max	Units
UI instantaneous	UI_{INST}	1.0	-	12.5	ns
Data to Clock Setup Time	T_{SETUP}	0.3	-	-	UI_{INST}
Data to Clock Hold Time	T_{HOLD}	0.3	-	-	UI_{INST}

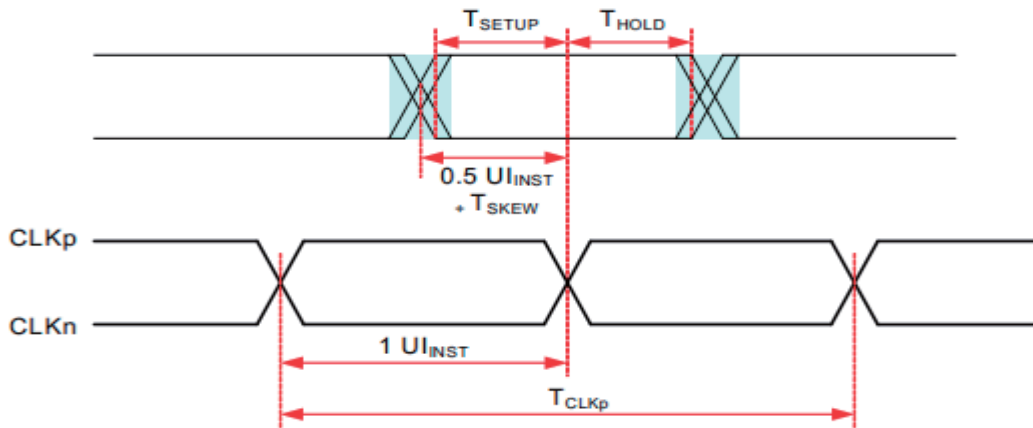

3.4.3. DC Electrical Characteristics

Parameter	Symbol	Min.	Typ.	Max.	Unit	Condition
MIPI digital operation current	I_{VCCIF}	-	-	24	mA	$V_{CC}=V_{CC_IF}=1.6V$, Data Rate=500Mbps, Input pattern: 55h→AAh→55h→AAh
MIPI digital stand-by current	$I_{VCCIFST}$	-	200	-	uA	V_{CC_IF} input current. All input signal are stopped.
MIPI Characteristics for High Speed Receiver						
Single-ended input low voltage	V_{ILHS}	-40	-	-	mV	
Single-ended input high voltage	V_{IHHS}	-	-	460	mV	
Common-mode voltage	V_{CMRXDC}	155	-	330	mV	
Differential input impedance	Z_{ID}	80	100	125	ohm	
Differential input high threshold	V_{IDTH}	-	-	70	mV	
Differential input low threshold	V_{IDTL}	70	-	-	mV	
MIPI Characteristics for Low Power Mode						
Pad signal voltage range	V_I	-50	-	1350	mV	
Ground shift	V_{GNDSH}	-50	-	50	mV	
Input low level	V_{IL}	-150	-	150	mV	
Input high level	V_{IH}	1.1	1.2	1.3	V	

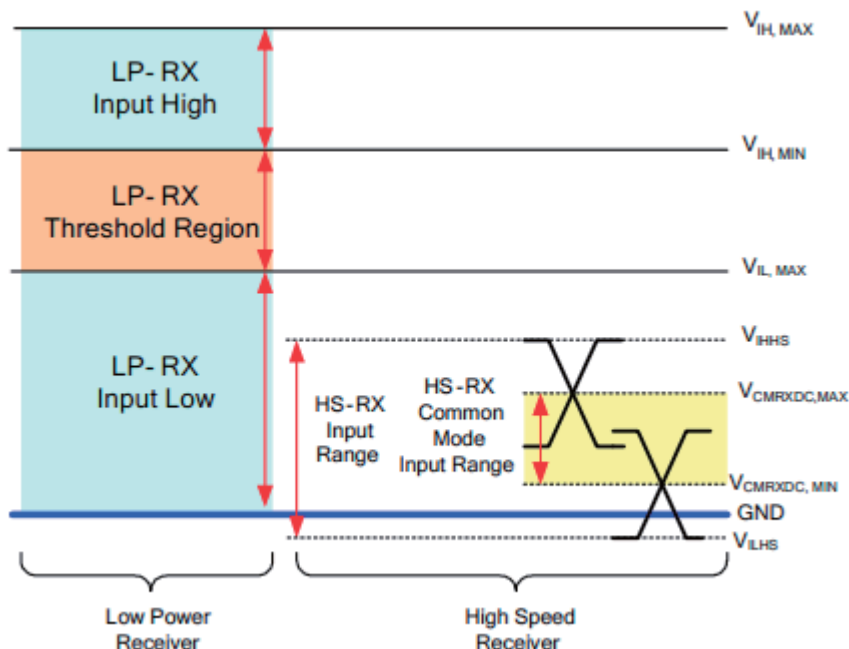



3.4.4. Timing Table

Parameter	Symbol	Min.	Typ.	Max.	Unit
MIPI data frequency	F_{DATA}	955	999	1000	Mbps
Horizontal display area	T_{HD}	1200			pixel
Hsync period time	T_H	1275	1341	1342	pixel
Hsync pulse width	T_{HPW}	1	1	1	pixel
Hsync back porch	T_{HBP}	32	60	60	pixel
Hsync front porch	T_{HFP}	42	80	81	pixel
Vertical display area	T_{VD}	1920			H
Vsync period time	T_V	1981	1981	1982	H
Vsync pulse width	T_{VPW}	1	1	1	H
Vsync back porch	T_{VBP}	25			H
Vsync front porch	T_{VFP}	35	35	36	H

3.4.5. Data Input Format For Mipi

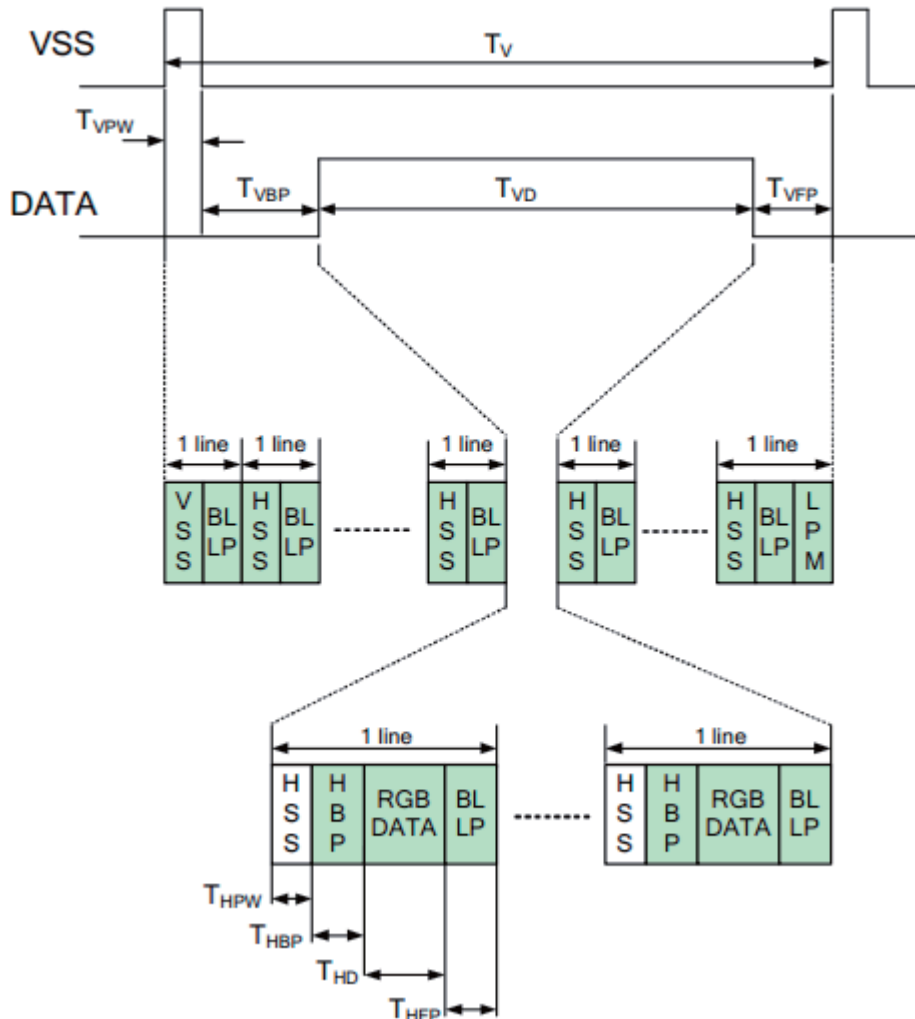



4. Optical Specifications

Item	Symbol	Condition	Values			Unit	Remark
			Min.	Typ.	Max.		
Viewing angle (CR≥ 10)	θL	Φ=180°(9 o'clock)	75	85	-	degree	Note 1
	θR	Φ=0°(3 o'clock)	75	85	-		
	θT	Φ=90°(12 o'clock)	75	85	-		
	θB	Φ=270°(6 o'clock)	75	85	-		
Response time	Tr+Tf		-	25	30	msec	Note 3
Contrast ratio	CR		800	1000	-	-	Note 4 Note 7
Color chromaticity	WX		0.25	0.30	0.35	-	Note 2 Note 5
	WY		0.27	0.32	0.37	-	Note 6 Note 7
Transmittance w/o APCF	T%		3.4	4.01	-	%	Note2 Note 7

Test Conditions:

1. VCCS=3.3V, the ambient temperature is 25°C.
2. The test systems refer to Note 2.



宇华国际科技有限公司

YuHua INT,L Technology Co., LIMITED

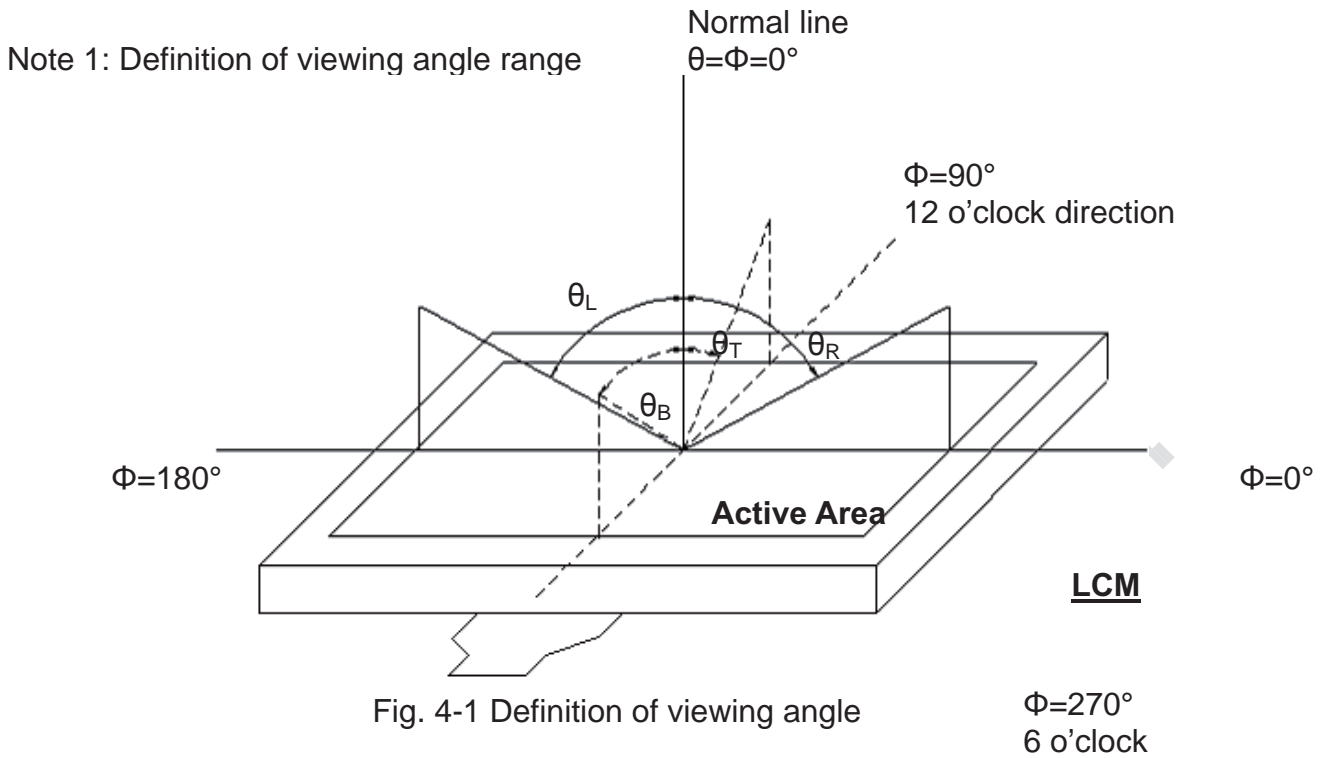

Note 2: Definition of optical measurement system.

The optical characteristics should be measured in dark room. After 30 minutes operation, the optical properties are measured at the center point of the LCD screen. (Viewing angle is measured by ELDIM-EZ contrast/Height :1.2mm, Response time is measured by Photo detector TOPCON BM-7, other items are measured by BM-5A/ Field of view: 1° /Height: 500mm.)

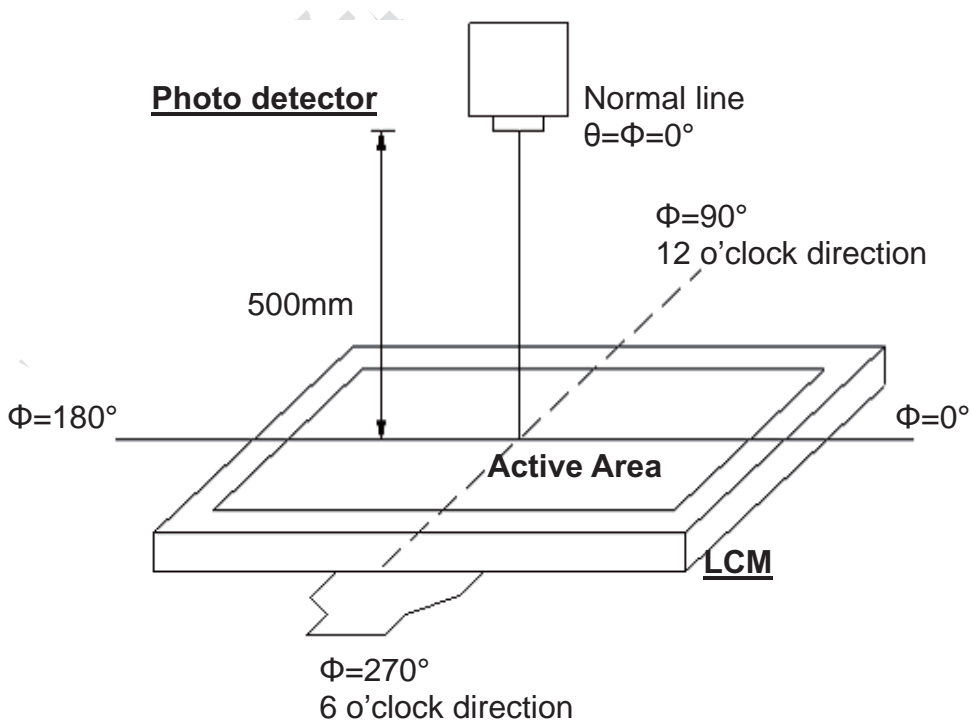

Fig. 4-2 Optical measurement system setup



Note 3: Definition of Response time

The response time is defined as the LCD optical switching time interval between "White" state and "Black" state. Rise time (T_r) is the time between photo detector output intensity changed from 10% to 90%. And fall time (T_f) is the time between photo detector output intensity changed from 90% to 10%.

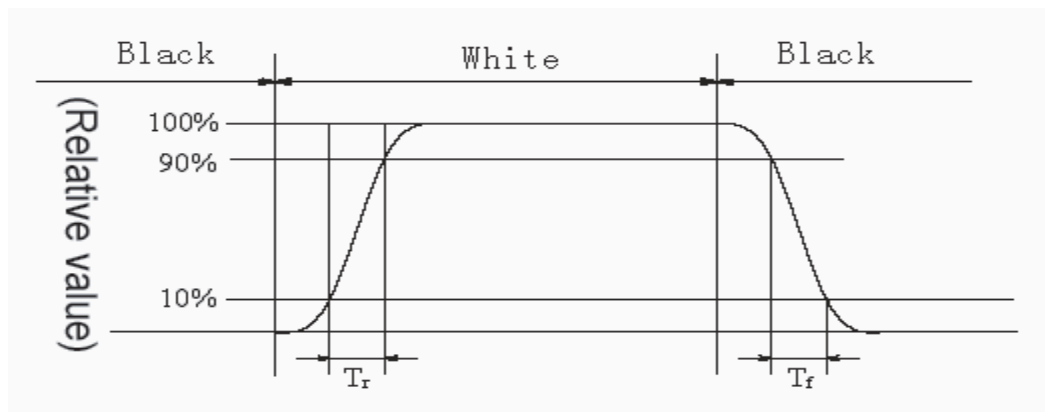

Fig. 4-3 Definition of response time

Note 4: Definition of contrast ratio

$$\text{Contrast ratio (CR)} = \frac{\text{Luminance when LCD on the "White" state}}{\text{Luminance when LCD on the "Black" state}}$$

Note 5: Definition of color chromaticity (CIE1931)

Color coordinates measured at center point of LCD.

Note 6: All input terminals LCD panel must be ground while measuring the center area of the panel.

Note 7: Base on backlight structure of LCM is Diffuse+BEF+BEF+ Diffuse and the INX LED BLU Spectrum as below.

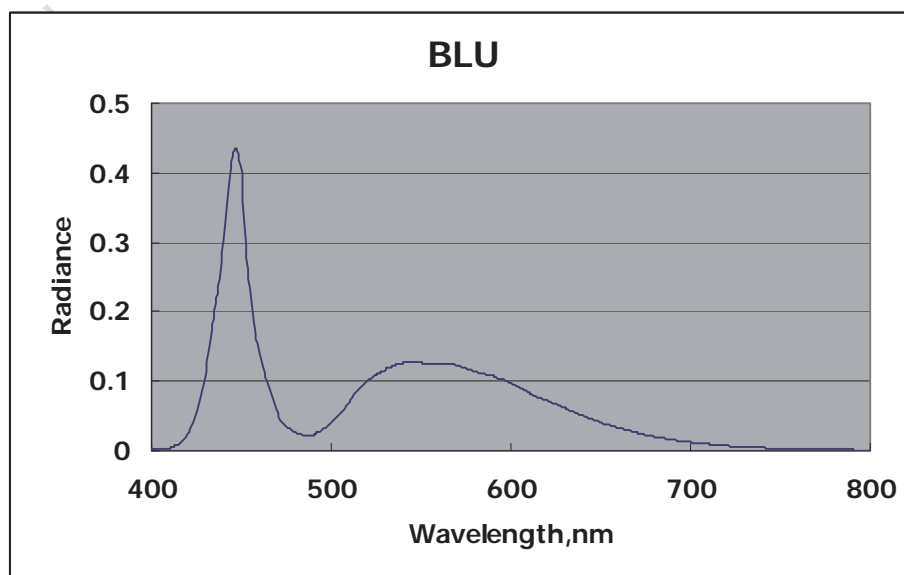



6. General Precautions

6.1. Safety

Liquid crystal is poisonous. Do not put it in your mouth. If liquid crystal touches your skin or clothes, wash it off immediately by using soap and water.

6.2. Handling

1. The LCD panel is plate glass. Do not subject the panel to mechanical shock or to excessive force on its surface.
2. The polarizer attached to the display is easily damaged. Please handle it carefully to avoid scratch or other damages.
3. To avoid contamination on the display surface, do not touch the module surface with bare hands.
4. Keep a space so that the LCD panels do not touch other components.
5. Put cover board such as acrylic board on the surface of LCD panel to protect panel from damages.
6. Transparent electrodes may be disconnected if you use the LCD panel under environmental conditions where the condensation of dew occurs.
7. Do not leave module in direct sunlight to avoid malfunction of the ICs.

6.3. Static Electricity

1. Be sure to ground module before turning on power or operating module.
2. Do not apply voltage which exceeds the absolute maximum rating value.

6.4. Storage

1. Store the module in a dark room where must keep at $25\pm 10^{\circ}\text{C}$ and 65%RH or less.
2. Do not store the module in surroundings containing organic solvent or corrosive
3. Store the module in an anti-electrostatic container or bag.

6.5. Cleaning

1. Do not wipe the polarizer with dry cloth. It might cause scratch.
2. Only use a soft sloth with IPA to wipe the polarizer, other chemicals might permanent damage to the polarizer.

