



**SPECIFICATION  
FOR  
LCD MODULE**

**Customer** : \_\_\_\_\_  
**Product Model:** YH700AT9309  
**Sample code:** \_\_\_\_\_

Designed by	Checked by	Approved by

**Final Approval by Customer**

<input type="checkbox"/> <b>LCM Machinery OK</b> Checked By _____  <input type="checkbox"/> <b>LCM Display OK</b> Checked By _____	<input type="checkbox"/> <b>LCM OK</b>  <input type="checkbox"/> <b>NG , Problem survey:</b>  Approved By _____
--	---

※The specification of "TBD" should refer to the measured value of sample . If there is difference between the design specification and measured value, we naturally shall negotiate and agree to solution with customer.

## Record of Revision

Version	Revise Date	Page	Content
V01	2021/ 09/ 25		Initial release.

# Contents

1. General Specifications .....	1
2. Pin Assignment .....	2
3. Operation Specifications .....	4
3.1. Absolute Maximum Ratings .....	4
3.2. Typical Operation Conditions .....	5
3.3. Power Sequence .....	6
3.4. Timing Characteristics .....	7
3.4.1. Timing Conditions .....	7
3.4.2. Timing Diagram .....	7
4. Optical Specifications .....	9
5. Reliability Test Items .....	12
6. General Precautions .....	13
6.1. Safety .....	13
6.2. Handling .....	13
6.3. Static Electricity .....	13
6.4. Storage .....	13
6.5. Cleaning .....	13
7. Mechanical Drawing .....	14
8. Package Drawing .....	15

# 1. General Specifications

No.	Item	Specification	Remark
1	LCD size	7.0 inch(Diagonal)	
2	Driver element	a-Si TFT active matrix	
3	Resolution	800X3(RGB)X480	
4	Display mode	Normally Black	
5	Dot pitch	0.0635(W)X0.1905(H) mm	
6	Active area	152.4 (W)X91.44 (H) mm	
7	Module size	165(W)X104.09(H)X5.3 (D) mm	Note 1
8	Surface treatment	Anti-Glare	
9	Color arrangement	RGB-stripe	
10	Interface	Digital (TTL)	
11	Backlight power consumption	1.5W (Typ.)	Note 2
12	Panel power consumption	0.66 W (Typ.)	Note 3
13	Weight	T.B.D.	

Note 1: Refer to Mechanical Drawing.

Note 2: Including LED Driver power consumption.

Note 3: Including T-con power consumption.

## 2. Pin Assignment

Pin No.	Symbol	Description	Remark
1	GND	Power Ground	
2	GND	Power Ground	
3	NC	Not Connect	
4	Vcc	Power Supply for Digital Circuit	
5	Vcc	Power Supply for Digital Circuit	
6	Vcc	Power Supply for Digital Circuit	
7	Vcc	Power Supply for Digital Circuit	
8	NC	Not Connect	
9	DE	Data Enable	
10	GND	Power Ground	
11	GND	Power Ground	
12	GND	Power Ground	
13	B5	Blue Data 5 (MSB)	
14	B4	Blue Data 4	
15	B3	Blue Data 3	
16	GND	Power Ground	
17	B2	Blue Data 2	
18	B1	Blue Data 1	
19	B0	Blue Data 0 (LSB)	
20	GND	Power Ground	
21	G5	Green Data 5 (MSB)	
22	G4	Green Data 4	
23	G3	Green Data 3	
24	GND	Power Ground	
25	G2	Green Data 2	
26	G1	Green Data 1	
27	G0	Green Data 0 (LSB)	
28	GND	Power Ground	
29	R5	Red Data 5 (MSB)	
30	R4	Red Data 4	
31	R3	Red Data 3	
32	GND	Power Ground	
33	R2	Red Data 2	
34	R1	Red Data 1	
35	R0	Red Data 0 (LSB)	
36	GND	Power Ground	
37	GND	Power Ground	
38	DCLK	Clock Signals ; Latch Data at the Falling Edge	
39	GND	Power Ground	
40	GND	Power Ground	

Note: User's connector part number is **MT-FP430N-2FR** manufactured by UJU or equivalent.

### Backlight Driving Part

Pin No.	Symbol	Description
1	VLED+	Red, LED_ Anode
2	VLED-	White, LED_ Cathode

Note: The backlight interface connector is a model **SM02B-BHSS-1-TB** manufactured by JST or equivalent. The matching connector part number is **BHSR-20VS-1** manufactured by JST or equivalent.

### BLOCK DIAGRAM

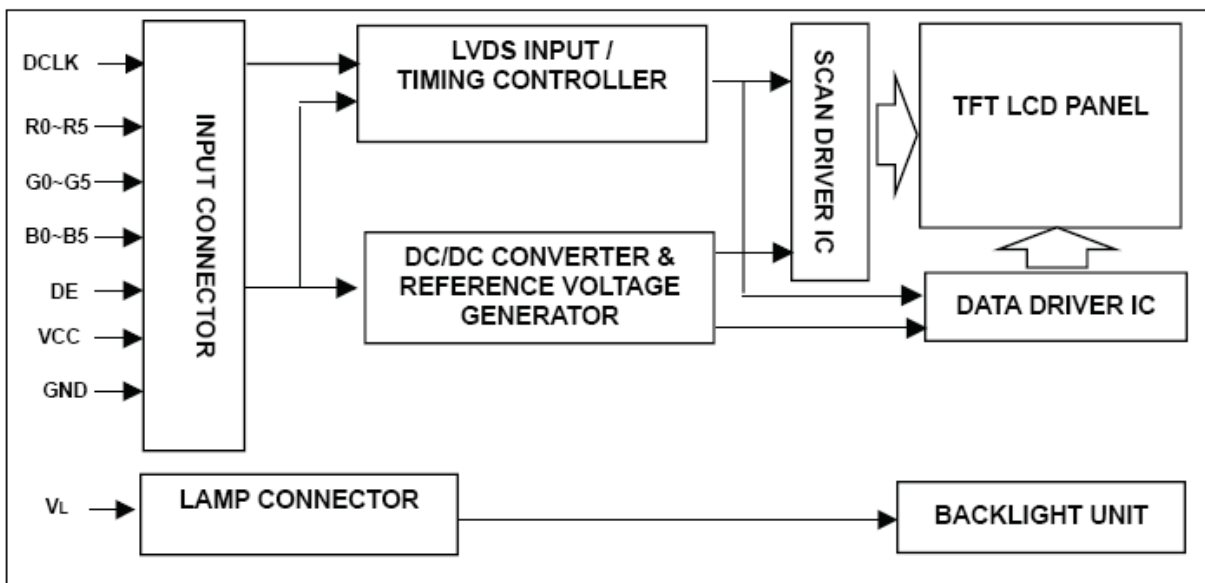

Scanning direction refer to the figure below.

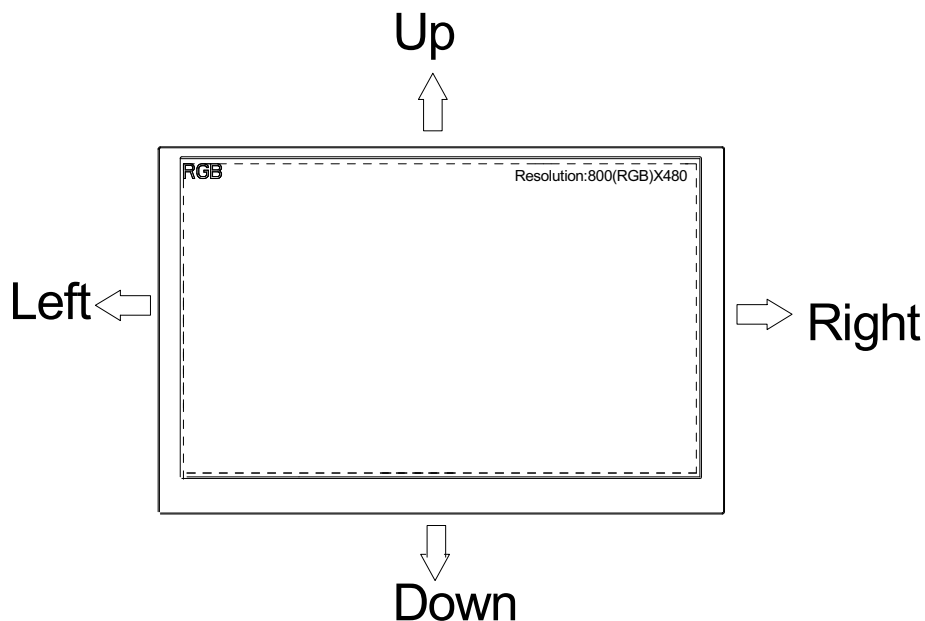

## 3. Operation Specifications

### 3.1. Absolute Maximum Ratings

Item	Symbol	Values		Unit	Remark
		Min.	Max.		
Power voltage	$V_{CC}$	-0.3	6.0	V	
Input signal voltage	$V_I$	-0.3	6.3	V	
Operation Temperature	$T_{OP}$	-20	70	°C	
Storage Temperature	$T_{ST}$	-30	80	°C	

Note: The absolute maximum rating values of this product are not allowed to be exceeded at any times. A module should be used with any of the absolute maximum ratings exceeded, the characteristics of the module may not be recovered, or in an extreme condition, the module may be permanently destroyed.

## 3.2. Typical Operation Conditions

Item	Symbol	Values			Unit	Remark
		Min.	Typ.	Max.		
Power voltage	$V_{CC}$	3.1	3.3	3.5	V	Note 1
Current consumption	$I_{CC}$	-	200	260	mA	
	$I_F$	-	160	-	mA	Note 2
Input logic high voltage	$V_{IH}$	$0.7V_{CC}$	-	V	V	Note 3
Input logic low voltage	$V_{IL}$	0	-	0.3V	V	
LED life time	-	20,000	-	-	Hr	Note 4

Note1:  $V_{CC}$  setting should match the signals output voltage (refer to Note 4) of customer's system board.

Note 2: LED driving current.

Note 3 : DCLK,DE, HS, VS, R0~ R5,,G0~ G5,B0~ B5.

Note 4: The "LED life time" is defined as the module brightness decrease to 50% original brightness at  $T_a=25$  and  $I_{LED}=160$  mA . The LED lifetime could be decreased if operating  $I_{LED}$  is larger than 160 mA .

### 3.3. Power Sequence

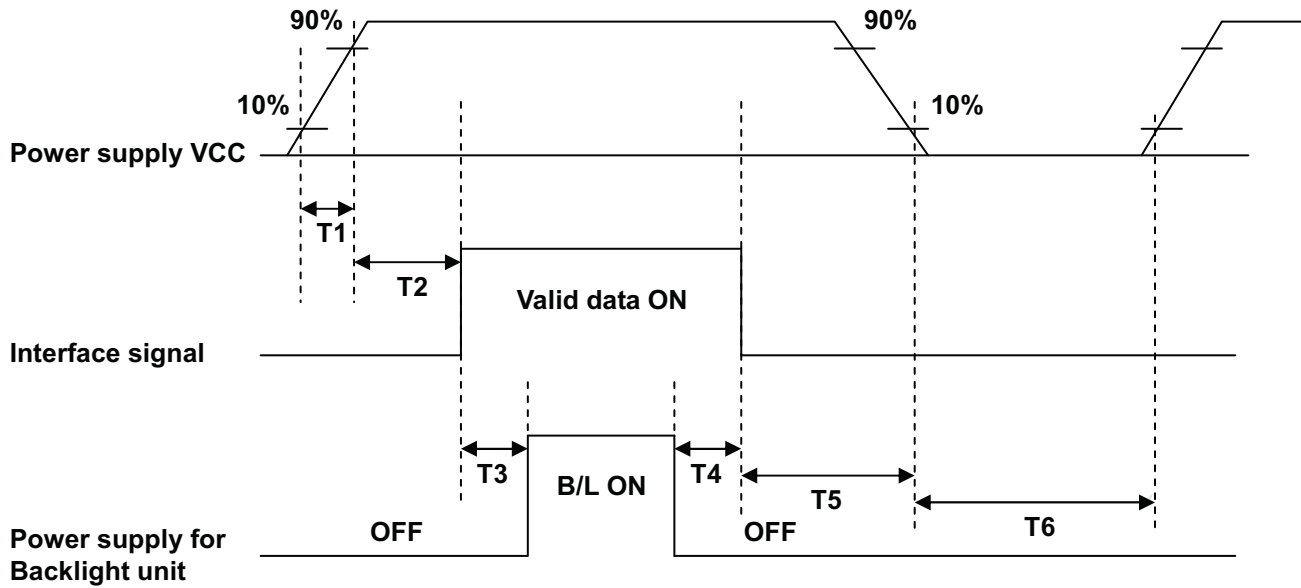

Parameter	SPEC.			Unit
	Min.	Typ.	Max.	
T1	1		2	ms
T2	0	60		ms
T3	200			ms
T4	200			ms
T5	1			ms
T6	1000			ms

## 3.4. Timing Characteristics

### 3.4.1. Timing Conditions

Item	Symbol	Min	Typ	Max	Unit	Remark
Clock frequency	$F_{CLK}$	27.027	29.988	40.0	MHz	
Vertical display area	$T_{VD}$	480			H	
Vertical period area	$T_V$	525	525	530	H	
Vertical blanking area	$T_{VB}$	45	45	50	H	Note1
Vertical pulse width	$T_{VPW}$	3			H	
Vertical back porch	$T_{VBP}$	20			H	
Vertical front porch	$T_{VFP}$	25	25	30	H	
Horizontal display area	$T_{HD}$	800			dclk	
Horizontal period area	$T_H$	858	952	1258	dclk	
Horizontal blanking area	$T_{HB}$	58	152	458	dclk	Note2
Horizontal pulse width	$T_{HPW}$	3			dclk	
Horizontal back porch	$T_{HBP}$	48			dclk	
Horizontal front porch	$T_{HFP}$	10	104	410	dclk	
HS setup time	$T_{HSU}$	6	-	-	ns	
HS hold time	$T_{HHD}$	6	-	-	ns	
VS setup time	$T_{VSU}$	6	-	-	ns	
VS hold time	$T_{VHD}$	6	-	-	ns	
Data setup time	$T_{DSU}$	6	-	-	ns	
Data hold time	$T_{DHU}$	6	-	-	ns	
DE setup time	$T_{ESU}$	6	-	-	ns	

Note1:  $T_{VB} = T_V - T_{VD}$

Note2:  $T_{HB} = T_H - T_{HD}$

### 3.4.2. Timing Diagram

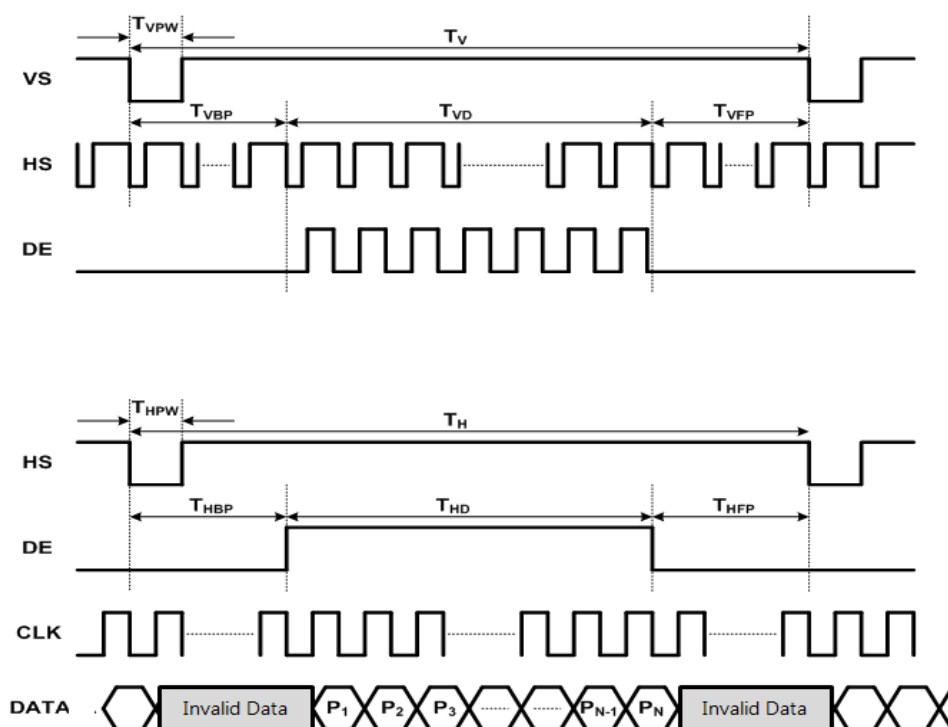

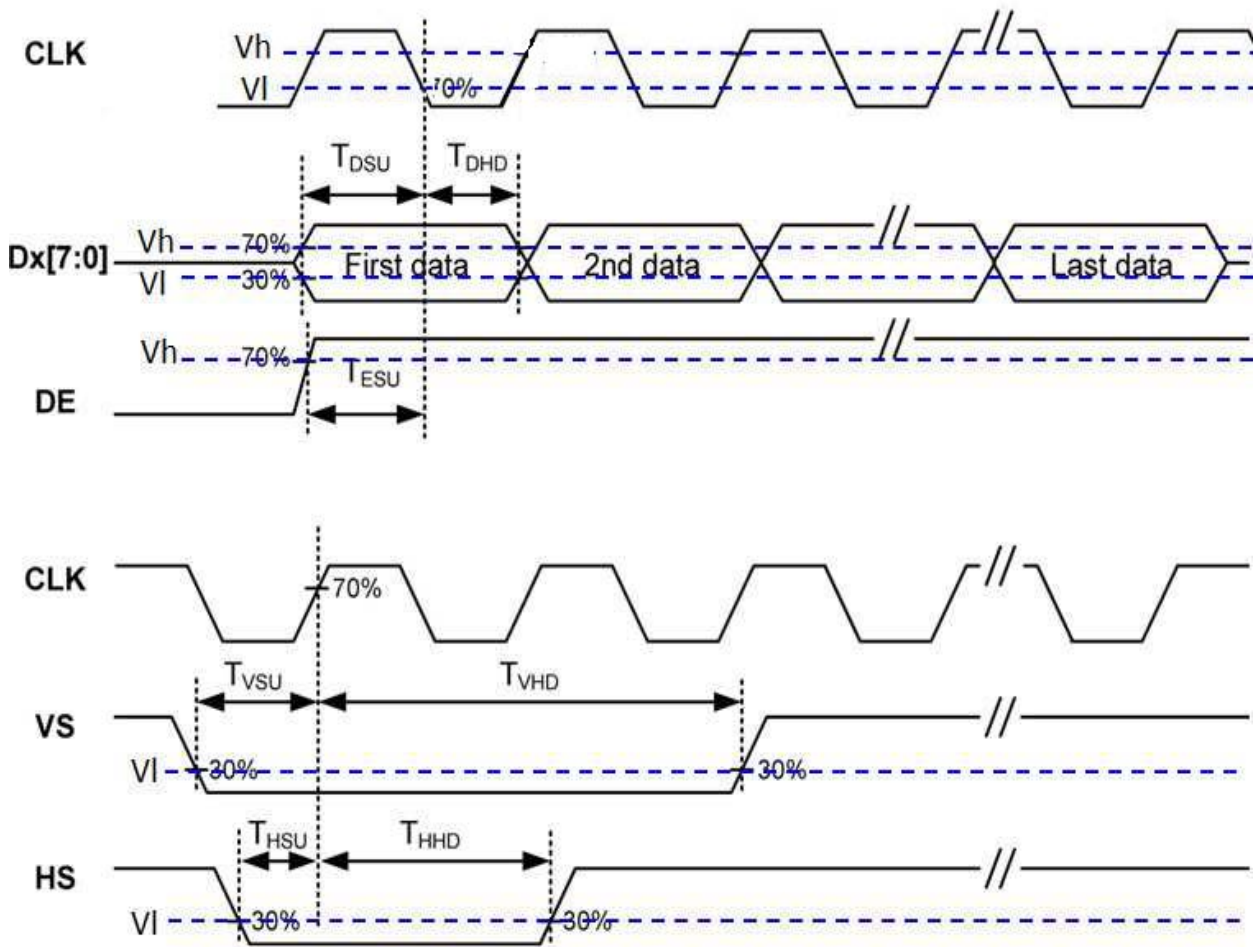

Note : Latch data at CLK falling edge.

## 4. Optical Specifications

Item	Symbol	Condition	Values			Unit	Remark
			Min.	Typ.	Max.		
Viewing angle (CR ≥ 10)	$\theta_L$	$\Phi=180^\circ$ (9 o'clock)	70	80	-	degree	Note 1
	$\theta_R$	$\Phi=0^\circ$ (3 o'clock)	70	80	-		
	$\theta_T$	$\Phi=90^\circ$ (12 o'clock)	70	80	-		
	$\theta_B$	$\Phi=270^\circ$ (6 o'clock)	70	80	-		
Response time	$T_{ON}$	Normal $\theta=\Phi=0^\circ$	-	11	-	msec	Note 3
	$T_{OFF}$		-	9	-	msec	Note 3
Contrast ratio	CR		800	1000	-	-	Note 4
Color chromaticity	$W_X$		0.270	0.0290	0.350		Note 2 Note 5
	$W_Y$		0.280	0.0300	0.360		Note 6
Luminance	L		-	350	-	cd/m <sup>2</sup>	Note 6
Luminance uniformity	$Y_U$		70	75	-	%	Note 7

Note 1: Definition of viewing angle range

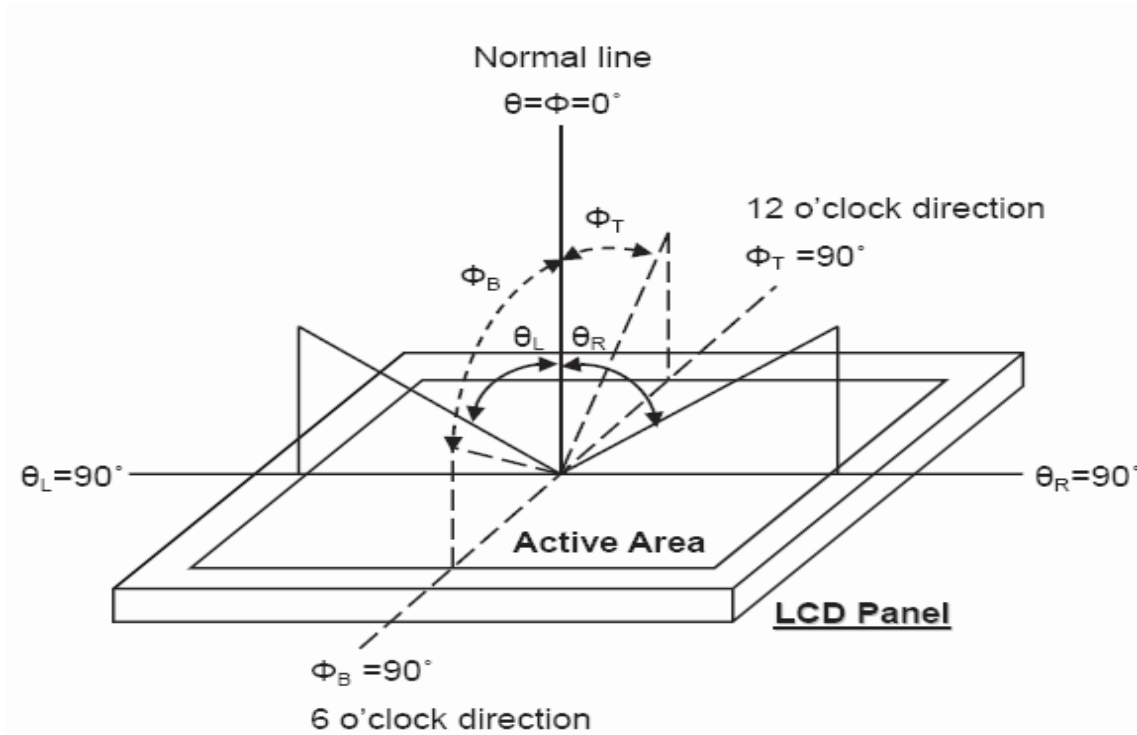

Fig. 7-1 Definition of viewing angle

Note 2: Test equipment setup:

After stabilizing and leaving the panel alone at a driven temperature for 10 minutes, the measurement should be executed. Measurement should be executed in a stable, windless, and dark room. Optical specifications are measured by Topcon BM-7 luminance meter 1.0° field of view at a distance of 50cm and normal direction.

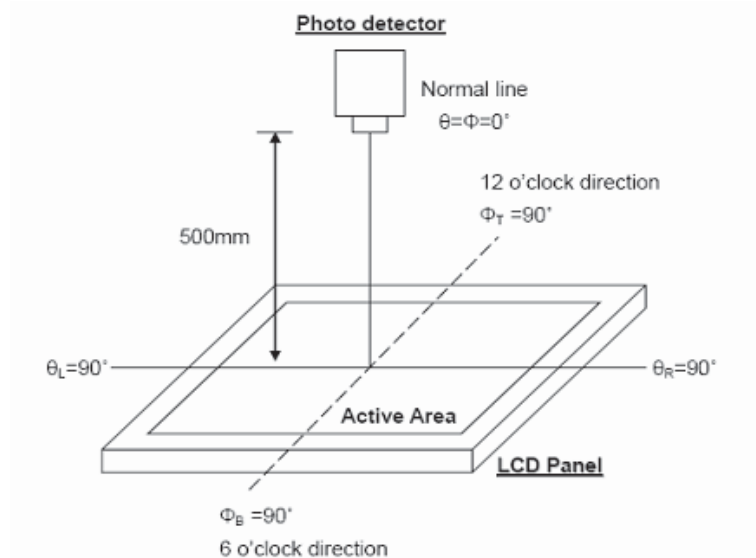
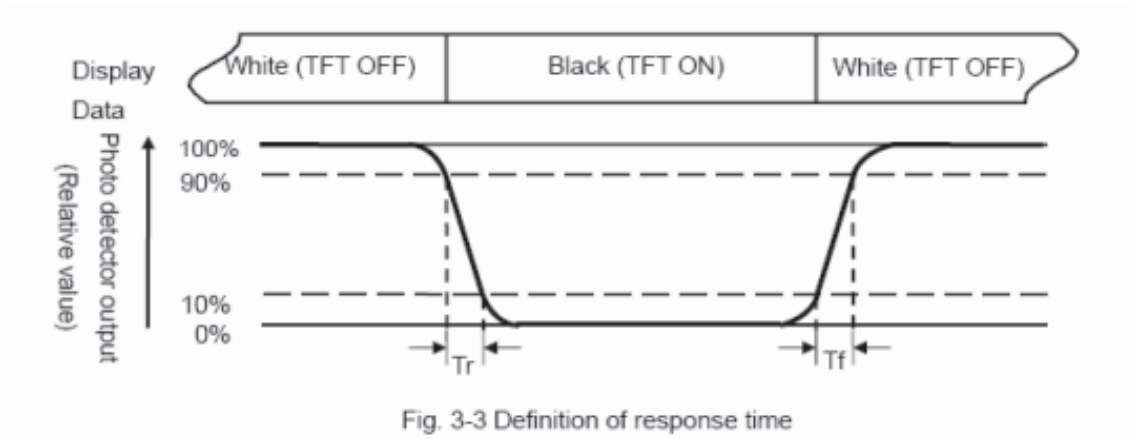

Fig.7-2 Optical measurement system setup

Note 3: Definition of Response time:

The response time is defined as the LCD optical switching time interval between “White state and “Black” state. Rise time,  $T_r$ , is the time between photo detector output intensity changed from 90% to 10% . And fall time,  $T_f$ , is the time between photo detector output Intensity changed from 10% to 90% .



Note 4: Definition of contrast ratio:

The contrast ratio is defined as the following expression.

$$\text{Contrast ratio (CR)} = \frac{\text{Luminance measured when LCD on the "White" state}}{\text{Luminance measured when LCD on the "Black" state}}$$

Note 5: White  $V_i = V_{i50} \pm 1.5V$

Black  $V_i = V_{i50} \pm 2.0V$

“±” means that the analog input signal swings in phase with VCOM signal.

“±” means that the analog input signal swings out of phase with VCOM signal.

The 100% transmission is defined as the transmission of LCD panel when all the input terminals of module are electrically opened.

Note 6: Definition of color chromaticity (CIE 1931)

Color coordinates measured at the center point of LCD

Note 7: Measured at the center area of the panel when all the input terminals of LCD panel are electrically opened.

$$\text{Note 8 : Uniformity (U)} = \frac{\text{Brightness (min)}}{\text{Brightness (max)}} \times 100\%$$



## 6. General Precautions

### 6.1. Safety

Liquid crystal is poisonous. Do not put it in your mouth. If liquid crystal touches your skin or clothes, wash it off immediately by using soap and water.

### 6.2. Handling

1. The LCD panel is plate glass. Do not subject the panel to mechanical shock or to excessive force on its surface.
2. The polarizer attached to the display is easily damaged. Please handle it carefully to avoid scratch or other damages.
3. To avoid contamination on the display surface, do not touch the module surface with bare hands.
4. Keep a space so that the LCD panels do not touch other components.
5. Put cover board such as acrylic board on the surface of LCD panel to protect panel from damages.
6. Transparent electrodes may be disconnected if you use the LCD panel under environmental conditions where the condensation of dew occurs.
7. Do not leave module in direct sunlight to avoid malfunction of the ICs.

### 6.3. Static Electricity

1. Be sure to ground module before turning on power or operating module.
2. Do not apply voltage which exceeds the absolute maximum rating value.

### 6.4. Storage

1. Store the module in a dark room where must keep at  $25\pm 10^{\circ}\text{C}$  and 65%RH or less.
2. Do not store the module in surroundings containing organic solvent or corrosive gas.
3. Store the module in an anti-electrostatic container or bag.

### 6.5. Cleaning

1. Do not wipe the polarizer with dry cloth. It might cause scratch.
2. Only use a soft sloth with IPA to wipe the polarizer, other chemicals might permanent damage to the polarizer.

# 7. Mechanical Drawing

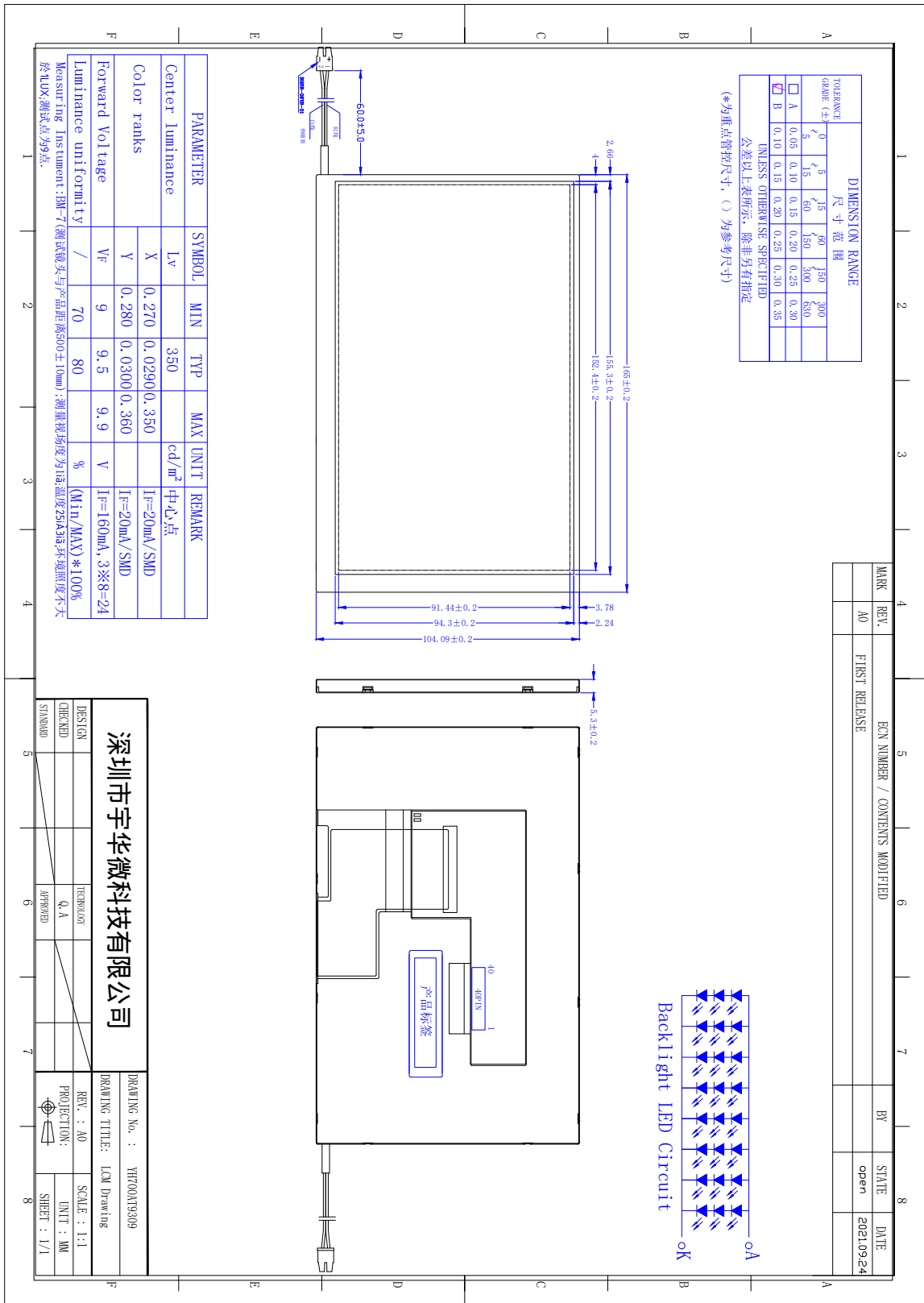

## 8. Package Drawing

T.B.D.